



Chipsmall Limited consists of a professional team with an average of over 10 year of expertise in the distribution of electronic components. Based in Hongkong, we have already established firm and mutual-benefit business relationships with customers from,Europe,America and south Asia,supplying obsolete and hard-to-find components to meet their specific needs.

With the principle of “Quality Parts,Customers Priority,Honest Operation,and Considerate Service”,our business mainly focus on the distribution of electronic components. Line cards we deal with include Microchip,ALPS,ROHM,Xilinx,Pulse,ON,Everlight and Freescale. Main products comprise IC,Modules,Potentiometer,IC Socket,Relay,Connector.Our parts cover such applications as commercial,industrial, and automotives areas.

We are looking forward to setting up business relationship with you and hope to provide you with the best service and solution. Let us make a better world for our industry!



Contact us

Tel: +86-755-8981 8866 Fax: +86-755-8427 6832

Email & Skype: info@chipsmall.com Web: www.chipsmall.com

Address: A1208, Overseas Decoration Building, #122 Zhenhua RD., Futian, Shenzhen, China



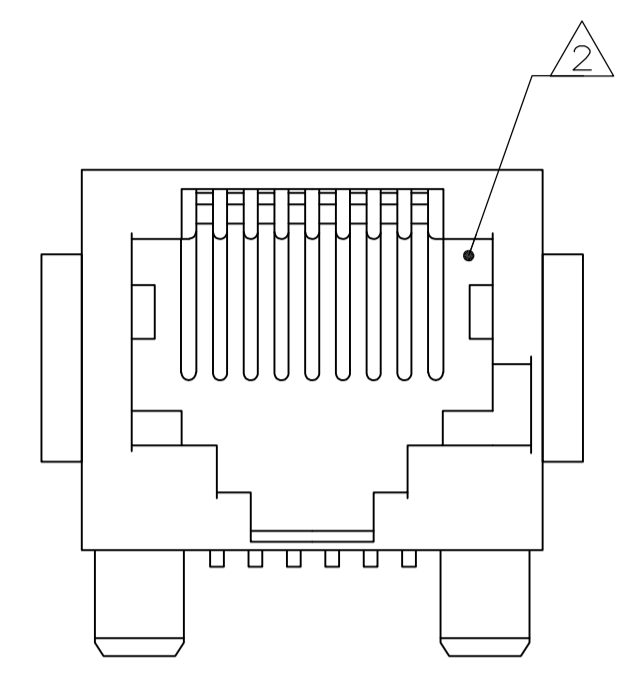
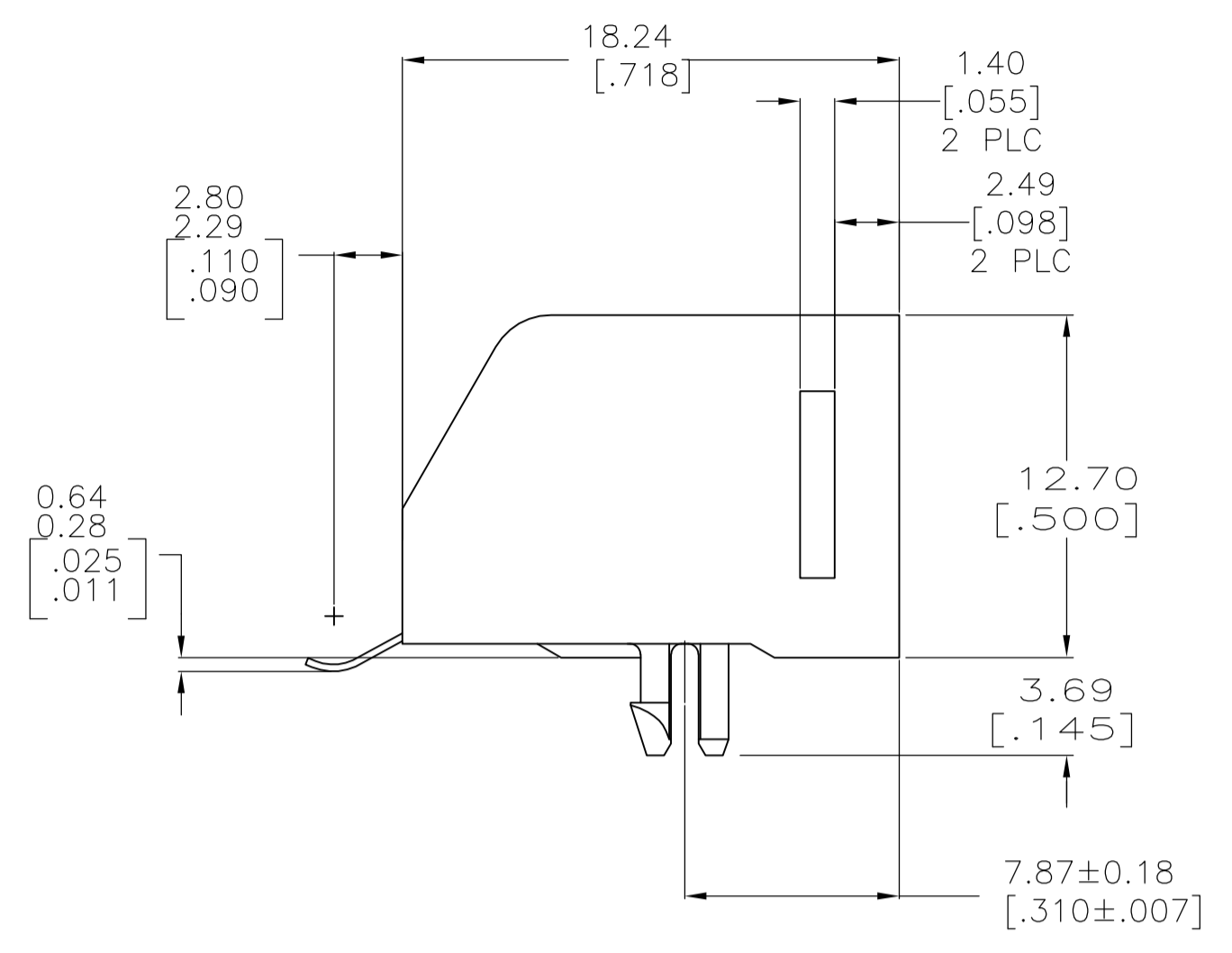

1. MATERIAL: HOUSING - HTN MOLDING COMPOUND, 94 VO, COLOR: BLACK.
 TERMINAL - 0.36 [.014] THICK PHOS-BRONZE PLATE WITH 1.27μm [.000050] MINIMUM THICK HARD GOLD IN LOCALIZED GOLD PLATE AREA AND 3.81μm [.000150] MINIMUM THICK MATTE TIN IN SOLDER AREA OVER 1.27μm [.000050] MINIMUM THICK NICKEL UNDERPLATE.
2. CAVITY CONFORMS TO FCC RULES AND REGULATIONS, PART 68, SUBPART F.
3. ALL DIMENSIONS SHOWN ARE MAXIMUM UNLESS OTHERWISE SPECIFIED AND ARE PRIOR TO SURFACE MOUNT PROCESSING.
4. SNAP-IN RETENTION FEATURE ACCOMMODATES 1.45-1.70 [.062±.005] THICK PRINTED CIRCUIT BOARD.

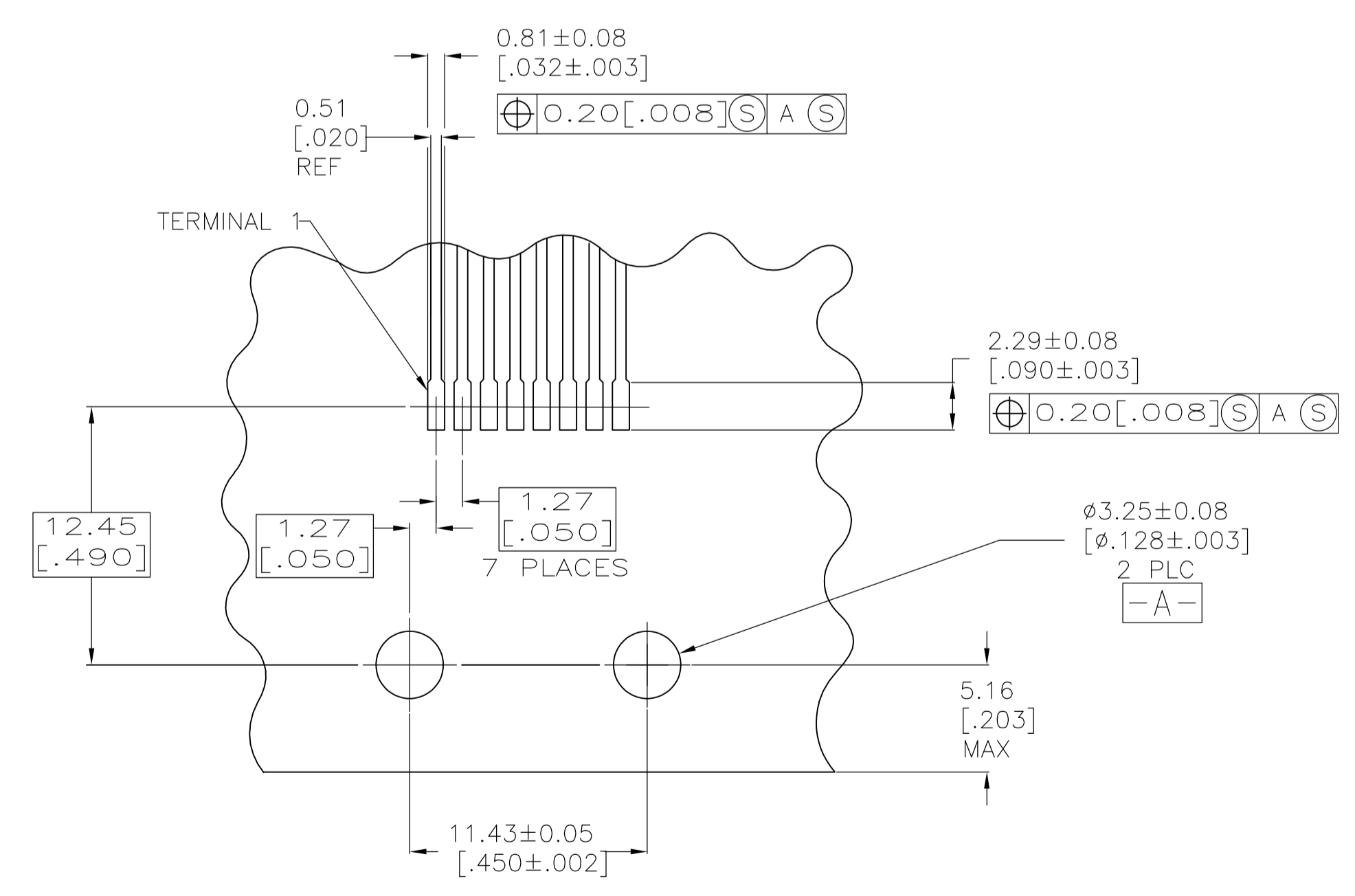
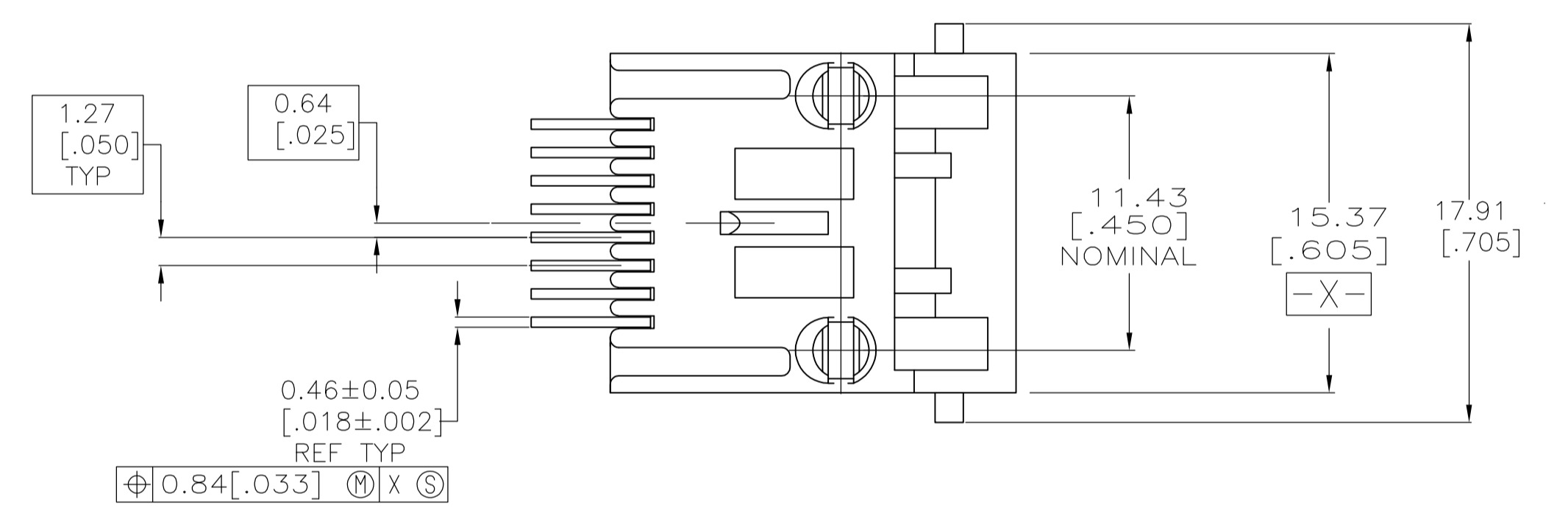

RECOMMENDED PRINTED CIRCUIT BOARD LAYOUT
 COMPONENT SIDE

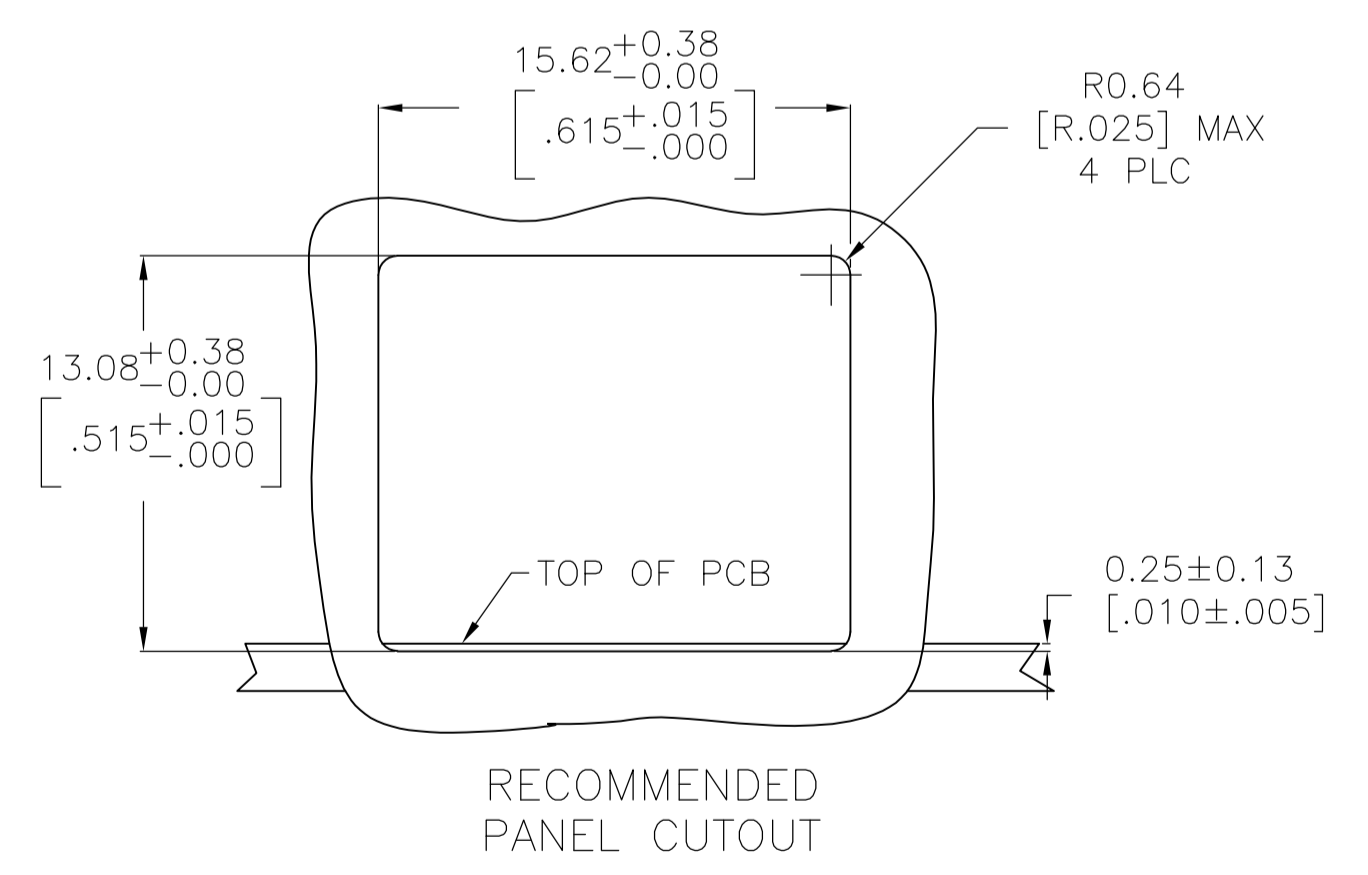

RECOMMENDED
 PANEL CUTOUT

8	5555078-1
NUMBER OF TERMINALS	PART NO

THIS DRAWING IS A CONTROLLED DOCUMENT.		DIN G. ATTADIA - 07JUN2005		Tyco Electronics Tyco Electronics Corporation	
DIMENSIONS: mm [INCHES]		CHK J. WESTMAN 07JUN2005		Harrisburg, PA 17105-3608	
TOLERANCES UNLESS OTHERWISE SPECIFIED:		APVD S. FLICKINGER 07JUN2005		NAME	
0 PLC ± -	1 PLC ± -	PRODUCT SPEC		MODULAR JACK ASSEMBLY, 8 POSITION, LOW PROFILE, RIGHT ANGLE, SURFACE MOUNT, KEYED, WITH PANEL STOPS	
2 PLC ± -	3 PLC ± -	APPLICATION SPEC		108-1163	
4 PLC ± -	ANGLES ± -	114-6040		SIZE CAGE CODE DRAWING NO RESTRICTED TO	
MATERIAL SEE NOTE 1	FINISH SEE NOTE 1	WEIGHT -	A1	©=5555078	-
CUSTOMER DRAWING		SCALE 4:1	SHEET 1 OF 1	REV B	