



Chipsmall Limited consists of a professional team with an average of over 10 year of expertise in the distribution of electronic components. Based in Hongkong, we have already established firm and mutual-benefit business relationships with customers from,Europe,America and south Asia,supplying obsolete and hard-to-find components to meet their specific needs.

With the principle of “Quality Parts,Customers Priority,Honest Operation,and Considerate Service”,our business mainly focus on the distribution of electronic components. Line cards we deal with include Microchip,ALPS,ROHM,Xilinx,Pulse,ON,Everlight and Freescale. Main products comprise IC,Modules,Potentiometer,IC Socket,Relay,Connector.Our parts cover such applications as commercial,industrial, and automotives areas.

We are looking forward to setting up business relationship with you and hope to provide you with the best service and solution. Let us make a better world for our industry!



Contact us

Tel: +86-755-8981 8866 Fax: +86-755-8427 6832

Email & Skype: info@chipsmall.com Web: www.chipsmall.com

Address: A1208, Overseas Decoration Building, #122 Zhenhua RD., Futian, Shenzhen, China



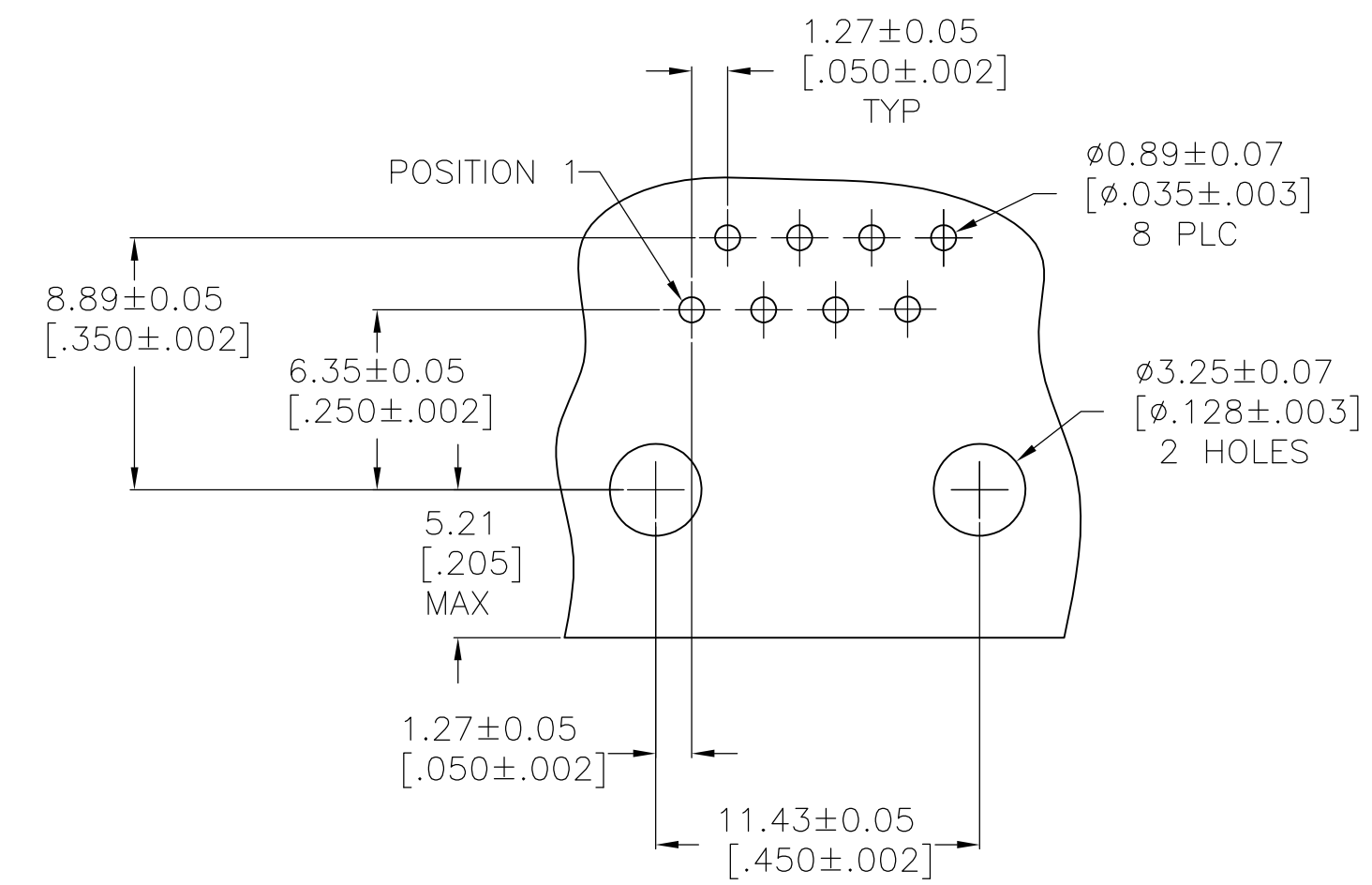
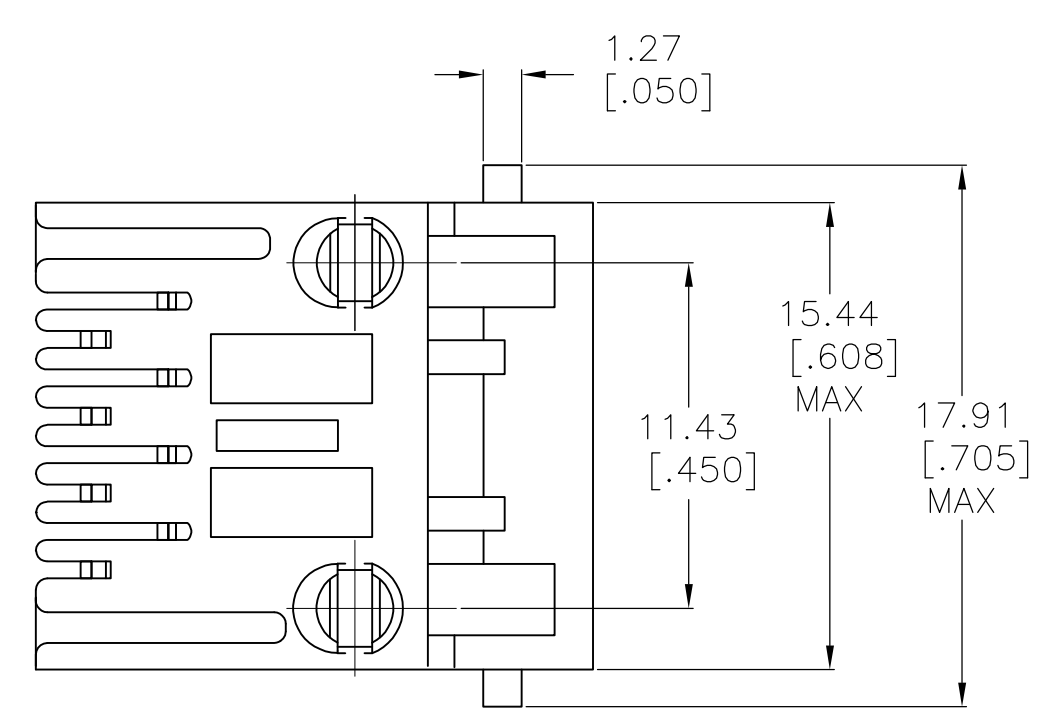
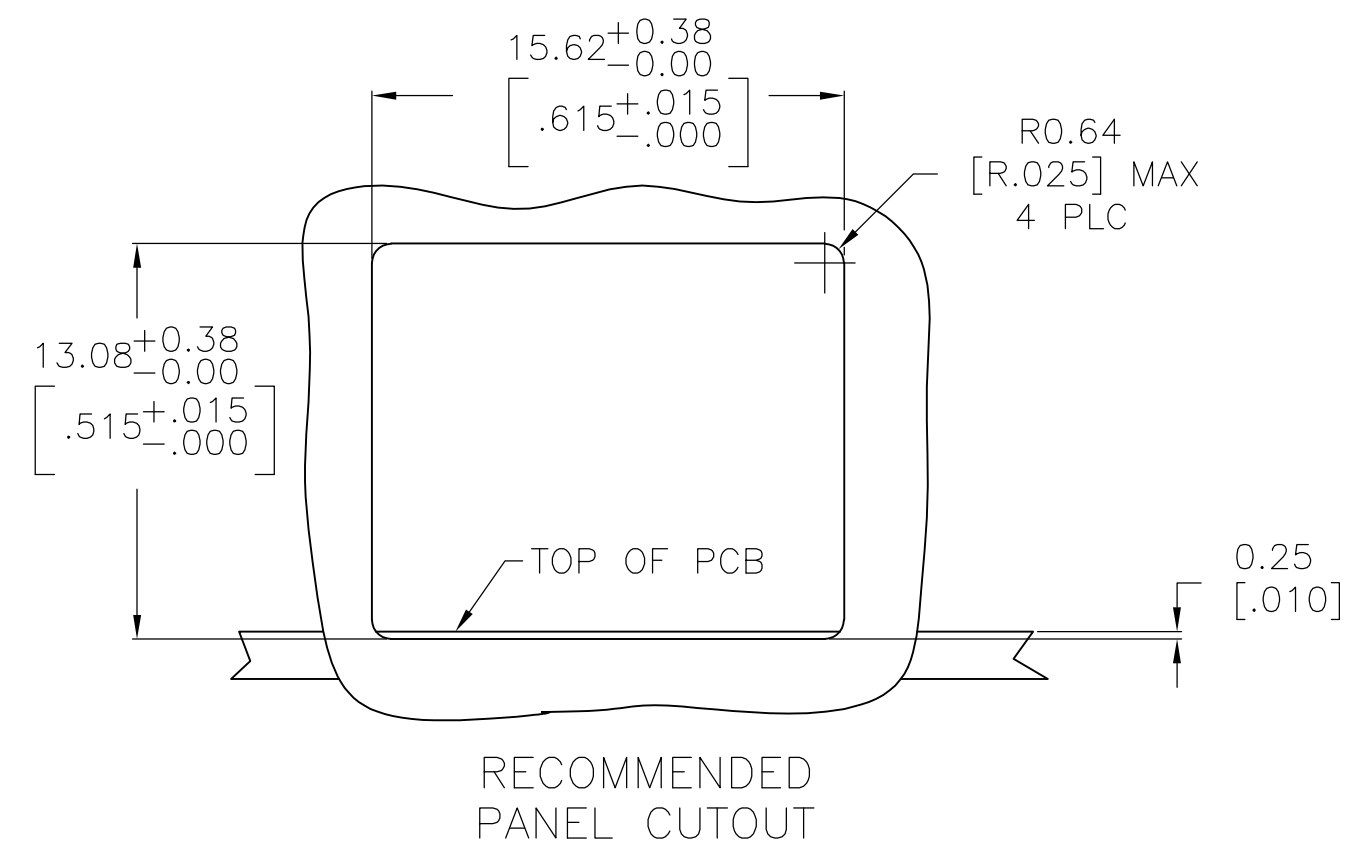
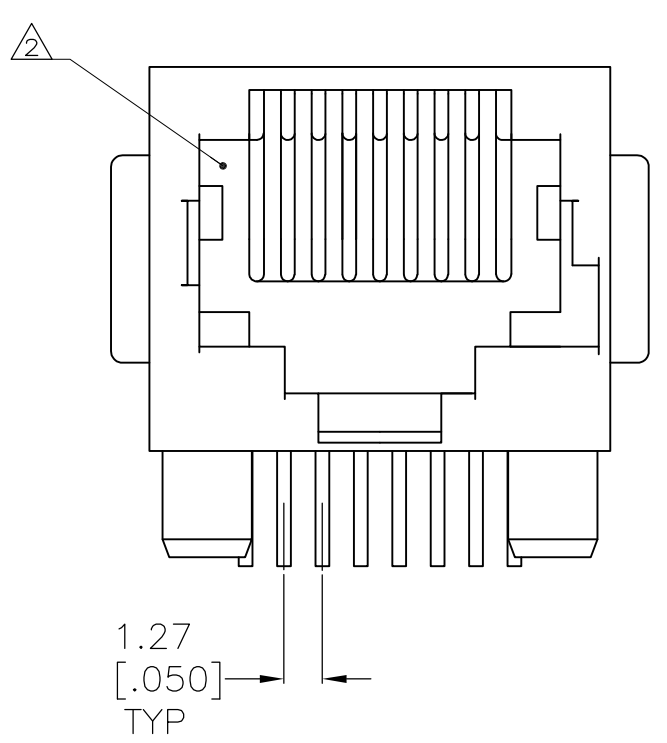
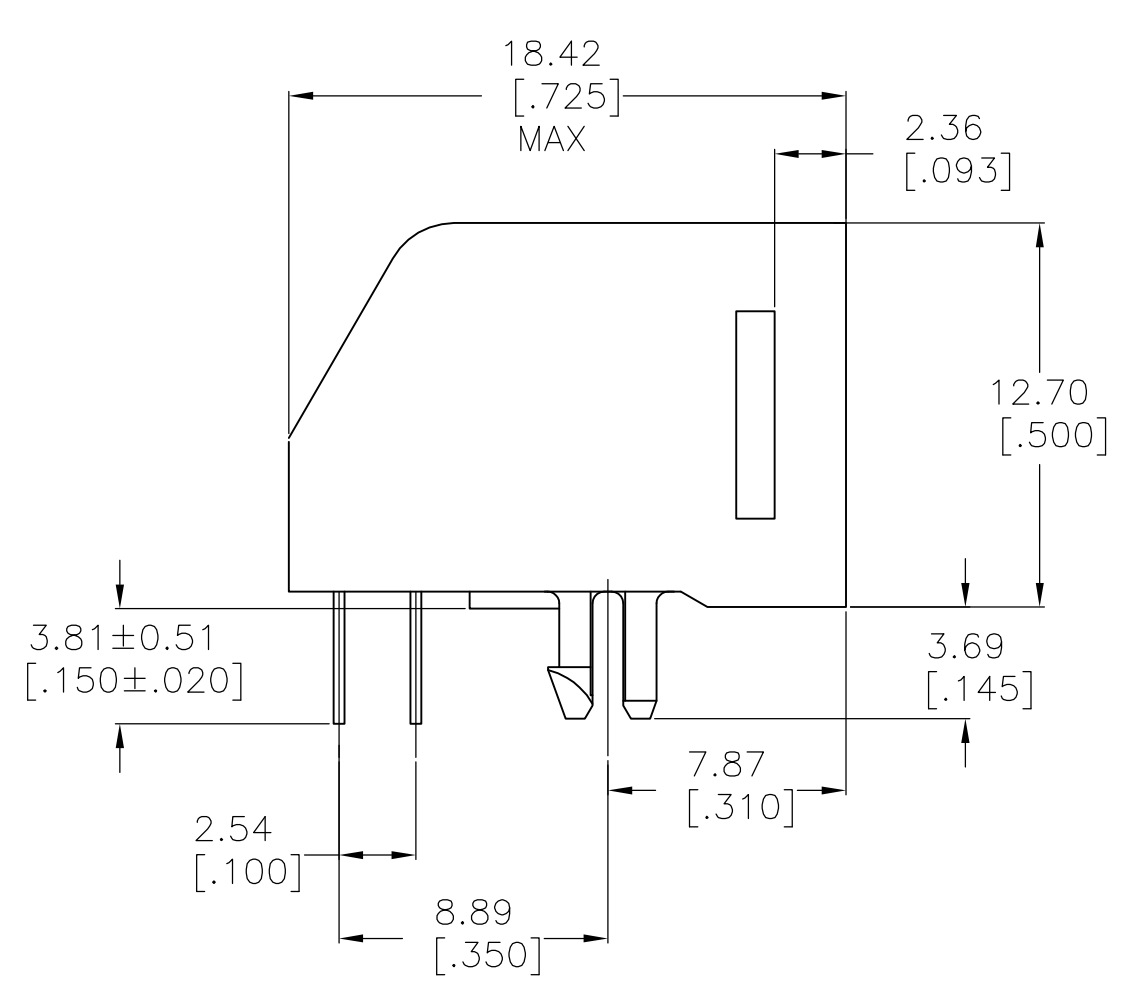

RECOMMENDED PRINTED CIRCUIT BOARD LAYOUT
COMPONENT SIDE SHOWN

- MATERIAL: HOUSING – PBT POLYESTER, COLOR: BLACK
TERMINAL – 0.36 [0.014] THICK PHOS BRONZE PLATED WITH 1.27µm [0.000050] MINIMUM THICK HARD GOLD IN LOCALIZED GOLD PLATE AREA AND 3.81µm [0.000150] MINIMUM THICK MATTE TIN IN SOLDER AREA OVER 1.27µm [0.000050] MINIMUM THICK NICKEL UNDERPLATE.
- △ CAVITY CONFORMS TO FCC RULES AND REGULATIONS PART 68, SUBPART F.

8	5555166-1
TERMINALS	PART NO

THIS DRAWING IS A CONTROLLED DOCUMENT.		DIN GA/LA-MAYER 05MAR2008		STE TE Connectivity	
DIMENSIONS: mm [INCHES]		TOLERANCES UNLESS OTHERWISE SPECIFIED:		NAME	
0 PLC ± -		1 PLC ± -		S. FLICKINGER	
1 PLC ± -		2 PLC ± 0.13[005]		PRODUCT SPEC	
2 PLC ± -		3 PLC ± -		108-1163	
3 PLC ± -		4 PLC ± -		APPLICATION SPEC	
4 PLC ± -		ANGLES ± -		114-2048	
MATERIAL SEE NOTE 1		FINISH SEE NOTE 1		SIZE CAGE CODE DRAWING NO	
				A1 00779 5555166	
				RESTRICTED TO	
				CUSTOMER DRAWING	
				SCALE 4:1 SHEET 1 OF 1 REV D1	