



Chipsmall Limited consists of a professional team with an average of over 10 year of expertise in the distribution of electronic components. Based in Hongkong, we have already established firm and mutual-benefit business relationships with customers from,Europe,America and south Asia,supplying obsolete and hard-to-find components to meet their specific needs.

With the principle of “Quality Parts,Customers Priority,Honest Operation,and Considerate Service”,our business mainly focus on the distribution of electronic components. Line cards we deal with include Microchip,ALPS,ROHM,Xilinx,Pulse,ON,Everlight and Freescale. Main products comprise IC,Modules,Potentiometer,IC Socket,Relay,Connector.Our parts cover such applications as commercial,industrial, and automotives areas.

We are looking forward to setting up business relationship with you and hope to provide you with the best service and solution. Let us make a better world for our industry!



Contact us

Tel: +86-755-8981 8866 Fax: +86-755-8427 6832

Email & Skype: info@chipsmall.com Web: www.chipsmall.com

Address: A1208, Overseas Decoration Building, #122 Zhenhua RD., Futian, Shenzhen, China



THIS DRAWING IS UNPUBLISHED. RELEASED FOR PUBLICATION
 © COPYRIGHT BY TYCO ELECTRONICS CORPORATION. ALL RIGHTS RESERVED.

LOC	DIST	REVISIONS					
AA	22	P	LTR	DESCRIPTION	DATE	DWN	APVD
		A1		REV PER ECR-10-017689	30AUG2010	DZ	MQ.W

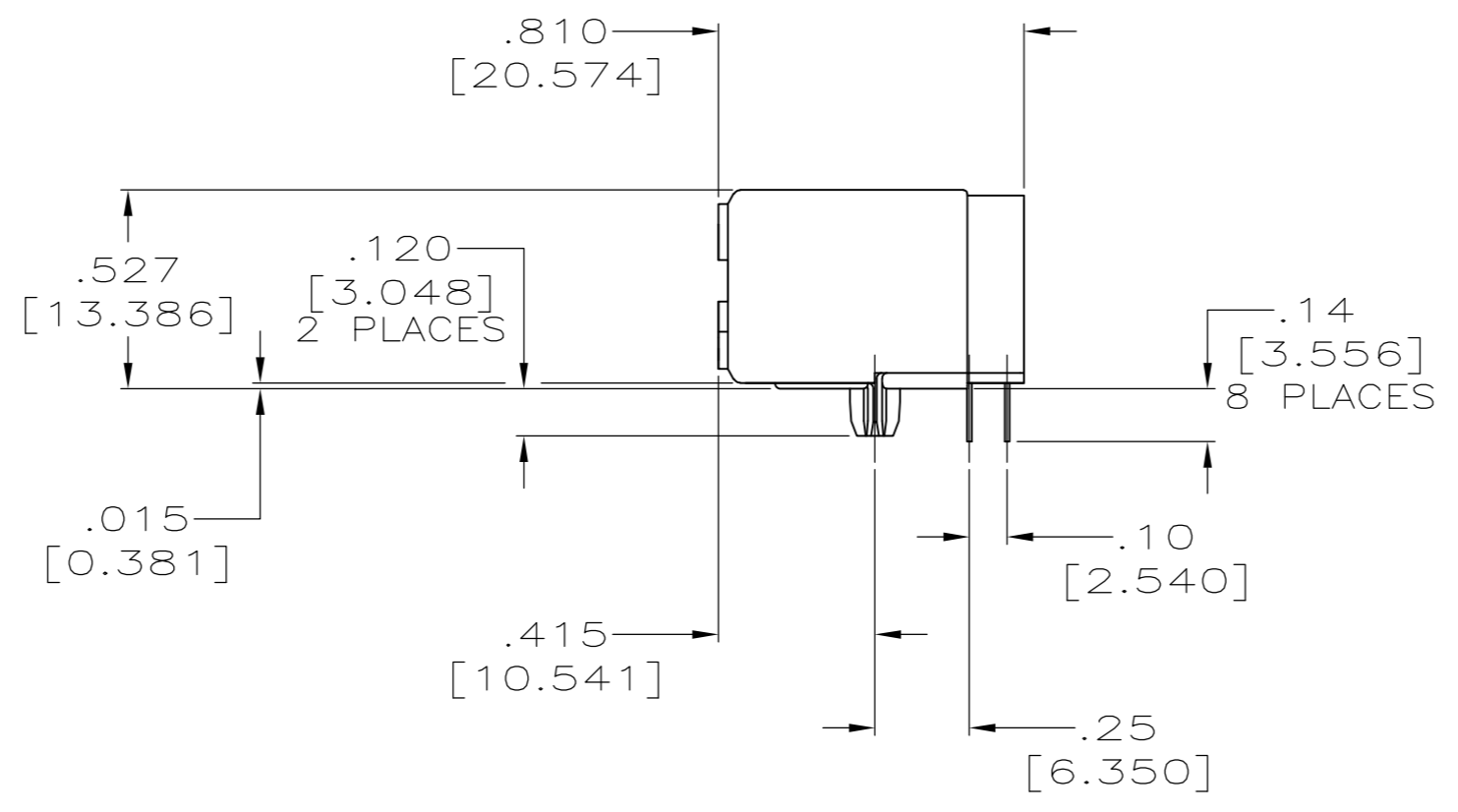
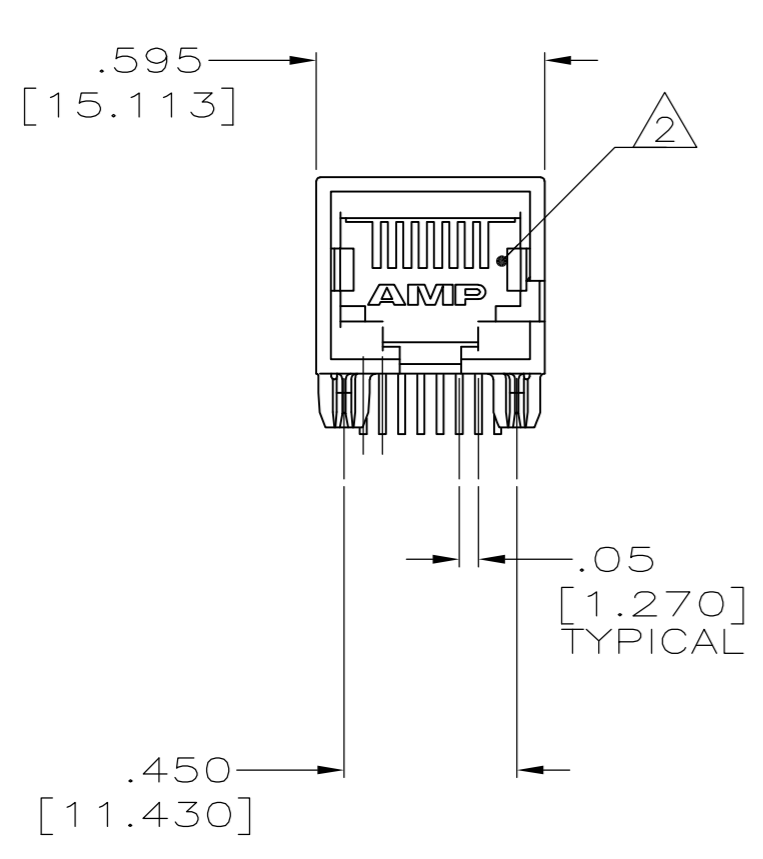

- 1 MATERIAL: HOUSING - HTN NYLON, BLACK, TERMINALS - .013[0.33] THICK PHOS BRONZE PLATED WITH .000050[1.27μm] MINIMUM THICK HARD GOLD IN LOCALIZED AREA AND .000150 [3.81μm] MINIMUM THICK MATTE TIN IN SOLDER AREA OVER .000050[1.27μm] MINIMUM THICK NICKEL UNDERPLATE.
- 2 JACK CAVITY CONFORMS TO FCC RULES AND REGULATIONS, PART 68 SUBPART F.
- 3. ALL DIMENSIONS SHOWN ARE NOMINAL UNLESS OTHERWISE SPECIFIED.
- 4. ALL DIMENSIONS SHOWN IN BRACKETS [] ARE IN MILLIMETERS.
- 5 USE #30 DRILL BIT OR 3.25mm DRILL BIT WHEN PRODUCING THESE PCB HOLES.

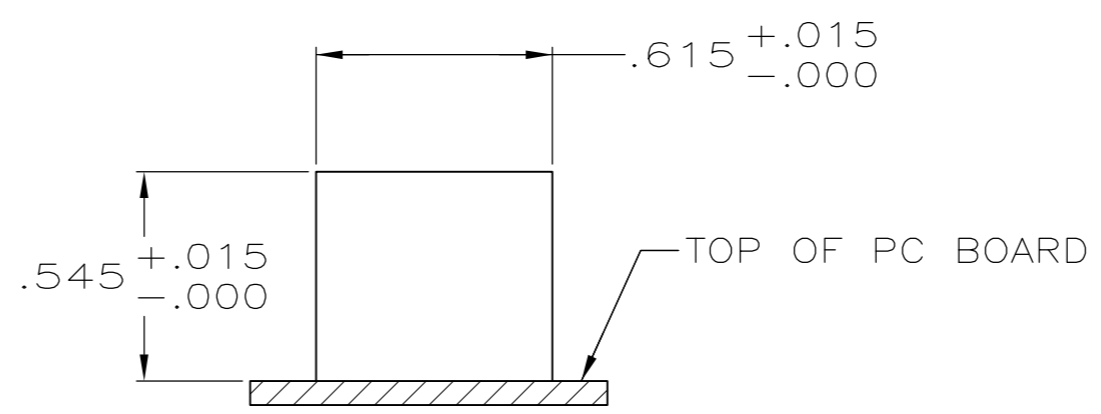
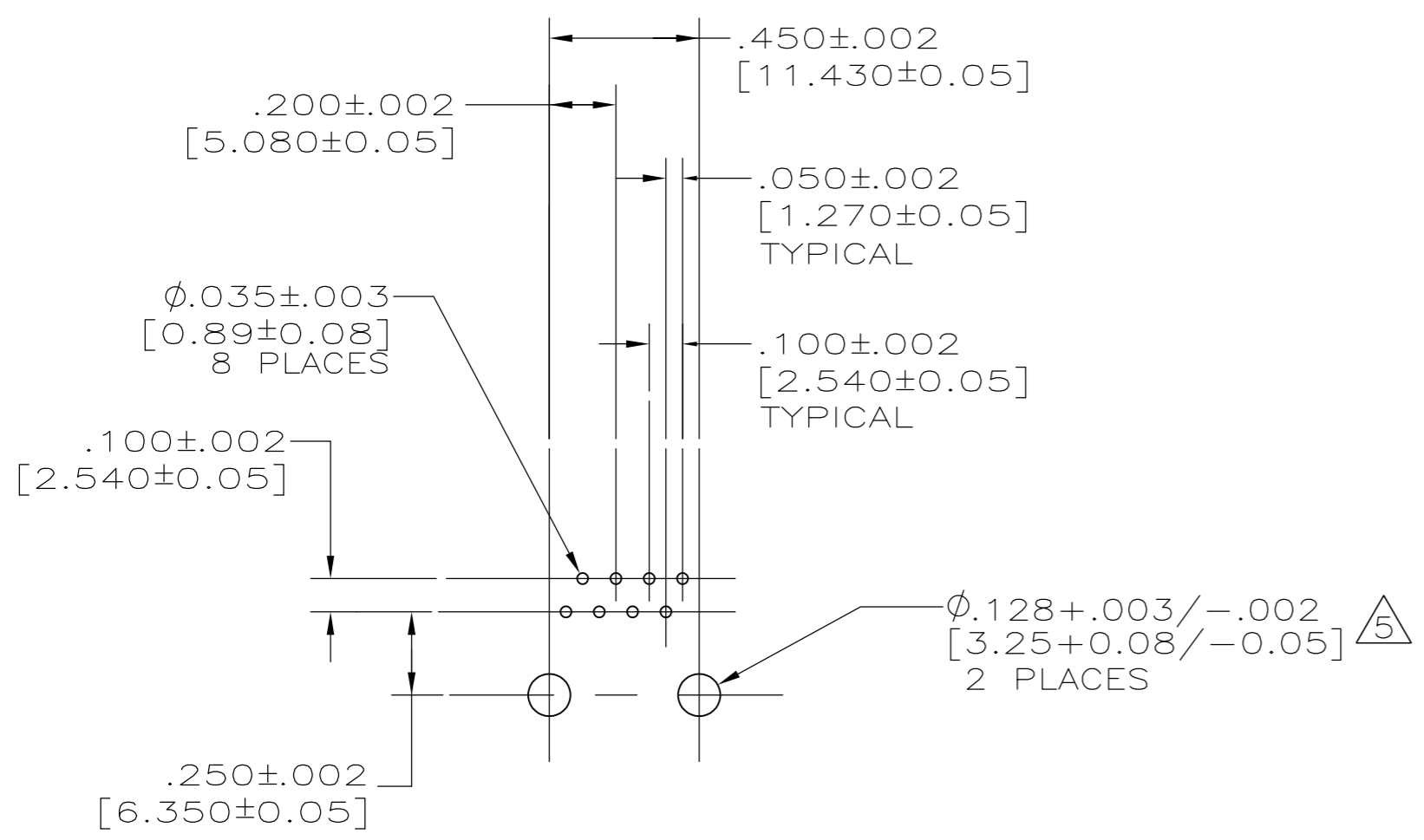

SUGGESTED PANEL CUTOUT

SUGGESTED PC BOARD LAYOUT COMPONENT SIDE

5557804-1
PART NO.

THIS DRAWING IS A CONTROLLED DOCUMENT.		DWN A. FERNANDEZ-DOCK5 03JUN2005	Tyco Electronics Corporation Harrisburg, Pa 17105-3608	
DIMENSIONS: INCHES		CHK J. WESTMAN 03JUN2005	NAME S. FLICKINGER 03JUN2005	
TOLERANCES UNLESS OTHERWISE SPECIFIED:		PRODUCT SPEC 108-1163		RESTRICTED TO
0 PLC ± -		APPLICATION SPEC 114-2048		SIZE A2
1 PLC ± -		WEIGHT -		CAGE CODE 00779
2 PLC ± .01[0.254]		DRAWING NO C=5557804		SCALE 1:1
3 PLC ± .005[0.127]		SHEET 1 OF 1		REV A1
4 PLC ± -		CUSTOMER DRAWING		
ANGLES ± -				
FINISH				