



Chipsmall Limited consists of a professional team with an average of over 10 year of expertise in the distribution of electronic components. Based in Hongkong, we have already established firm and mutual-benefit business relationships with customers from,Europe,America and south Asia,supplying obsolete and hard-to-find components to meet their specific needs.

With the principle of “Quality Parts,Customers Priority,Honest Operation,and Considerate Service”,our business mainly focus on the distribution of electronic components. Line cards we deal with include Microchip,ALPS,ROHM,Xilinx,Pulse,ON,Everlight and Freescale. Main products comprise IC,Modules,Potentiometer,IC Socket,Relay,Connector.Our parts cover such applications as commercial,industrial, and automotives areas.

We are looking forward to setting up business relationship with you and hope to provide you with the best service and solution. Let us make a better world for our industry!



Contact us

Tel: +86-755-8981 8866 Fax: +86-755-8427 6832

Email & Skype: info@chipsmall.com Web: www.chipsmall.com

Address: A1208, Overseas Decoration Building, #122 Zhenhua RD., Futian, Shenzhen, China





Copyright FCI.

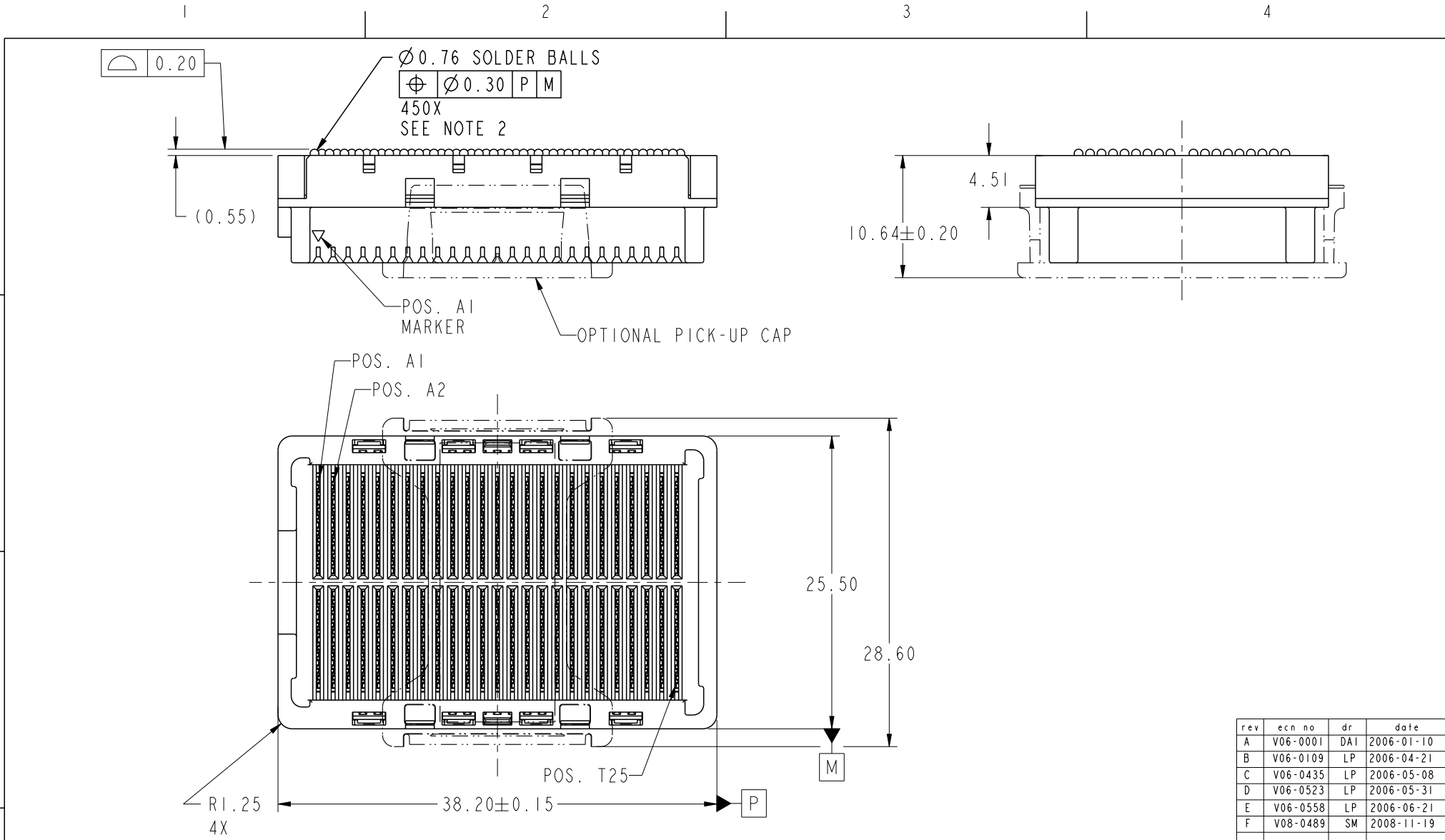

rev	ecn no	dr	date
A	V06-0001	DAI	2006-01-10
B	V06-0109	LP	2006-04-21
C	V06-0435	LP	2006-05-08
D	V06-0523	LP	2006-05-31
E	V06-0558	LP	2006-06-21
F	V08-0489	SM	2008-11-19

spec ref	*	dr	Bill Lin	2010/02/02	projection	mm	size	A4	scale	1:10	
tolerance std	ASME Y14.5	eng	Nickor Zuo	2011/06/09			ecn no	ELX-DG-003943-1			
		chr	Alex Cao	2011/06/24				rel level	Released		
surface	✓	appr	Pei-Ming Zheng	2011/06/27	product family	GIG-Array		rel level	Released		
					title	GIG-Array		dwg no	55740		
						5mm RECP. ASSY. 200 SIG. POS.				rev	G
					cat. no.	Product - Customer Drw			sheet 1 of 5		

ProjE File - REV C - 2009-06-09



Copyright FCI.

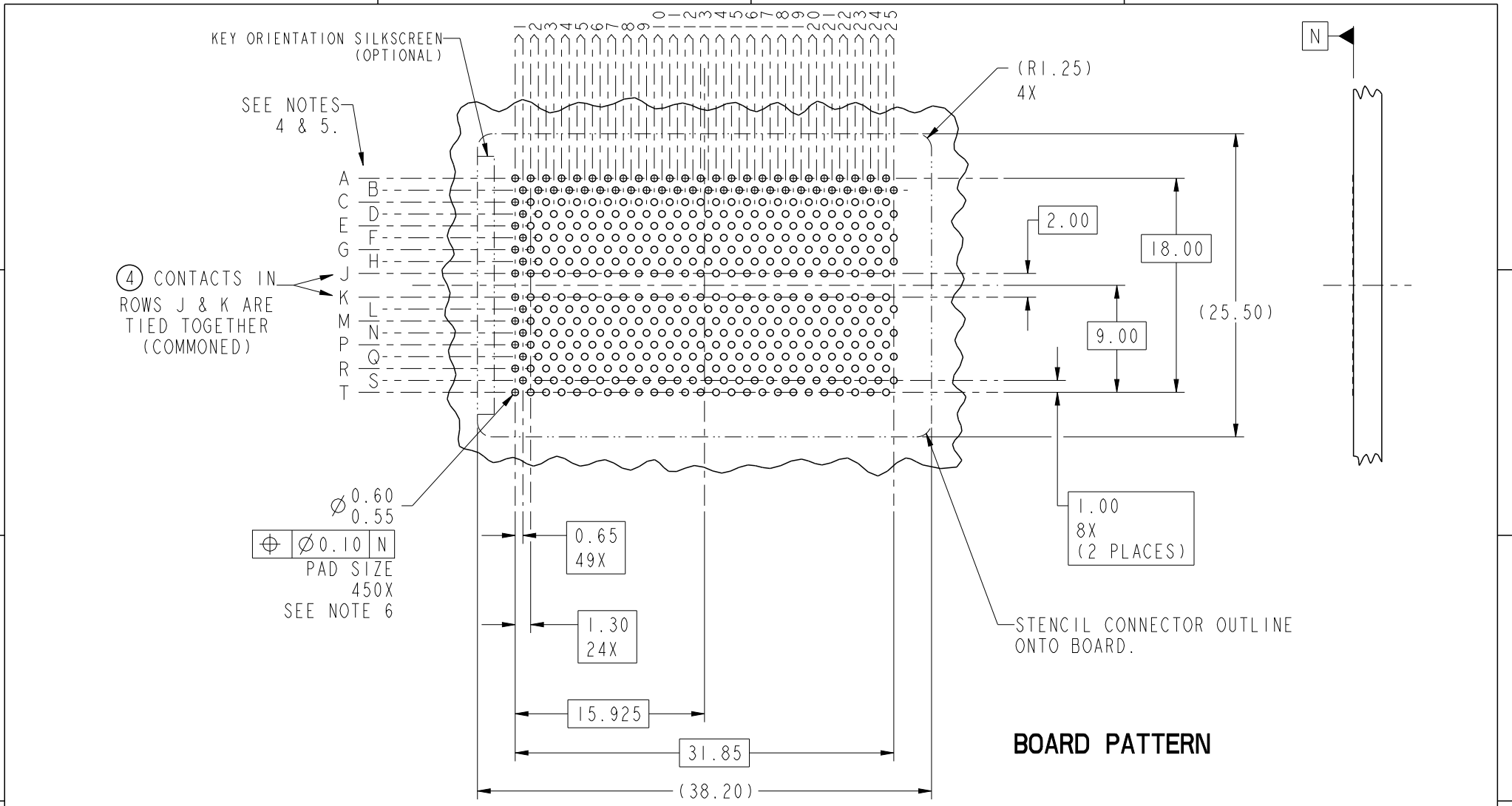

spec ref	*	dr	Bill Lin	2010/02/02	projection	mm	size	A4	scale	1:10
tolerance std	ASME Y14.5	eng	Nickor Zuo	2011/06/09			ecn no		ELX-DG-003943-1	
TOLERANCES UNLESS OTHERWISE SPECIFIED		chr	Alex Cao	2011/06/24			rel level		Released	
surface	✓	appr	Pei-Ming Zheng	2011/06/27	product family		GIG-Array		rev	
	linear				title		GIG-Array		dwg no	55740
					5mm RECP. ASSY. 200 SIG. POS.					G
	angular				cat. no.	*	Product - Customer Drw		sheet 2 of 5	

ProjE File - REV C - 2009-06-09

A

B

C

D

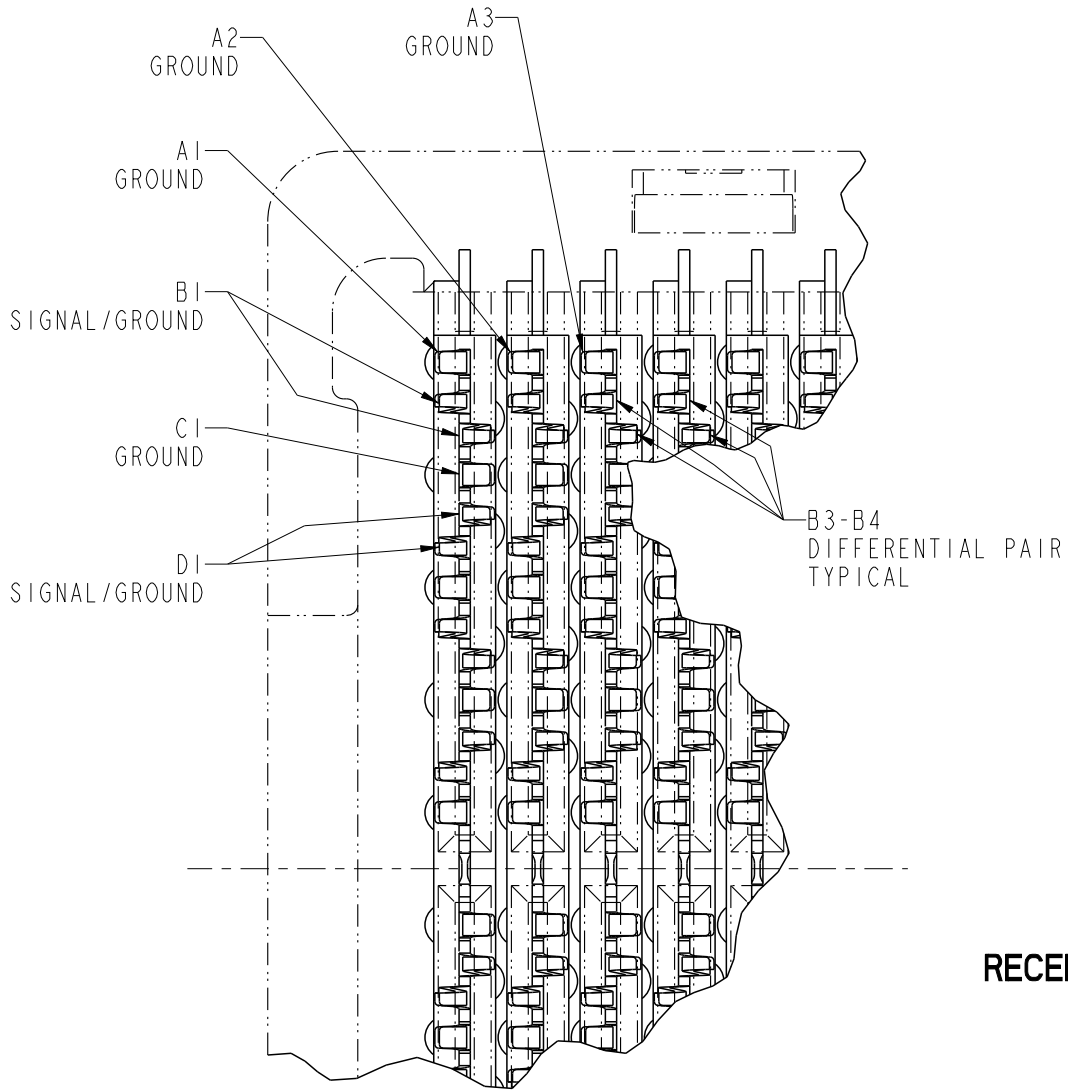

RECEPTACLE INTERFACE DESCRIPTION



Copyright FCI.

spec ref *		dr Bill Lin 2010/02/02		projection 	mm 	size A4	scale 37:5
tolerance std ASME Y14.5		eng Nickor Zuo 2011/06/09				ecn no ELX-DG-003943-1	
-		chr Alex Cao 2011/06/24				rel level Released	
surface		linear	0.X ±0.30	FCI	title GIG-Array	dwg no 55740	rev G
-			0.XX ±0.10				
			0.XXX ±0.05	www.fci.com	cat. no. *	Product - Customer Drw	
		angular	0° ±2°			sheet 3 of 5	

PreE File - REV C - 2009-06-09

**FLAT AREA
FOR OPTIONAL
PICK-UP CAP**
SCALE 2:1

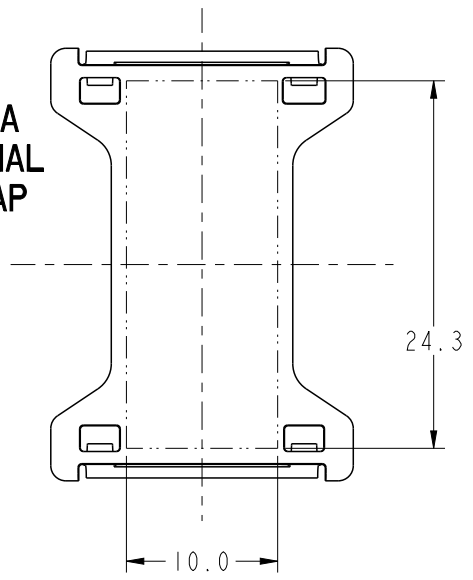

DIM "A" REF.
MATED HEIGHT
AFTER REFLOW
SEE NOTE 3.

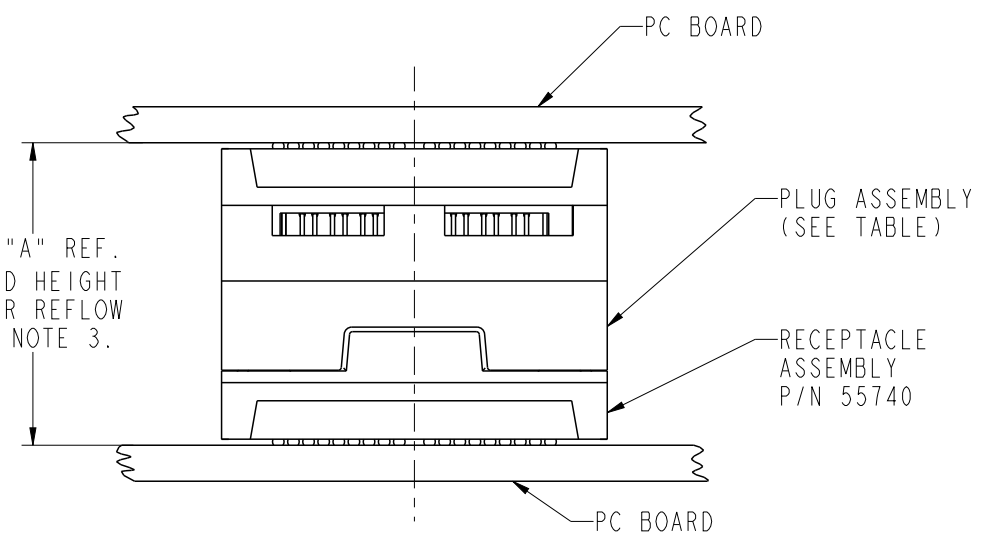

END VIEW OF MATED CONNECTORS
SCALE 2:1

DIM. "A"	PLUG ASSEMBLY P/N
15	55737
17	10026802
18	10030626
20	55738
25	55739
30	10054783



Copyright FCI.

spec ref	*	dr	Bill Lin	2010/02/02	projection 	mm 	size	A4	scale	1:1:10				
tolerance std	TOLERANCES UNLESS OTHERWISE SPECIFIED	eng	Nickor Zuo	2011/06/09			ecn no	ELX-DG-003943-1						
ASME Y14.5		chr	Alex Cao	2011/06/24				rel level	Released					
-		appr	Pei-Ming Zheng	2011/06/27			product family		GIG-Array					
surface	linear	0.X	±0.30	www.fci.com	title	GIG-Array	dwg no	55740	rev	G				
		0.XX	±0.10								cat. no.	*	Product - Customer Drw	sheet 4 of 5
		0.XXX	±0.05											
	angular	0°	±2°											

PrdE File - REV C - 2009-06-09

PRODUCT NUMBER	SOLDER BALL COMPOSITION	CONTACT PLATING PERFORMANCE LEVEL
55740-001	STANDARD (EUTECTIC)	PERFORMANCE-BASED PLATING, QUALIFIED TO MEET THE REQUIREMENTS OF FCI PRODUCT SPECIFICATION GS-12-192, INCLUDING TELCORDIA CENTRAL OFFICE
55740-001LF	LEADFREE	
55740-201	STANDARD (EUTECTIC)	Au over Ni
55740-201LF	LEADFREE	

NOTES:

- ① MATERIAL:
HOUSING: LCP
CONTACT: COPPER ALLOY
PLATING (CONTACT): SEE TABLE.
UL RATING: 94 V-0
SOLDBALL: (SEE TABLE) EUTECTIC
SnPb OR LEAD FREE 95.5 Sn/4Ag/0.5Cu.
- ② SOLDER BALLS WILL NOT BE PERFECT SPHERICAL SHAPE DUE TO REFLOW ATTACHMENT.
- ③ MATED HEIGHT EFFECTED BY CUSTOMERS' PCB PAD SIZE, PLATING, SOLDER REFLOW PROFILE & SOLDER PASTE.
- ④ CONTACTS IN ROWS A,C,E,G,J,K,M,P,R AND T ARE SINGLE BEAM CONTACTS, TYPICALLY USED AS GROUND PINS.
(NOTE: CONTACTS IN ROWS J & K ARE TIED TOGETHER [COMMONED])
- ⑤ CONTACTS IN ROWS B,D,F,H,L,N,Q AND S ARE DUAL BEAM CONTACTS, TYPICALLY USED AS SIGNAL PINS.
- ⑥ SPECIFIED POSITIONAL TOLERANCE DEFINES PAD TO PAD LOCATION WITHIN LAND PATTERN. POSITIONAL TOLERANCE OF LAND PATTERN TO FUDICIAL MARKS OR PCB DATUMS SHALL BE DEFINED BY CUSTOMER. FOR RECOMMENDED PRODUCT APPLICATION AND PCB DESIGN DETAILS, SEE DOC. NO. GS-20-016.
- ⑦ FOR PROPER APPLICATION FOLLOW FCI APPLICATION SPECIFICATION GS-20-033. LEAD FREE SOLDER BALLS WILL NOT SOLDER PROPERLY IN A LEADED SOLDER PROCESS DUE TO A HIGHER REFLOW TEMPERATURE. LEADFREE PRODUCT IS THEREFORE NOT BACKWARDS COMPATIBLE WITH LEADED OR SOME SOLDERING APPLICATIONS. REFERENCE FCI APPLICATION SPECIFICATION.
- ⑧ THIS PRODUCT MEETS THE EUROPEAN UNION DIRECTIVES AND OTHER COUNTRY REGULATIONS AS DESCRIBED IN GS-22-008. PRODUCT MEETING THIS DIRECTIVE IS IDENTIFIED IN THE CODE NUMBER MARKED ON EACH PART BY HAVING AN "X" IN THE SEVENTH CHARACTER POSTION.

spec ref	*	dr	Bill Lin	2010/02/02	projection 	mm 	size	A4	scale	1:10
tolerance std	TOLERANCES UNLESS OTHERWISE SPECIFIED	eng	Nickor Zuo	2011/06/09			ecn no	ELX-DG-003943-1		
ASME Y14.5		chr	Alex Cao	2011/06/24			product family	GIG-Array		
-		appr	Pei-Ming Zheng	2011/06/27	rel level	Released				
surface	✓	linear	0.X	±0.30		title	GIG-Array	dwg no	55740	rev
-			0.XX	±0.10						
			0.XXX	±0.05						
	angular	0°	±2°	www.fci.com	cat. no.	*	Product - Customer Drw	sheet 5 of 5		