



Chipsmall Limited consists of a professional team with an average of over 10 year of expertise in the distribution of electronic components. Based in Hongkong, we have already established firm and mutual-benefit business relationships with customers from,Europe,America and south Asia,supplying obsolete and hard-to-find components to meet their specific needs.

With the principle of “Quality Parts,Customers Priority,Honest Operation,and Considerate Service”,our business mainly focus on the distribution of electronic components. Line cards we deal with include Microchip,ALPS,ROHM,Xilinx,Pulse,ON,Everlight and Freescale. Main products comprise IC,Modules,Potentiometer,IC Socket,Relay,Connector.Our parts cover such applications as commercial,industrial, and automotives areas.

We are looking forward to setting up business relationship with you and hope to provide you with the best service and solution. Let us make a better world for our industry!



Contact us

Tel: +86-755-8981 8866 Fax: +86-755-8427 6832

Email & Skype: info@chipsmall.com Web: www.chipsmall.com

Address: A1208, Overseas Decoration Building, #122 Zhenhua RD., Futian, Shenzhen, China



LOC		DIST		REVISIONS			
P	LTR	DESCRIPTION	DATE	DMN	APVD		
A		REVISED PER ECN 0512-0303-05	17APR06	JDP	GES		
B		ECR-10-018652	10SEP10	JS	MQW		

CONNECTOR ASSEMBLY EXAMPLARY LOADED

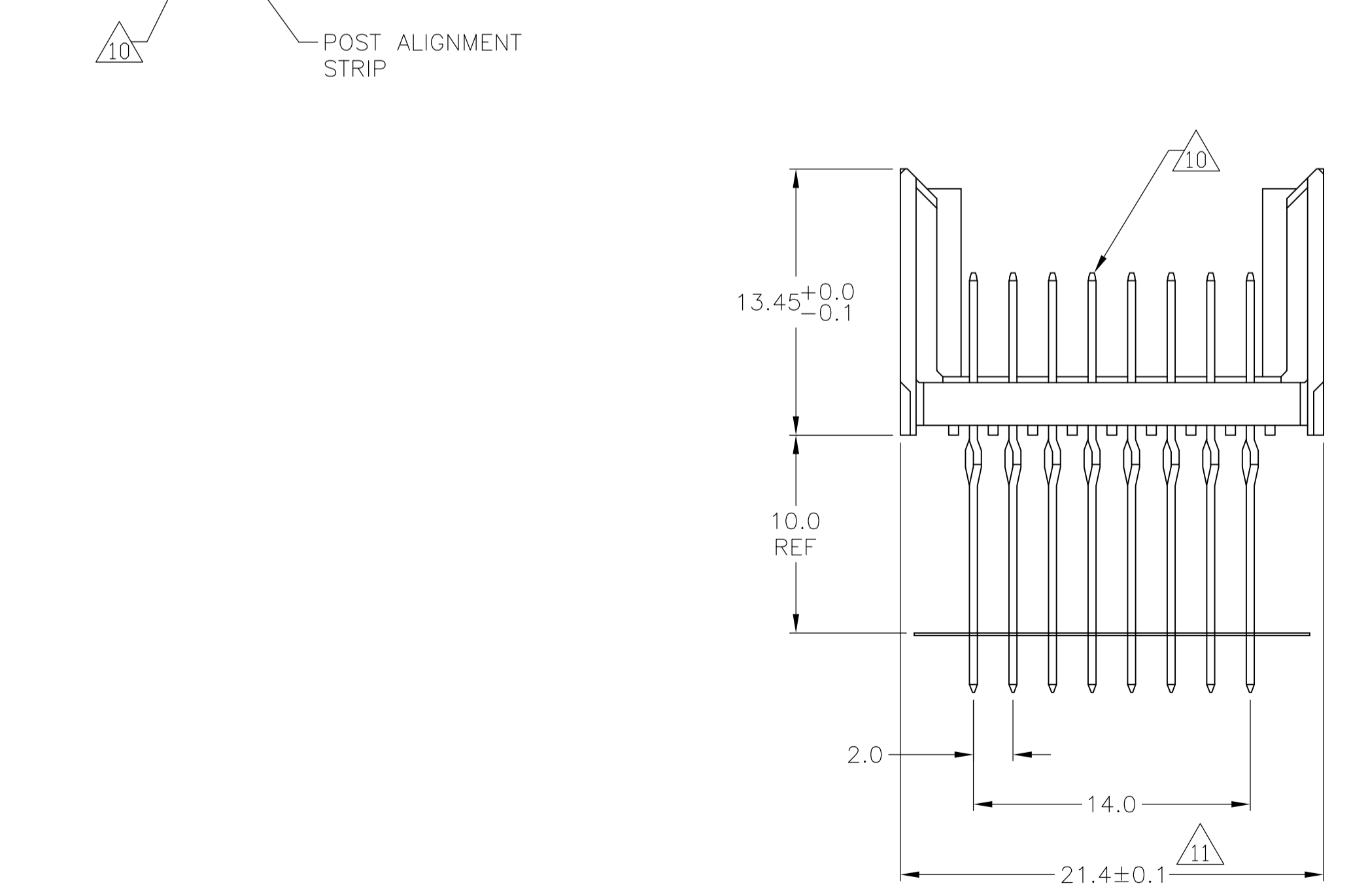
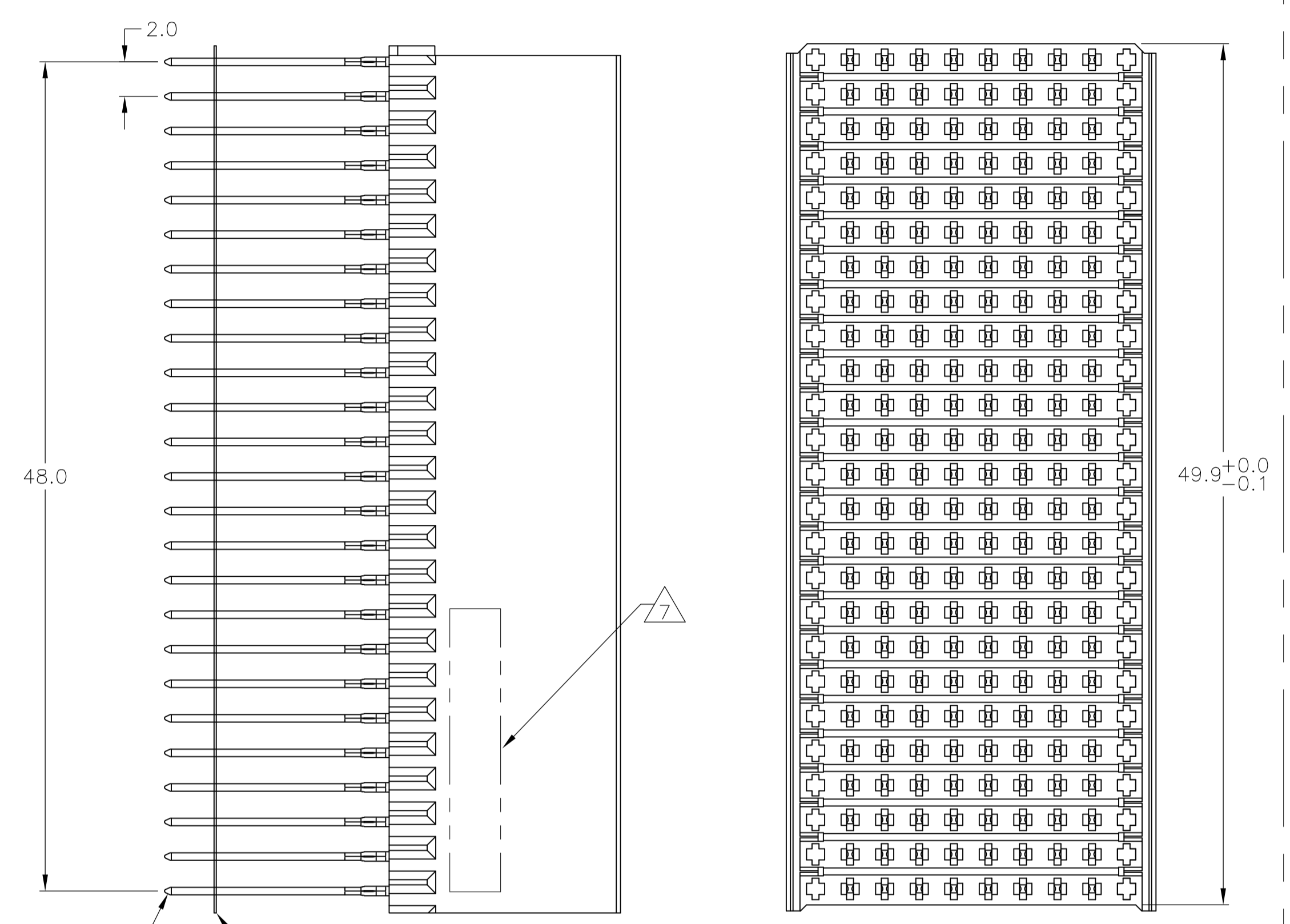

CONTACT DIMENSIONS SCALE 5:1

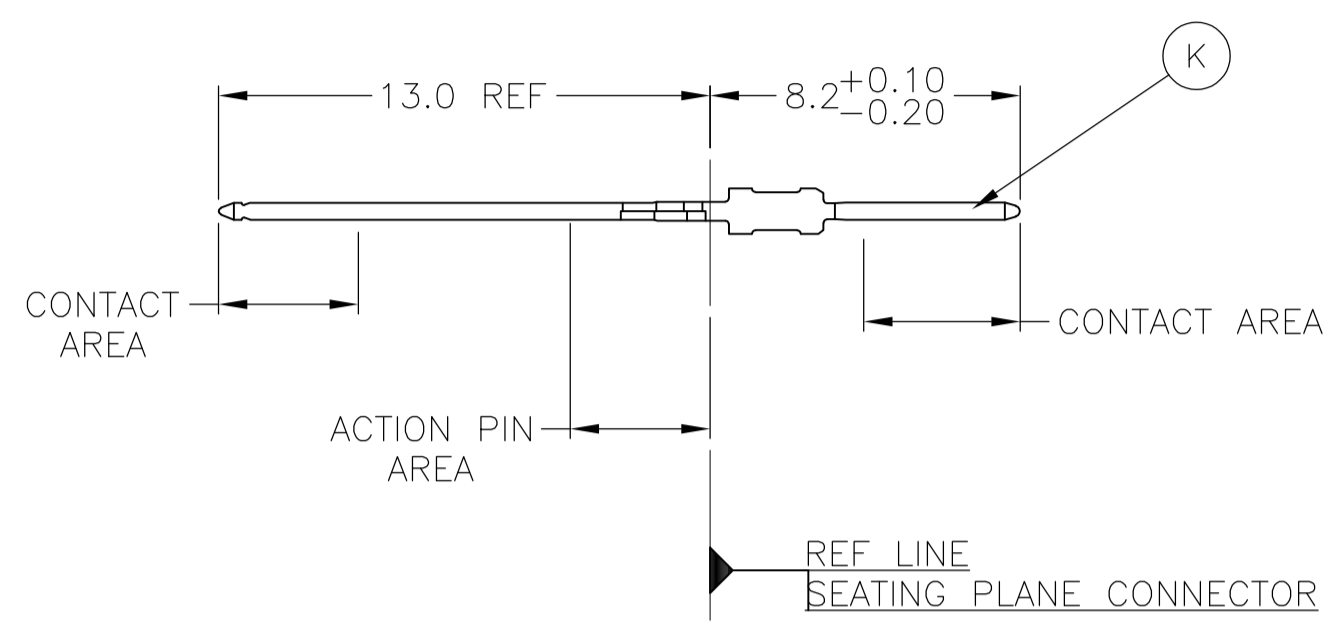

CONTACT LAYOUT

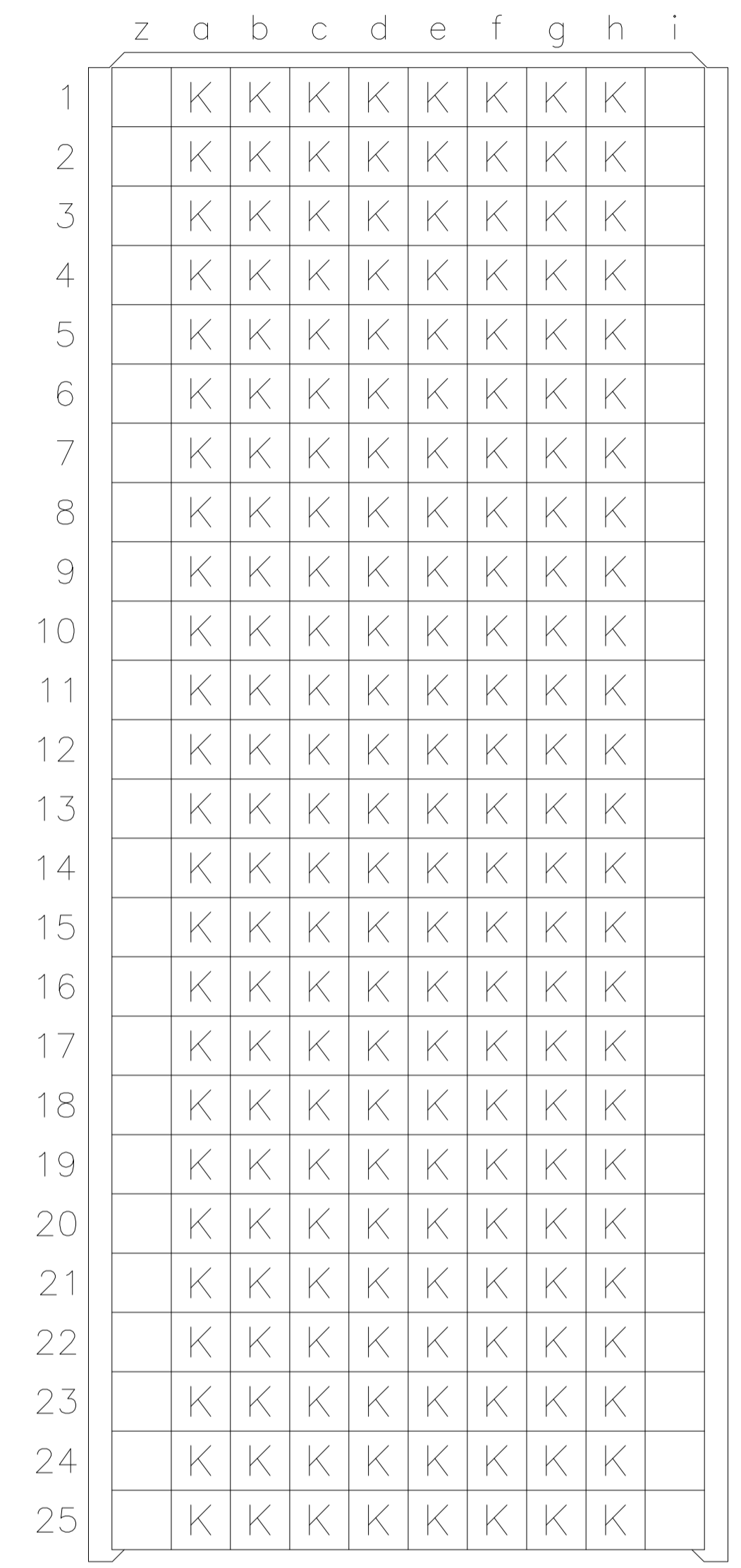

RECOMMENDED PCB-HOLE LAYOUT COMPONENT SIDE SHOWN

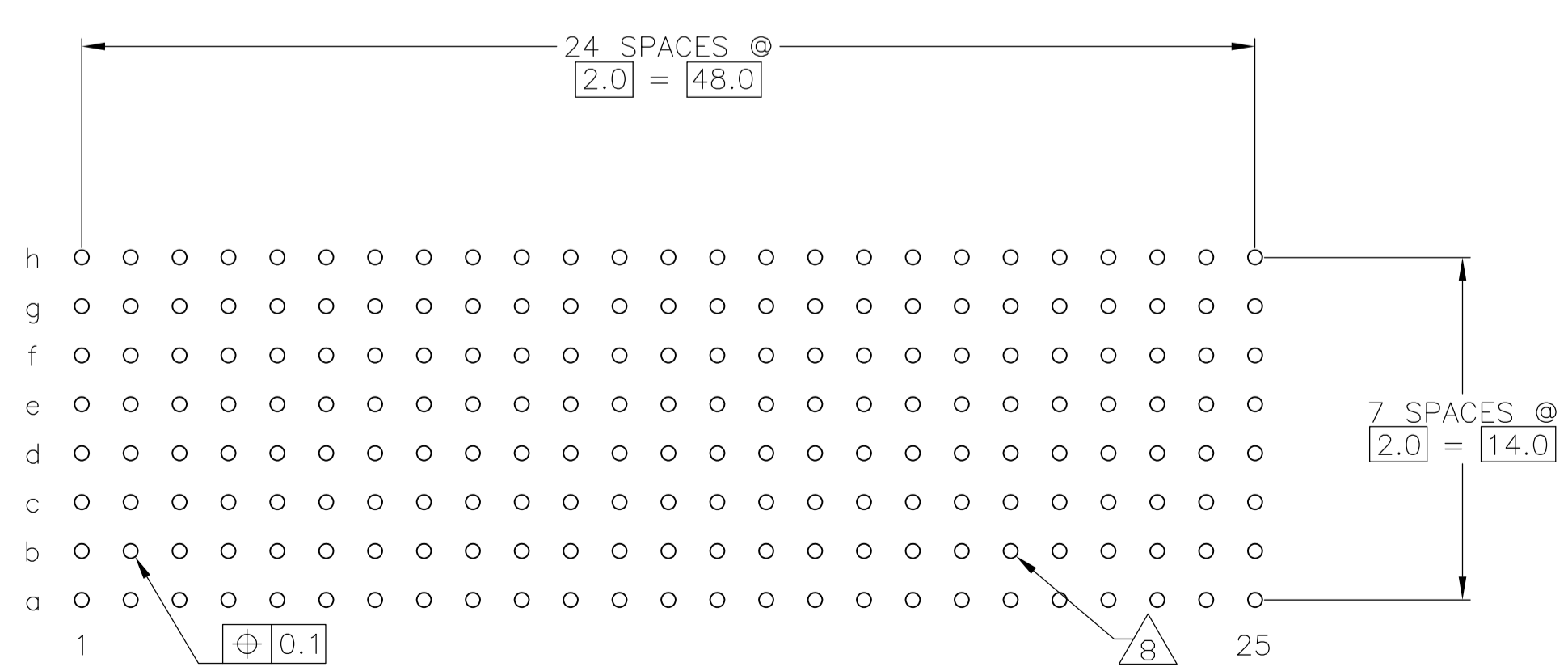

PLATED THRU HOLES PARAMETERS REFERENCE APPLICATION SPECIFICATION

2 6 12	1-5646373-9
2 5 12	5646373-9
2 4	5646373-4
2 3	5646373-1
FINISH	PART NUMBER

THIS DRAWING IS A CONTROLLED DOCUMENT.

DIMENSIONS: mm	TOLERANCES UNLESS OTHERWISE SPECIFIED:	APVD: G. SKIPPER	DATE: 13JUL05		Tyco Electronics Corporation Harrisburg, Pa 17105-3608
0-PLC ±	1-PLC ±0.1	13JUL05	NAME: G. SKIPPER		MALE ASSEMBLY, Z-PACK 2mm HM, TYPE E
2-PLC ±	3-PLC ±	4-PLC ±	5-PLC ±	6-PLC ±	7-PLC ±
MATERIAL: 1	FINISH: SEE TABLE	WEIGHT: -	SIZE: A1	CAGE CODE: 00779	DRAWING NO: 5646373
CUSTOMER DRAWING			SCALE: 4:1	SHEET: 1 OF 2	REV: B

LOC		DIST		REVISIONS				
P	LTR	DESCRIPTION	DATE	DN	APVD			
-	-	SEE SHEET 1	-	-	-			

- 1 MATERIAL:
CONTACT: PHOSPHOR BRONZE.
HOUSING: GLASS-FILLED POLYESTER.
- 2 GENERAL PLATING SPECIFICATION: UNDERPLATING
(ENTIRE CONTACT): 1.27µm MIN NICKEL AND ACTION
PIN: 0.5µm MIN TIN.
FOR PLATING OF MATING SURFACES SEE APPLICABLE
SPECIFICATION REFERENCE FOR EACH DASH NUMBER.
- 3 CONFORMS TO ALL TESTING ACCORDING TO IEC 61076-4-101
PERFORMANCE LEVEL 2.
- 4 CONFORMS TO ALL TESTING ACCORDING TO IEC 61076-4-101
PERFORMANCE LEVEL 1.
- 5 CONNECTOR TESTED AND QUALIFIED AGAINST TELCORDIA GR-1217-CORE QUALITY LEVEL 3,
CENTRAL OFFICE APPLICATIONS.
- 6 CONNECTOR TESTED AND QUALIFIED AGAINST TELCORDIA GR-1217-CORE QUALITY LEVEL 3,
UNCONTROLLED ENVIROMENT APPLICATIONS.
- 7 CONNECTOR MARKED WITH PART NUMBER AND DATE CODE.
ADDITIONAL CHARACTERS OR MARKINGS, AS WELL AS THE LOCATION OF THE MARKINGS,
MAY BE ADDED FOR TRACEABILITY BASED UPON MANUFACTURERS DISCRETION.
- 8 PLATED-THROUGH HOLES AT 2x2mm SQUARE GRID
PATTERN DEFINED BY CONTACT LAYOUT.
- 9 FOR ACTUAL PIN LOADING SEE "CONTACT LAYOUT".
- 10 FOR ACTUAL PIN DIMENSIONS SEE "CONTACT DIMENSIONS".
- 11 TO BE MEASURED AT BOTTOM OF SHROUD.
- 12 CONNECTOR LUBRICATED WITH BELCORE APPROVED LUBRICANT,
TECHNICAL REFERENCE: TR-NWT-001217 ISSUE 1, SEP 1992.

THIS DRAWING IS A CONTROLLED DOCUMENT.		DN S. WAITMAN 13JUL05	Tyco Electronics Corporation Harrisburg, Pa 17105-3608	
DIMENSIONS: mm		CHK G. SKIPPER 13JUL05	NAME Tyco Electronics	
TOLERANCES UNLESS OTHERWISE SPECIFIED: 0-PLG ± 1-PLG ±0.1 2-PLG ± 3-PLG ± 4-PLG ± ANGLES ±1°		APVD G. SKIPPER 13JUL05	PRODUCT SPEC 108-1622	
MATERIAL SEE SHEET 1		FINISH SEE SHEET 1	APPLICATION SPEC 114-19029	RESTRICTED TO -
WEIGHT -		SIZE A1	CAGE CODE 00779	DRAWING NO 5646373
CUSTOMER DRAWING		SCALE 4:1	SHEET 2	OF 2 REV B