



Chipsmall Limited consists of a professional team with an average of over 10 year of expertise in the distribution of electronic components. Based in Hongkong, we have already established firm and mutual-benefit business relationships with customers from,Europe,America and south Asia,supplying obsolete and hard-to-find components to meet their specific needs.

With the principle of “Quality Parts,Customers Priority,Honest Operation,and Considerate Service”,our business mainly focus on the distribution of electronic components. Line cards we deal with include Microchip,ALPS,ROHM,Xilinx,Pulse,ON,Everlight and Freescale. Main products comprise IC,Modules,Potentiometer,IC Socket,Relay,Connector.Our parts cover such applications as commercial,industrial, and automotives areas.

We are looking forward to setting up business relationship with you and hope to provide you with the best service and solution. Let us make a better world for our industry!



Contact us

Tel: +86-755-8981 8866 Fax: +86-755-8427 6832

Email & Skype: info@chipsmall.com Web: www.chipsmall.com

Address: A1208, Overseas Decoration Building, #122 Zhenhua RD., Futian, Shenzhen, China



LOC		DIST		REVISIONS			
AD	00	REV	DATE	BY	CHK	APPV	
A		REV PER EC 0512-0302-05	15DEC05	BC	GS		
B		ECR-10-018652	10SEP10	SW	MQW		
C		ECO-11-024491	13DEC11	SY	MQW		

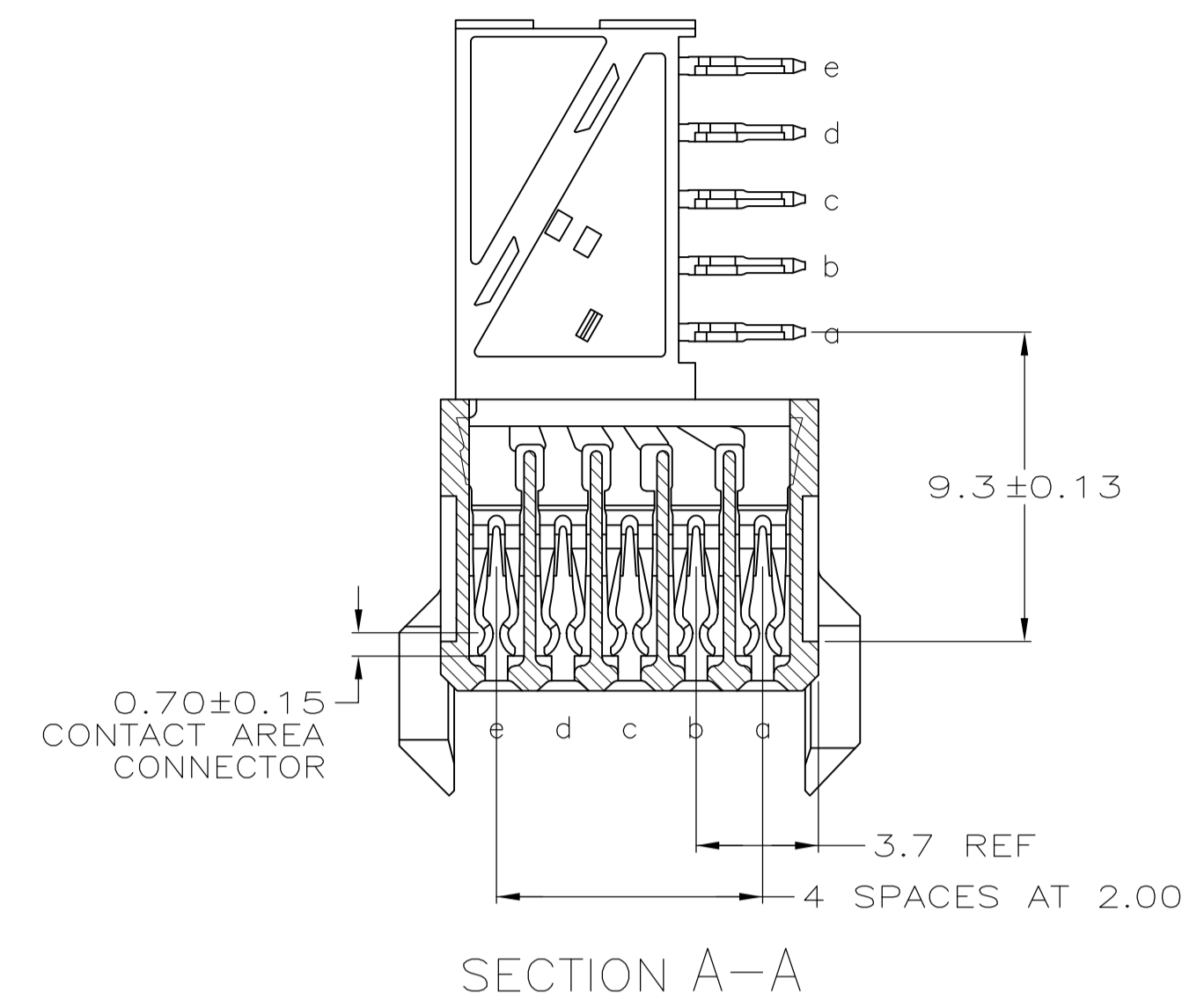
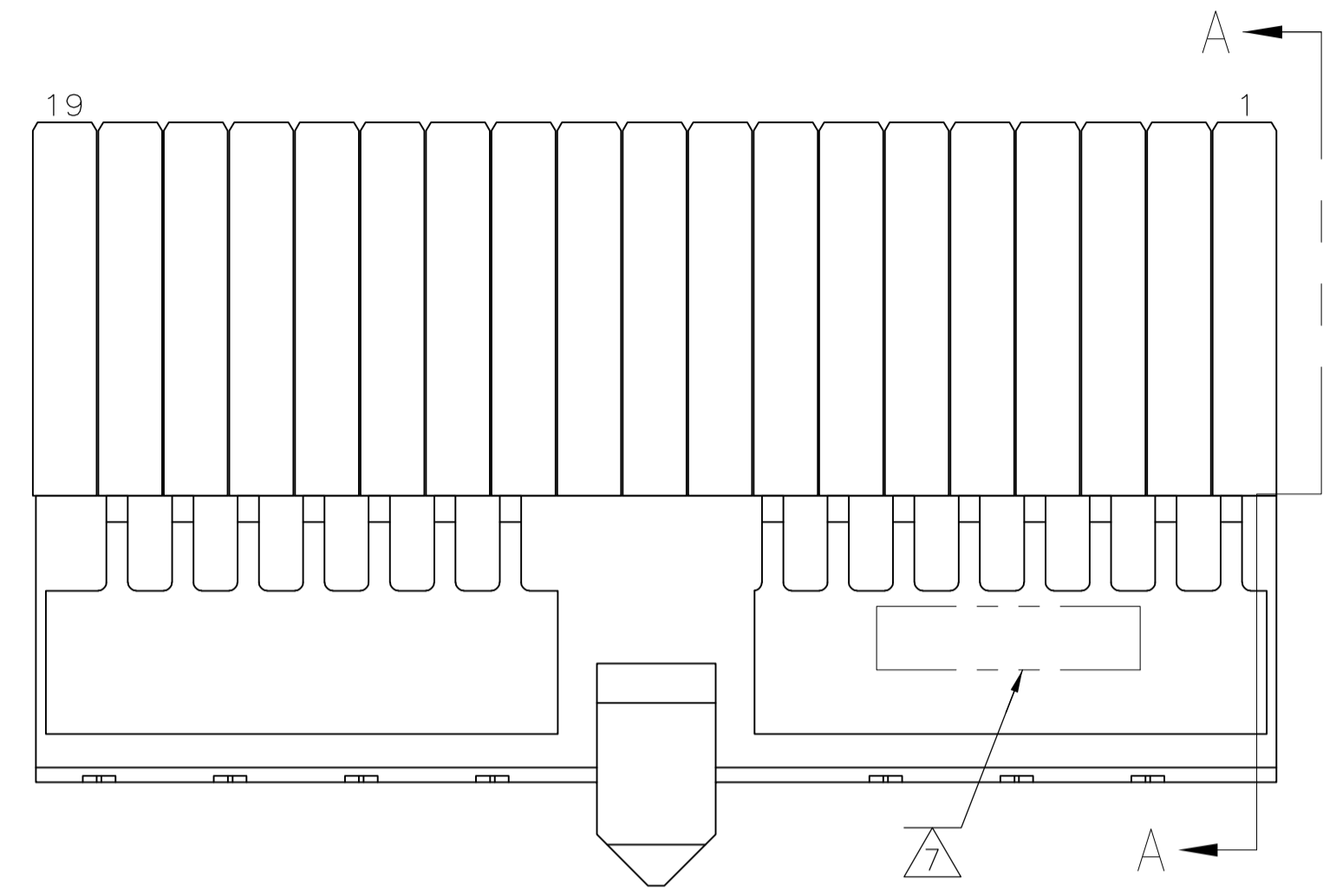

- 1 MATERIAL:
CONTACT: PHOSPHOR BRONZE.
HOUSING: GLASS-FILLED POLYESTER.
- 2 GENERAL PLATING SPECIFICATION: UNDERPLATING
(ENTIRE CONTACT): 1.27µm MIN NICKEL AND ACTION
PIN: 0.5µm MIN TIN.
FOR PLATING OF MATING SURFACES SEE APPLICABLE SPECIFICATION REFERENCE FOR EACH DASH NUMBER.
- 3 CONFORMS TO ALL TESTING ACCORDING TO IEC 61076-4-101 PERFORMANCE LEVEL 2.
- 4 CONFORMS TO ALL TESTING ACCORDING TO IEC 61076-4-101 PERFORMANCE LEVEL 1.
- 5 CONNECTOR TESTED AND QUALIFIED AGAINST TELCORDIA GR-1217-CORE QUALITY LEVEL 3, CENTRAL OFFICE APPLICATIONS.
- 6 CONNECTOR TESTED AND QUALIFIED AGAINST TELCORDIA GR-1217-CORE QUALITY LEVEL 3, UNCONTROLLED ENVIROMENT APPLICATIONS.
- 7 CONNECTOR MARKED WITH PART NUMBER AND DATE CODE. ADDITIONAL CHARACTERS OR MARKINGS, AS WELL AS THE LOCATION OF THE MARKINGS, MAY BE ADDED FOR TRACEABILITY BASED UPON MANUFACTURERS DISCRETION.
- 8 PLATED-THROUGH HOLES AT 2x2mm SQUARE GRID.
- 9 CONNECTOR LUBRICATED WITH BELCORE APPROVED LUBRICANT, TECHNICAL REFERENCE: TR-NWT-001217 ISSUE 1, SEP 1992.

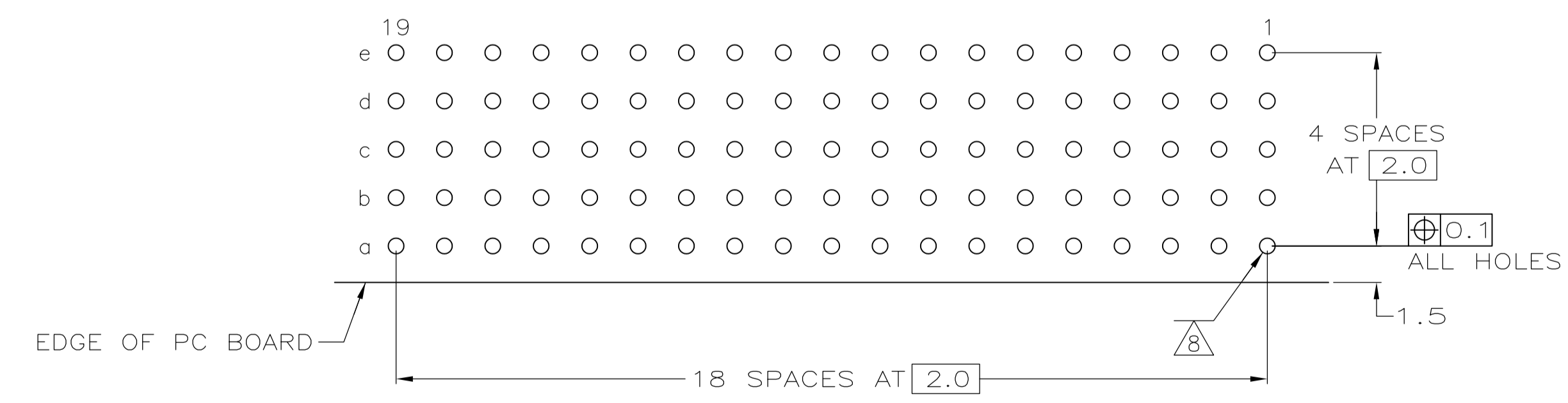
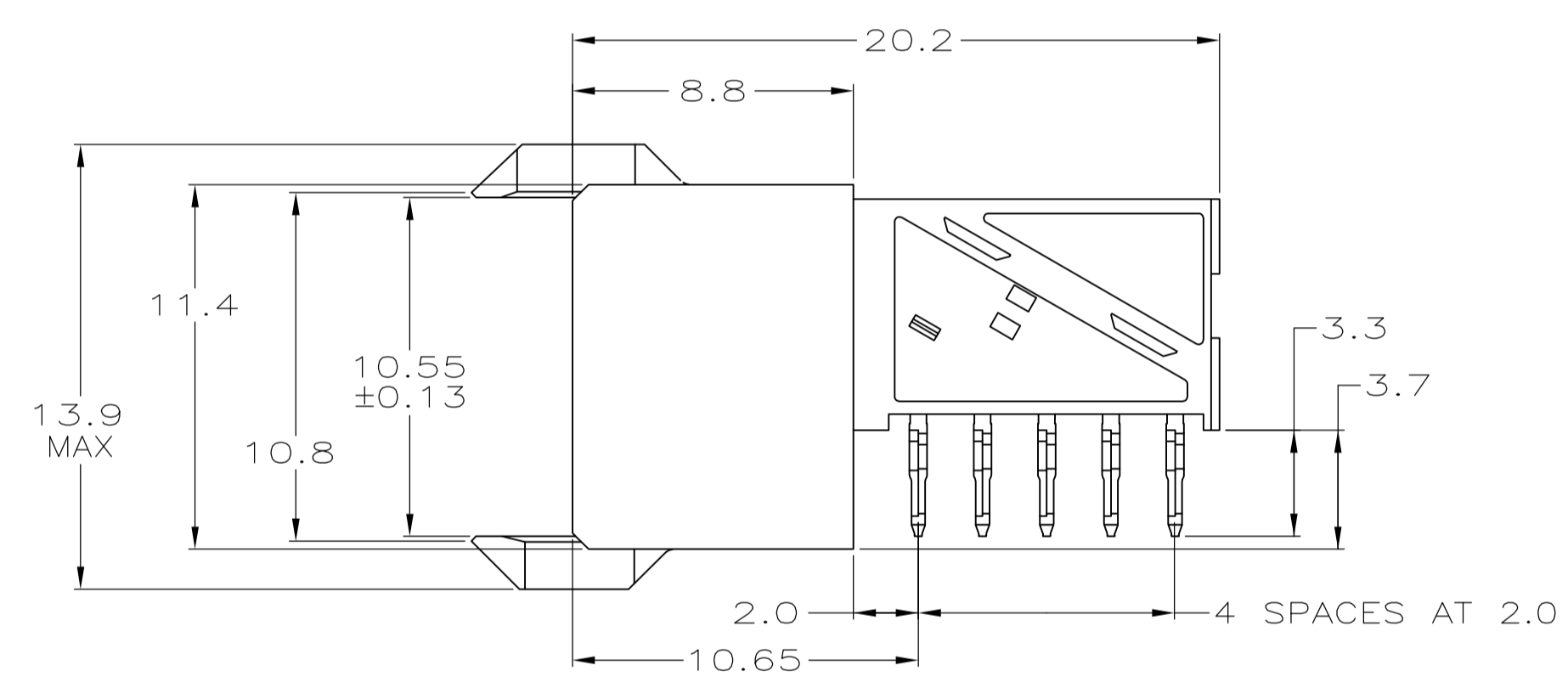
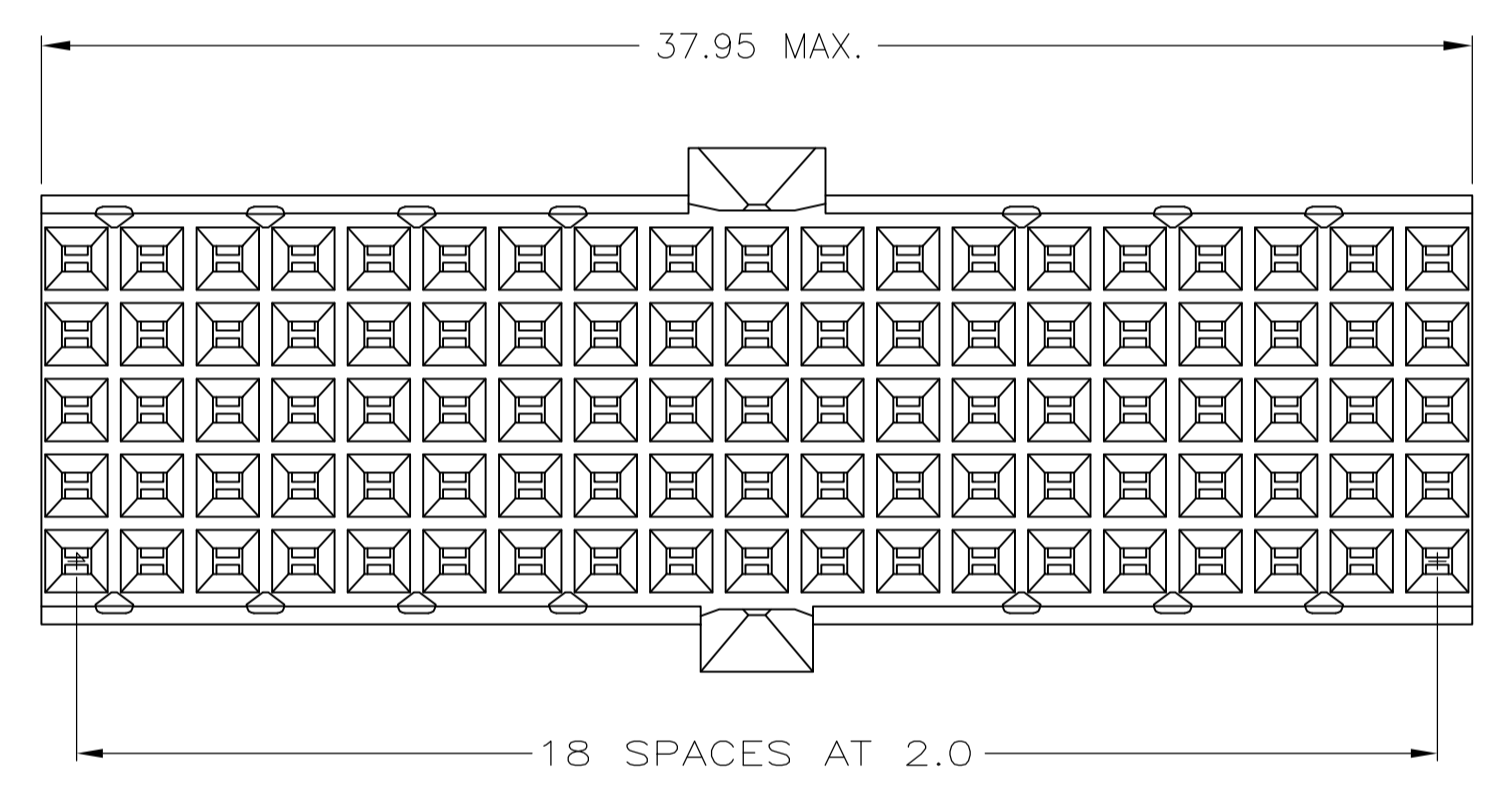

COMPONENT SIDE AS SHOWN
RECOMMENDED PCB HOLE LAYOUT

PLATED THRU HOLES PARAMETERS
REFERENCE APPLICATION SPECIFICATION

2/5/9	1-5646572-9
2/4/9	5646572-9
2/4	5646572-4
2/3	5646572-1
FINISH	PART NUMBER

THIS DRAWING IS A CONTROLLED DOCUMENT.

DIMENSIONS: mm	TOLERANCES UNLESS OTHERWISE SPECIFIED:	DIN B CARBO 04AUG05	04AUG05	Tyco Electronics Corporation Harrisburg, PA 17105-3608
0-PLC ±	±0.2	CHK G SKIPPER	04AUG05	
MATERIAL	FINISH SEE TABLE	APPV G SKIPPER 04AUG05	NAME	RECEPTACLE ASSEMBLY, Z-PACK 2mm HM, TYPE A/B
		PRODUCT SPEC	108-19082	RESTRICTED TO
		APPLICATION SPEC	114-19029	SIZE CAGE CODE DRAWING NO
		WEIGHT	A1 00779 C=5646572	SCALE 5:1 SHEET 1 OF 1 REV C
		CUSTOMER DRAWING		