



Chipsmall Limited consists of a professional team with an average of over 10 year of expertise in the distribution of electronic components. Based in Hongkong, we have already established firm and mutual-benefit business relationships with customers from,Europe,America and south Asia,supplying obsolete and hard-to-find components to meet their specific needs.

With the principle of “Quality Parts,Customers Priority,Honest Operation,and Considerate Service”,our business mainly focus on the distribution of electronic components. Line cards we deal with include Microchip,ALPS,ROHM,Xilinx,Pulse,ON,Everlight and Freescale. Main products comprise IC,Modules,Potentiometer,IC Socket,Relay,Connector.Our parts cover such applications as commercial,industrial, and automotives areas.

We are looking forward to setting up business relationship with you and hope to provide you with the best service and solution. Let us make a better world for our industry!



## Contact us

Tel: +86-755-8981 8866 Fax: +86-755-8427 6832

Email & Skype: info@chipsmall.com Web: www.chipsmall.com

Address: A1208, Overseas Decoration Building, #122 Zhenhua RD., Futian, Shenzhen, China



THIS DRAWING IS UNPUBLISHED. RELEASED FOR PUBLICATION ,19 .  
 © COPYRIGHT 19 BY AMP INCORPORATED. ALL RIGHTS RESERVED.

LOC	DIST	REVISIONS			
P	LTR	DESCRIPTION	DATE	DWN	APVD
AA	20	B	OBSOLETE: -2 PER EC 0515-0321-02	21JAN03	DLD/RPM

1. THIS KIT SHIPPED NOT ASSEMBLED.

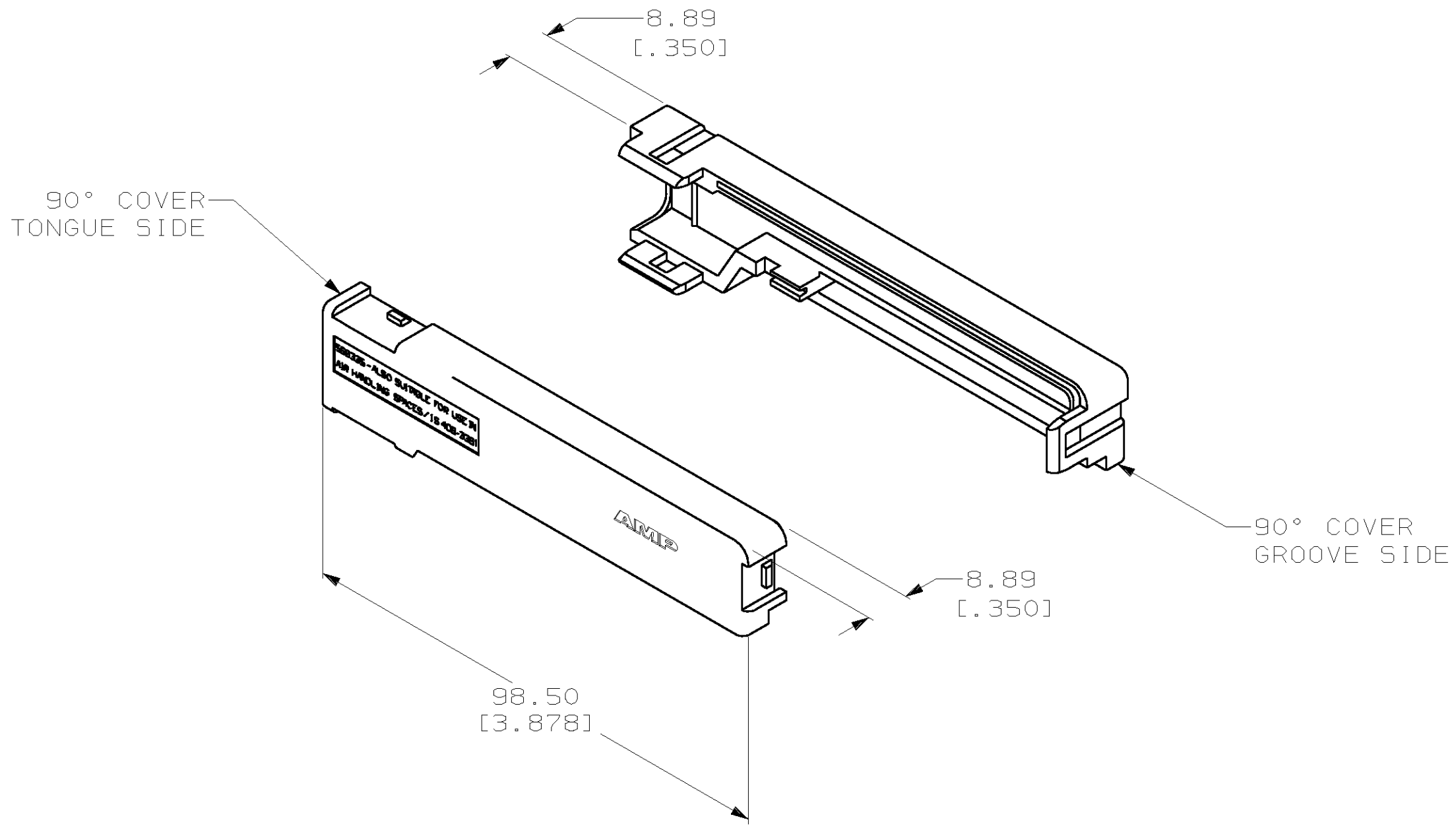

BLACK	569335-3
ALMOND	569335-1
COLOR	PART NUMBER

THIS DRAWING IS A CONTROLLED DOCUMENT FOR AMP INCORPORATED. IT IS SUBJECT TO CHANGE AND THE CONTROLLING ENGINEERING ORGANIZATION SHOULD BE CONTACTED FOR THE LATEST REVISION.		DWN DL DRUMMOND 5-09-95	AMP Incorporated Harrisburg, PA 17105-3608
DIMENSIONS: mm [INCHES]		CHK N. JONES 5-12-95	
TOLERANCES UNLESS OTHERWISE SPECIFIED:		APVD M. HUGHES 5-19-95	
0 PLC ±- 1 PLC ±- 2 PLC ±- 3 PLC ±0.13 [.005] 4 PLC ±- ANGLES ±-		NAME	
MATERIAL -	FINISH -	PRODUCT SPEC -	COVER KIT, 90 DEGREE, 50 POSITION, CHAMP SYSTEM 5
		APPLICATION SPEC -	SIZE A3
		WEIGHT -	CAGE CODE 00779
		CUSTOMER DRAWING	DRAWING NO C-569335
			SCALE 1:1
			SHEET 1 OF 1
			REV B