



Chipsmall Limited consists of a professional team with an average of over 10 year of expertise in the distribution of electronic components. Based in Hongkong, we have already established firm and mutual-benefit business relationships with customers from,Europe,America and south Asia,supplying obsolete and hard-to-find components to meet their specific needs.

With the principle of “Quality Parts,Customers Priority,Honest Operation,and Considerate Service”,our business mainly focus on the distribution of electronic components. Line cards we deal with include Microchip,ALPS,ROHM,Xilinx,Pulse,ON,Everlight and Freescale. Main products comprise IC,Modules,Potentiometer,IC Socket,Relay,Connector.Our parts cover such applications as commercial,industrial, and automotives areas.

We are looking forward to setting up business relationship with you and hope to provide you with the best service and solution. Let us make a better world for our industry!



Contact us

Tel: +86-755-8981 8866 Fax: +86-755-8427 6832

Email & Skype: info@chipsmall.com Web: www.chipsmall.com

Address: A1208, Overseas Decoration Building, #122 Zhenhua RD., Futian, Shenzhen, China



7.2 V Motor, Bracket and Wheel Kit (#570-00070)

Congratulations on purchasing the 7.2 V Motor, Bracket and Wheel Kit! This kit contains power, durability and simplicity all in one box. This kit features lightweight and sturdy aluminum brackets which are specifically designed to make mounting the included 7.2 Volt DC motors a breeze. Each bracket is machined in-house at Parallax headquarters in Rocklin, CA. The brackets are machined from 6063 aluminum extrusion and anodized black for improved scratch resistance aesthetic appeal.

High quality 7.2 Volt DC motors feature durable construction and 100% all-metal gears that stand up boldly to rough terrain and abuse. The motors' top speed of ~310 RPM equates to a speed of approximately 6.6 feet/second (2.0 m/s) which is perfect for most medium- to small- size robotic projects. The included machined aluminum hubs solidly engage the 4 7/8 inch (12.4 cm) diameter wheels. The tread is molded directly onto the wheel and offers excellent traction on most common surfaces.

Giving your robot mobility has never been easier!



Features

- Powerful 7.2 VDC brushed motors
- Motors use 100% all-metal gears
- Machined 6063 aluminum brackets anodized black for improved scratch & corrosion resistance
- Four convenient mounting holes for #8-size screws
- Durable 4 7/8 inch (12.4 cm) diameter wheels with high-traction tread
- Strong but light-weight construction
- Designed with the same mounting height as the Caster Wheel Kit (#28971, sold separately)
- Works well with the HB-25 (#29144) motor controllers

Specifications

- Motor ratings (at 7.2 VDC):
 - No-load current: 0.27 A @ 310 RPM
 - Stall current: 4.8 A
 - Max torque: 4.6 lb-in (5.3 kg-cm)
- Dimensions:
 - Wheels: 4 7/8 inch (12.4 cm) diameter x 0.8 inch (2.03 cm) wide
 - Mounting height: 3.86 inch (9.8 cm) from ground to mounting surface
 - Minimum clearance: 1.9 inch (4.8 cm) from ground to lowest point on motor
- Weight: 0.68 lbs. (1.45 kg) per wheel assembly (kit contains 2)
- Wheel tread: Thermoplastic rubber with a durometer rating of 50 Shore A

Bill of Materials

Part #	Description	Quantity
27950	Motor, 7.2 VDC, 310 RPM, 6 mm Shaft	2
710-00021	Screw, Zinc, Flat Head, Phil., 8 mm Length	6
721-00008	Wheel, 4 7/8 in. Diameter, Blue Tread	2
721-00009	Wheel Hub Assembly, 6mm Shaft I.D., (Hub, Set Screws, Retaining Rings)	2
725-00070	Motor Bracket , Aluminum, Anodized Black	2
725-00062	Hex Key 1/16 in.	1



Additional Tools Required (not included)

- # 1 Phillips Screw Driver
- Snap ring pliers
- Four 8-32 screws of the length for mounting to your platform
- Eye protection

Assembly Instructions

Step 1:

Using three flat-head screws connect each motor to a bracket as shown in drawing. A small amount of the blue Loctite can be used on the screw threads if desired.

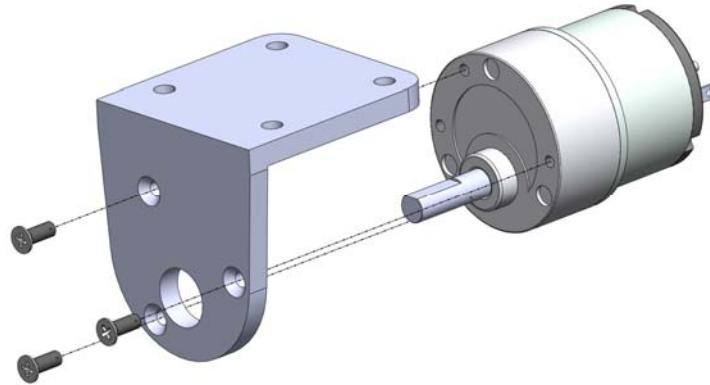

Step 2:

Place a hub onto each motor shaft, making sure the set screw holes line up with flat area on the shaft.

Using the hex key provided, insert the set screws into the holes in each hub and tighten until snug against motor shaft.

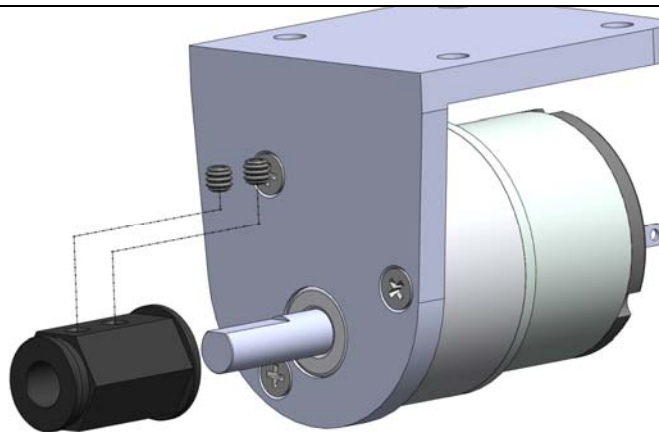

Step 3:

Safety Warning!

During or after installation, the retaining ring could fly off at high velocity if not installed properly. These dangers are minimized by wearing safety glasses during assembly and using the right tools for the job.

Install a wheel onto each hub. While wearing safety glasses, use snap ring pliers to install a retaining ring around the groove in the outer part of each hub.

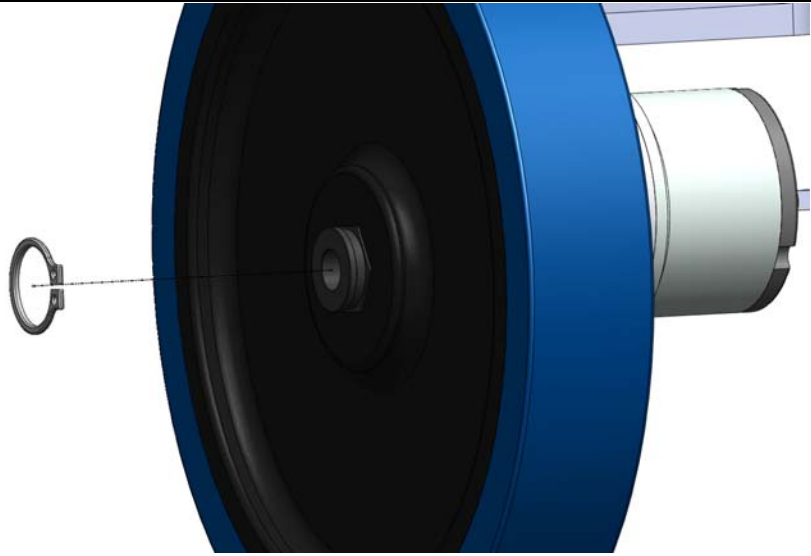

Material: Not Specified

NOTES

1. Dimensions are given for reference only and are subject to change without notice.

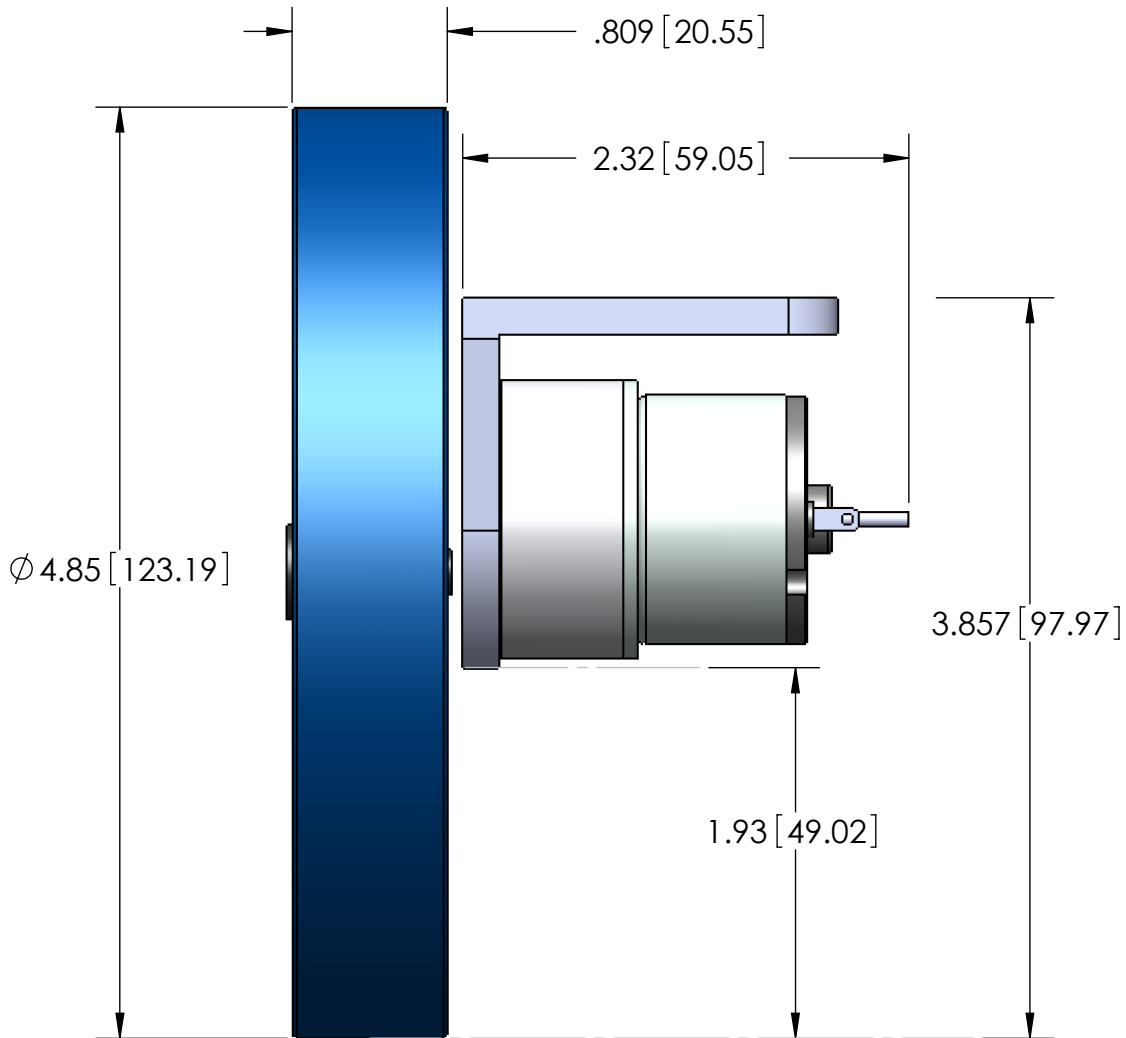

PROPRIETARY INFORMATION

THE INFORMATION CONTAINED IN THIS DRAWING IS THE SOLE PROPERTY OF PARALLAX, INC. ANY REPRODUCTION IN PART OR IN WHOLE WITHOUT THE WRITTEN PERMISSION OF PARALLAX, INC. IS PROHIBITED.

UNLESS OTHERWISE SPECIFIED

DIMENSIONS ARE IN INCHES (mm)
LENGTH TOLERANCES:
X.XX ± 0.010 IN
X.XXX ± 0.005 IN
ANGLE TOLERANCES:
X ± 5°
X.X ± 1°



599 MENLO DRIVE
ROCKLIN, CA 95765
www.PARALLAX.com
(916) 624-8333

DATE 20090725

Part # 570-00070

REV Rev A

Parent Part # ---

TITLE

Motor, Bracket & Wheel Kit Assembly

SCALE: 1:2

DRAWN BY Matt Huntzinger

SHEET 1 OF 1

Material: 6063 Aluminum-Anodized black

NOTES

1. Part is semmetrical across vertical center lines, excluding circular hole pattern.
2. Dimensions are given for reference only and are subject to change without notice.

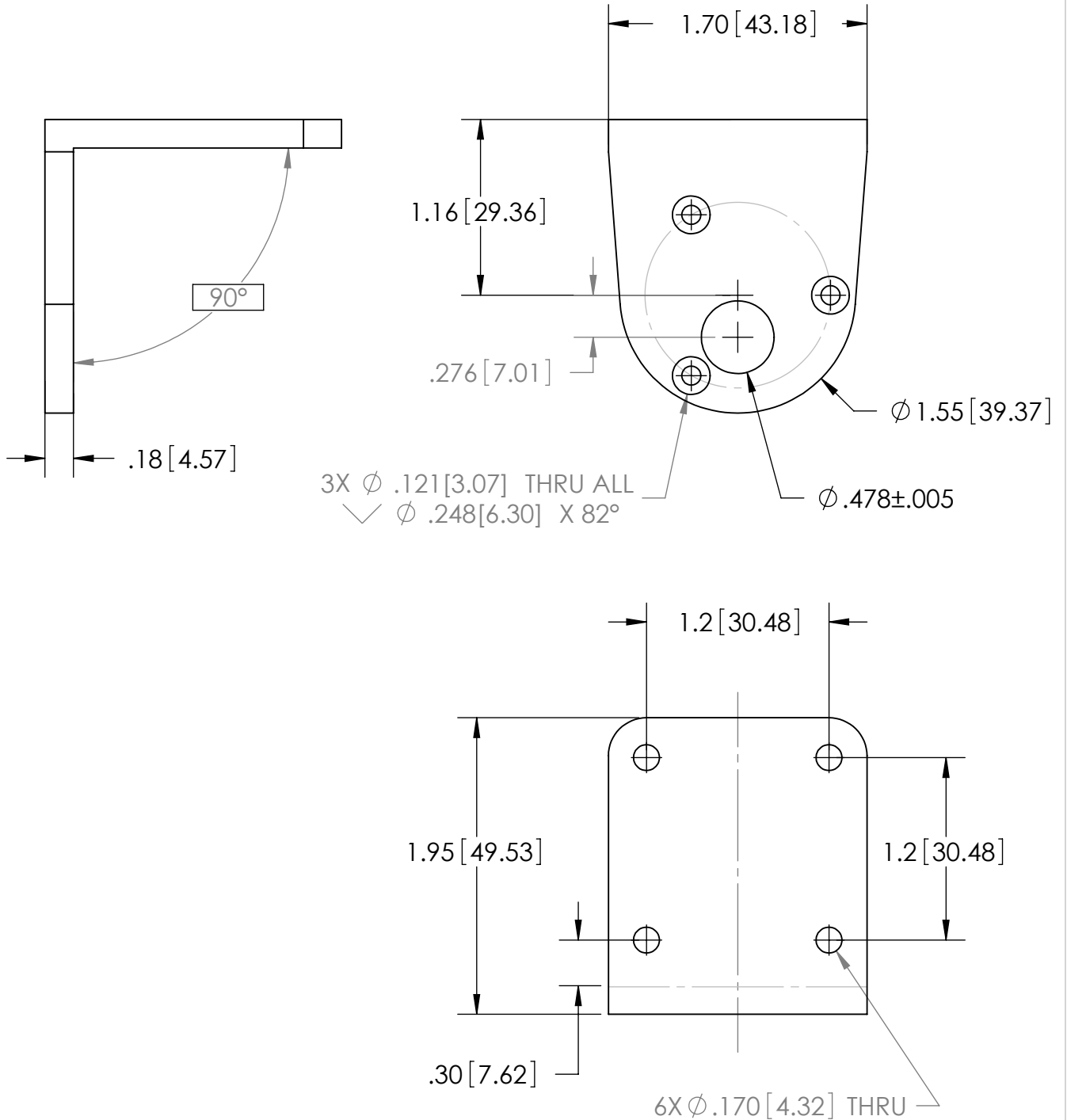

PROPRIETARY INFORMATION

THE INFORMATION CONTAINED IN THIS DRAWING IS THE SOLE PROPERTY OF PARALLAX, INC. ANY REPRODUCTION IN PART OR IN WHOLE WITHOUT THE WRITTEN PERMISSION OF PARALLAX, INC. IS PROHIBITED.

UNLESS OTHERWISE SPECIFIED

DIMENSIONS ARE IN INCHES (mm)
 LENGTH TOLERANCES:
 X.XX ± 0.010 IN
 X.XXX ± 0.005 IN
 ANGLE TOLERANCES:
 X $\pm 5^\circ$
 X.X $\pm 1^\circ$



599 MENLO DRIVE
 ROCKLIN, CA 95765
 www.PARALLAX.com
 (916) 624-8333

DATE 20090616

Part # 725-00070 REV A

Parent Part # 570-00070

TITLE

Motor Bracket

SCALE: 1:1

DRAWN BY M. Huntzinger

SHEET 1 OF 1