



Chipsmall Limited consists of a professional team with an average of over 10 year of expertise in the distribution of electronic components. Based in Hongkong, we have already established firm and mutual-benefit business relationships with customers from,Europe,America and south Asia,supplying obsolete and hard-to-find components to meet their specific needs.

With the principle of “Quality Parts,Customers Priority,Honest Operation,and Considerate Service”,our business mainly focus on the distribution of electronic components. Line cards we deal with include Microchip,ALPS,ROHM,Xilinx,Pulse,ON,Everlight and Freescale. Main products comprise IC,Modules,Potentiometer,IC Socket,Relay,Connector.Our parts cover such applications as commercial,industrial, and automotives areas.

We are looking forward to setting up business relationship with you and hope to provide you with the best service and solution. Let us make a better world for our industry!



Contact us

Tel: +86-755-8981 8866 Fax: +86-755-8427 6832

Email & Skype: info@chipsmall.com Web: www.chipsmall.com

Address: A1208, Overseas Decoration Building, #122 Zhenhua RD., Futian, Shenzhen, China





BOARD LEVEL COOLING – Slide On 5741

Slide On 5741 is a series of slide on board level heat sinks designed to cool TO-220 devices. Representative image only.



ORDERING INFORMATION

Part Number	Device Type
574102B00000G	TO-220
574102B03300G	TO-220
574102B03700G	TO-220

HEAT SINK DETAILS

Property	Details
Material	Aluminum
Finish	Black Anodize
Device Attachment Options	Spring Action Slide On
Thermal Interface Material	-

Property	Details
Heat Sink Width (mm)	19.05
Heat Sink Length (mm)	9.02
Heat Sink Height (mm)	21.84
Heat Sink Mounting Direction	Horizontal, Vertical

MECHANICAL & PERFORMANCE

Drawing dimensions are shown in mm, (in)

Part Number	"X" Dim	"Y" Dim	"Z" Dim
574102B00000G	-	-	-
574102B03300G	10.54 (0.415)	4.06 (0.160)	1.91 (0.075)
574102B03700G	10.54 (0.415)	4.06 (0.160)	1.91 (0.075)

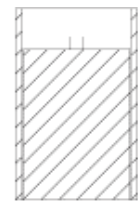
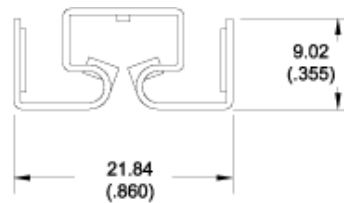

Mounting Details:

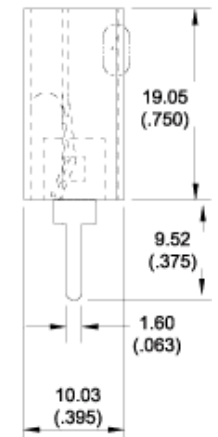
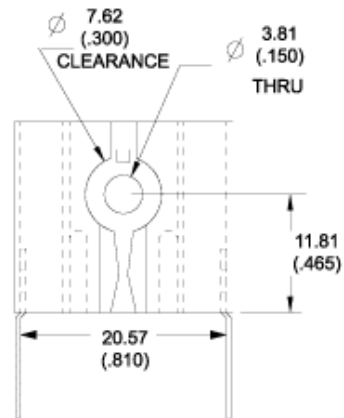
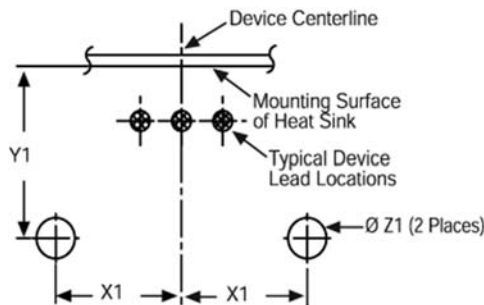

Board Level Cooling – Slide On 5741

