



Chipsmall Limited consists of a professional team with an average of over 10 year of expertise in the distribution of electronic components. Based in Hongkong, we have already established firm and mutual-benefit business relationships with customers from,Europe,America and south Asia,supplying obsolete and hard-to-find components to meet their specific needs.

With the principle of “Quality Parts,Customers Priority,Honest Operation,and Considerate Service”,our business mainly focus on the distribution of electronic components. Line cards we deal with include Microchip,ALPS,ROHM,Xilinx,Pulse,ON,Everlight and Freescale. Main products comprise IC,Modules,Potentiometer,IC Socket,Relay,Connector.Our parts cover such applications as commercial,industrial, and automotives areas.

We are looking forward to setting up business relationship with you and hope to provide you with the best service and solution. Let us make a better world for our industry!



## Contact us

Tel: +86-755-8981 8866 Fax: +86-755-8427 6832

Email & Skype: info@chipsmall.com Web: www.chipsmall.com

Address: A1208, Overseas Decoration Building, #122 Zhenhua RD., Futian, Shenzhen, China



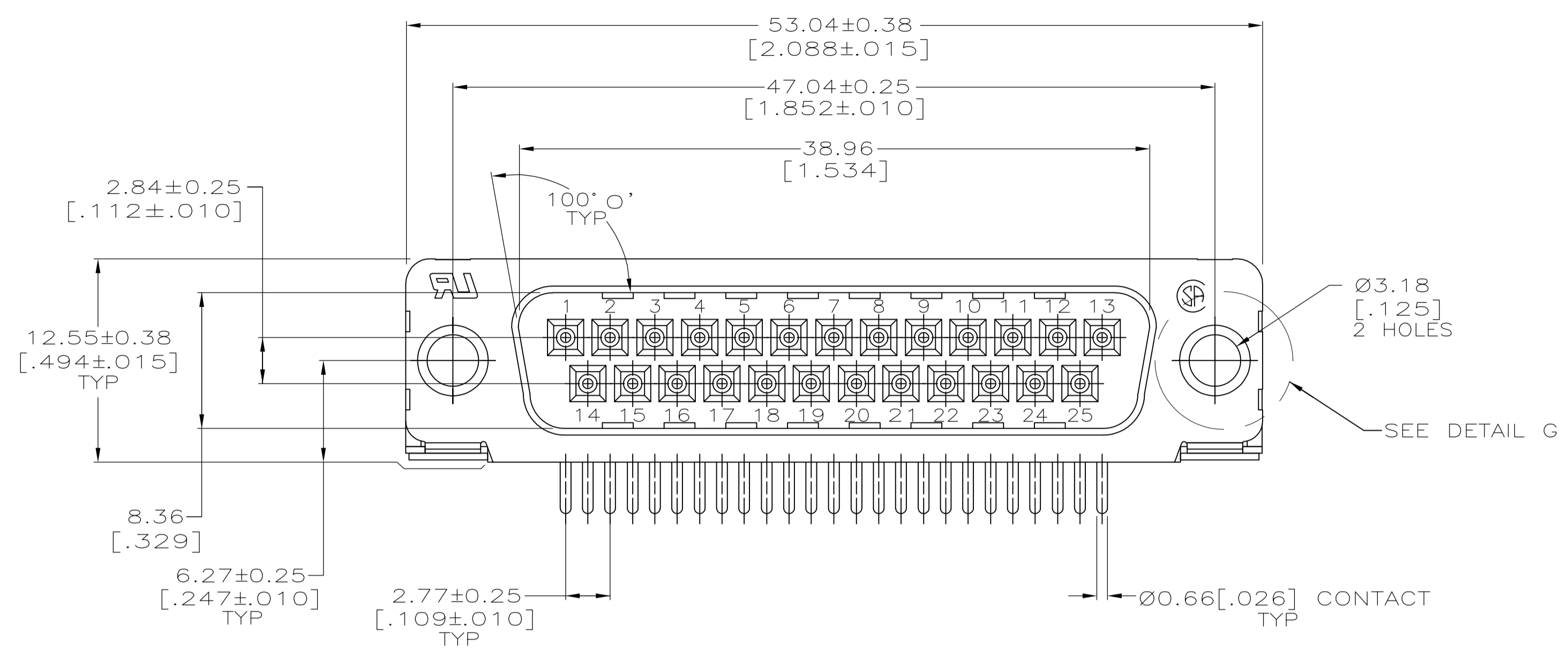

- 1 HOUSING: NYLON OR POLYESTER, FLAME RETARDANT, UL 94V-0 RATED, GLASS FILLED, BLACK.  
CONTACTS: BRASS  
SHELL: CARBON STEEL  
EYELETS: BRASS  
SCREWLOCKS AND INSERTS: ZINC
- 2 SHELL: 2.54µm [.000100] MIN TIN OVER 1.27µm [.000050] MIN COPPER.  
CONTACTS: SEE TABLE  
EYELETS: 2.54µm [.000100] MIN TIN OVER COPPER FLASH.  
SCREWLOCKS & INSERTS: CLEAR CHROMATE
- 3 GOLD FLASH ON THE MATING SURFACES, 2.54µm (.000100) MIN TIN PLATE ON THE SOLDER END, 1.27µm (.000050) MIN NICKEL UNDERPLATE ON THE ENTIRE CONTACT.
- 4 0.76µm (.000030) MIN GOLD PLATE ON THE MATING SURFACES, 2.54µm (.000100) MIN TIN PLATE ON THE SOLDER END, 1.27µm (.000050) MIN NICKEL UNDERPLATE ON THE ENTIRE CONTACT  
-OR-  
GOLD FLASH OVER PALLADIUM-NICKEL PLATE, 0.76µm (.000030) MIN TOTAL ON THE MATING SURFACES, 2.54µm (.000100) MIN TIN PLATE ON THE SOLDER END, 1.27µm (.000050) MIN NICKEL UNDERPLATE ON THE ENTIRE CONTACT.

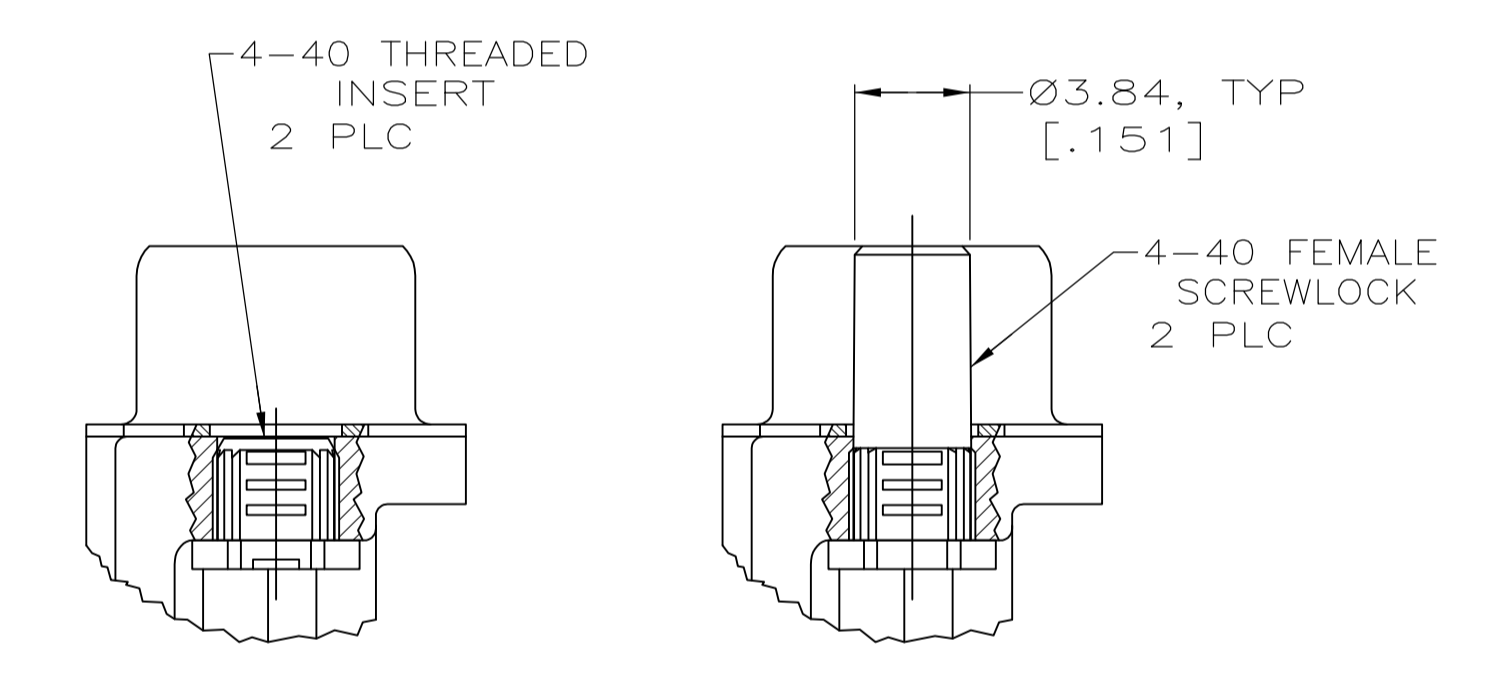
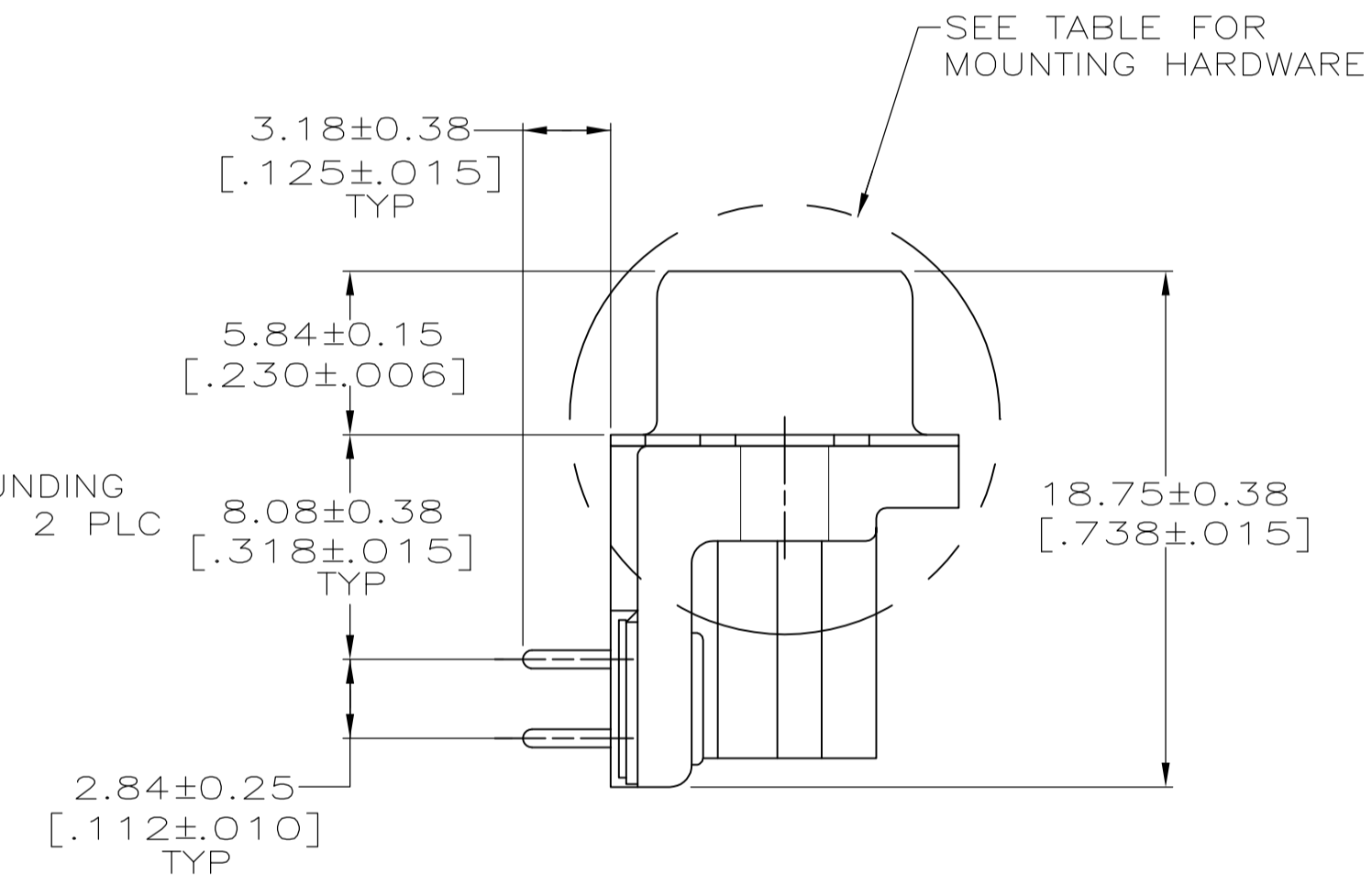
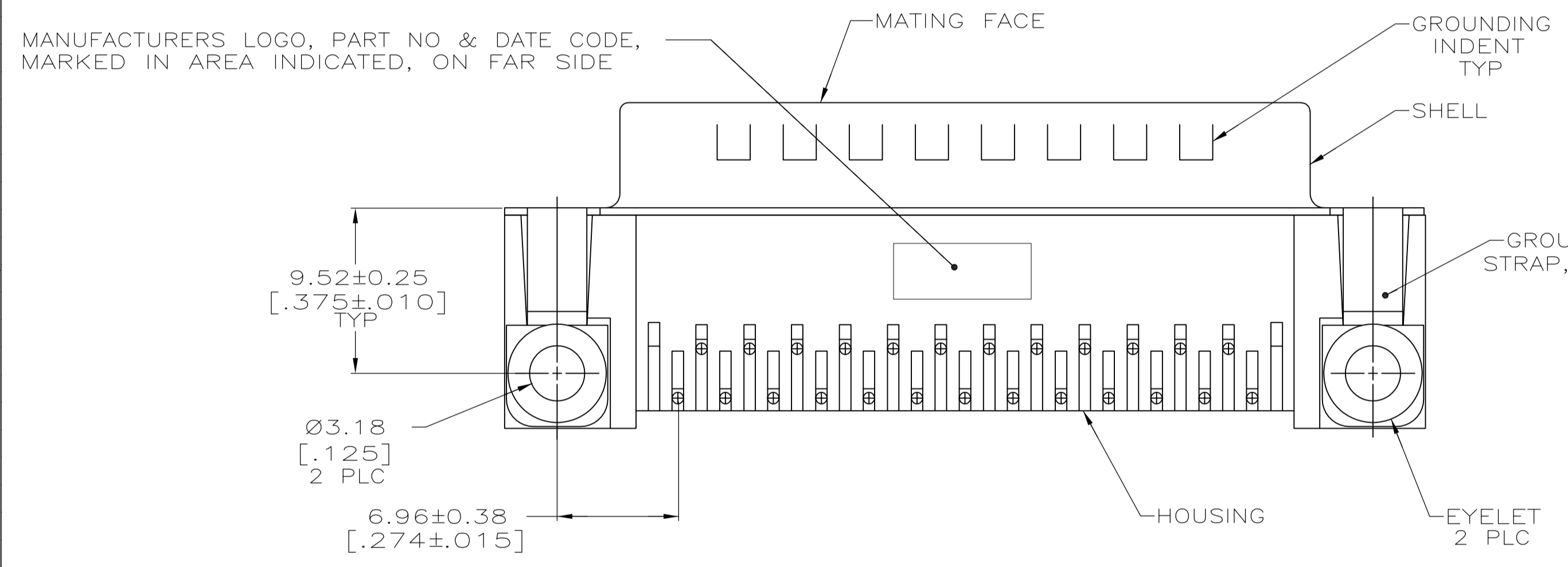

DETAIL D      DETAIL E

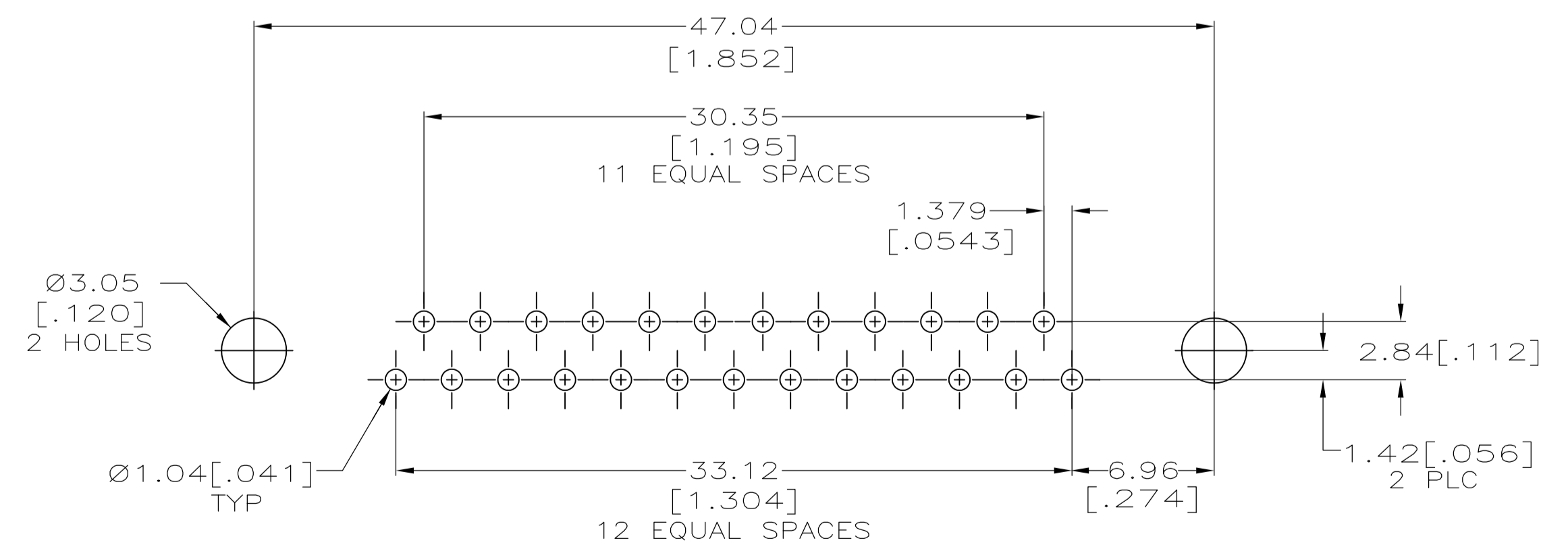

RECOMMENDED P.C. BOARD MOUNTING DIMENSIONS

SEE DETAIL E	△	5747238-6
SEE DETAIL D	△	5747238-4
-	△	5747238-3
-	△	5747238-2
OBSOLETE	△	5747238-1
MOUNTING HARDWARE	CONTACT FINISH	PART NUMBER

THIS DRAWING IS A CONTROLLED DOCUMENT. DIMENSIONING AND TOLERANCING PER ASME Y14.5M-2009		DIN A FERNANDEZ-DOCKS 04-12-05 C/K S. BOLASH 04-12-05		APVD M. WALMSLEY 04-12-05		NAME		TE Connectivity	
DIMENSIONS: mm [INCHES]		TOLERANCES UNLESS OTHERWISE SPECIFIED:		PRODUCT SPEC		APPLICATION SPEC		PLUG ASSEMBLY, SIZE 3, 25 POSITION, RIGHT ANGLE, FRONT METAL SHELL, .318 SERIES, AMPLIMITE HD-20	
Ø		0 PLC ± -		108-40025		SIZE		DRAWING NO	
H		1 PLC ± -		114-40010		SCALE		RESTRICTED TO	
D		2 PLC ± -		WEIGHT		CUSTOMER DRAWING		REV D	
R		3 PLC ± 0.13(.005)		A1 00779		5747238		SHEET 1 OF 1	
A		4 PLC ± -		SCALE 4:1		SHEET 1 OF 1		REV D	
S		ANGLES ± 2°		SCALE 4:1		SHEET 1 OF 1		REV D	