



Chipsmall Limited consists of a professional team with an average of over 10 year of expertise in the distribution of electronic components. Based in Hongkong, we have already established firm and mutual-benefit business relationships with customers from,Europe,America and south Asia,supplying obsolete and hard-to-find components to meet their specific needs.

With the principle of “Quality Parts,Customers Priority,Honest Operation,and Considerate Service”,our business mainly focus on the distribution of electronic components. Line cards we deal with include Microchip,ALPS,ROHM,Xilinx,Pulse,ON,Everlight and Freescale. Main products comprise IC,Modules,Potentiometer,IC Socket,Relay,Connector.Our parts cover such applications as commercial,industrial, and automotives areas.

We are looking forward to setting up business relationship with you and hope to provide you with the best service and solution. Let us make a better world for our industry!



## Contact us

Tel: +86-755-8981 8866 Fax: +86-755-8427 6832

Email & Skype: info@chipsmall.com Web: www.chipsmall.com

Address: A1208, Overseas Decoration Building, #122 Zhenhua RD., Futian, Shenzhen, China





**BOARD LEVEL COOLING – Snap On 5780**

Snap On 5780 is a series of snap on board level heat sinks designed to cool TO-5 devices. Representative image only.

**ORDERING INFORMATION**

Part Number	Device Type
578105B00000G	TO-5
578205B00000G	TO-5
578305B00000G	TO-5
578405B00000G	TO-5



**HEAT SINK DETAILS**

Property	Details
Material	Aluminum
Finish	Black Anodize
Device Attachment Options	Snap On
Thermal Interface Material	-

Property	Details
Heat Sink Width (mm)	21.08
Heat Sink Length (mm)	10.03
Heat Sink Height (mm)	See Table Below
Heat Sink Mounting Direction	Vertical

**MECHANICAL & PERFORMANCE**

Drawing dimensions are shown in mm, (in)

Part Number	"A" Dim	Heat Sink Height
578105B00000G	3.96	10.31
578205B00000G	6.35	12.7
578305B00000G	12.70	19.05
578405B00000G	19.50	25.85

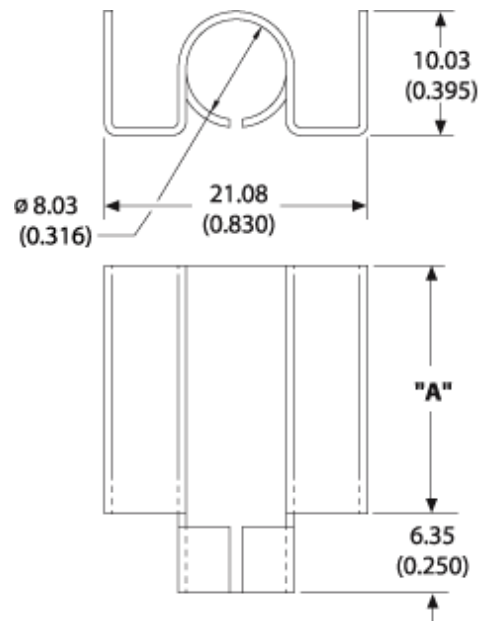

# Board Level Cooling – Snap On 5780

