



Chipsmall Limited consists of a professional team with an average of over 10 year of expertise in the distribution of electronic components. Based in Hongkong, we have already established firm and mutual-benefit business relationships with customers from,Europe,America and south Asia,supplying obsolete and hard-to-find components to meet their specific needs.

With the principle of “Quality Parts,Customers Priority,Honest Operation,and Considerate Service”,our business mainly focus on the distribution of electronic components. Line cards we deal with include Microchip,ALPS,ROHM,Xilinx,Pulse,ON,Everlight and Freescale. Main products comprise IC,Modules,Potentiometer,IC Socket,Relay,Connector.Our parts cover such applications as commercial,industrial, and automotives areas.

We are looking forward to setting up business relationship with you and hope to provide you with the best service and solution. Let us make a better world for our industry!



Contact us

Tel: +86-755-8981 8866 Fax: +86-755-8427 6832

Email & Skype: info@chipsmall.com Web: www.chipsmall.com

Address: A1208, Overseas Decoration Building, #122 Zhenhua RD., Futian, Shenzhen, China



LOC		DIST		REVISIONS			
GP	00	P	LTR	DESCRIPTION	DATE	DWN	APVD
C				REVISED PER ECO-12-022391	02JAN2013	CJV	SLB

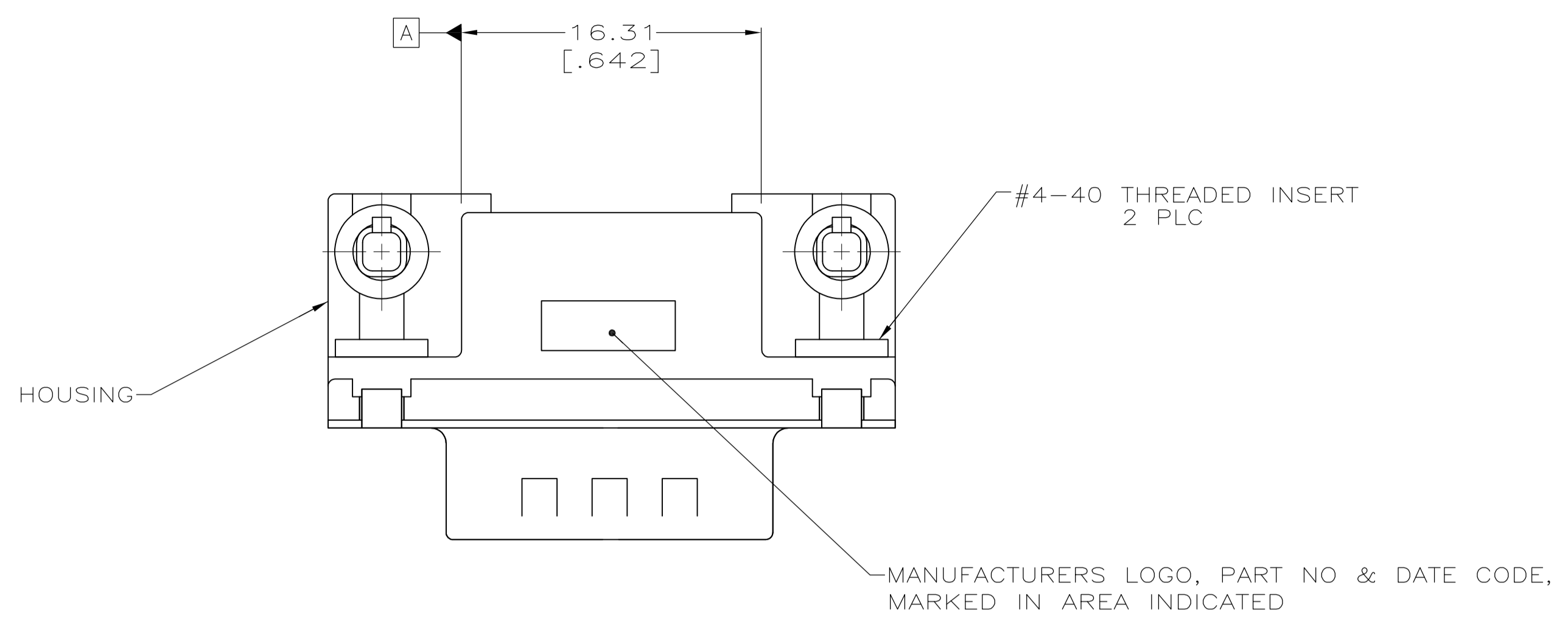

- 1 HOUSING: NYLON, UL 94VO RATED, BLACK.
SHELL: CARBON STEEL.
PIN CONTACTS: BRASS.
EYELETS: BRASS.
THREADED INSERTS: ZINC.
BOARDLOCKS: COPPER ALLOY.
- 2 PIN CONTACTS: 0.76μm[.000030] MIN GOLD PLATE ON THE MATING SURFACES, 2.54μm[.000100] MIN TIN PLATE ON THE SOLDER END, 1.27μm[.000050] MIN NICKEL UNDERPLATE ON THE ENTIRE CONTACT
-OR-
GOLD FLASH OVER PALLADIUM-NICKEL PLATE, 0.76μm[.000030] MIN TOTAL ON THE MATING SURFACES, 2.54μm[.000100] MIN TIN PLATE ON THE SOLDER END, 1.27μm[.000050] MIN NICKEL UNDERPLATE ON THE ENTIRE CONTACT.
EYELETS: 2.54μm[.000100] MIN TIN OVER COPPER FLASH.
SHELL: 2.54μm[.000100] MIN TIN OVER 1.27μm[.000050] MIN COPPER.
THREADED INSERTS: CLEAR CHROMATE.
BOARDLOCKS: 3.81μm[.000150] MIN TIN OVER 1.27μm[.000050] MIN NICKEL.
- 3 PIN CONTACTS: GOLD FLASH ON THE MATING SURFACES, 2.54μm[.000100] MIN TIN PLATE ON THE SOLDER END, 1.27μm[.000050] MIN NICKEL UNDERPLATE ON THE ENTIRE CONTACT.
EYELETS: 2.54μm[.000100] MIN TIN OVER COPPER FLASH.
SHELL: 2.54μm[.000100] MIN TIN OVER 1.27μm[.000050] MIN COPPER.
THREADED INSERTS: CLEAR CHROMATE.
BOARDLOCKS: 3.81μm[.000150] MIN TIN OVER 1.27μm[.000050] MIN NICKEL.
- 4 DATUMS AND BASIC DIMENSIONS ESTABLISHED BY CUSTOMER.
- 5 POSITION TOLERANCE APPLIES AT CONTACT TIP.
- 6 BOARDLOCKS WILL ACCEPT .062 MAX PRINTED CIRCUIT BOARD THICKNESS.
- 7. COMPATIBLE WITH REFLOW SOLDERING APPLICATIONS TO A MAXIMUM OF 225°C FOR A MAXIMUM DURATION OF 90 SECONDS. TEMPERATURE TO BE MEASURED ON CONNECTOR SURFACE.

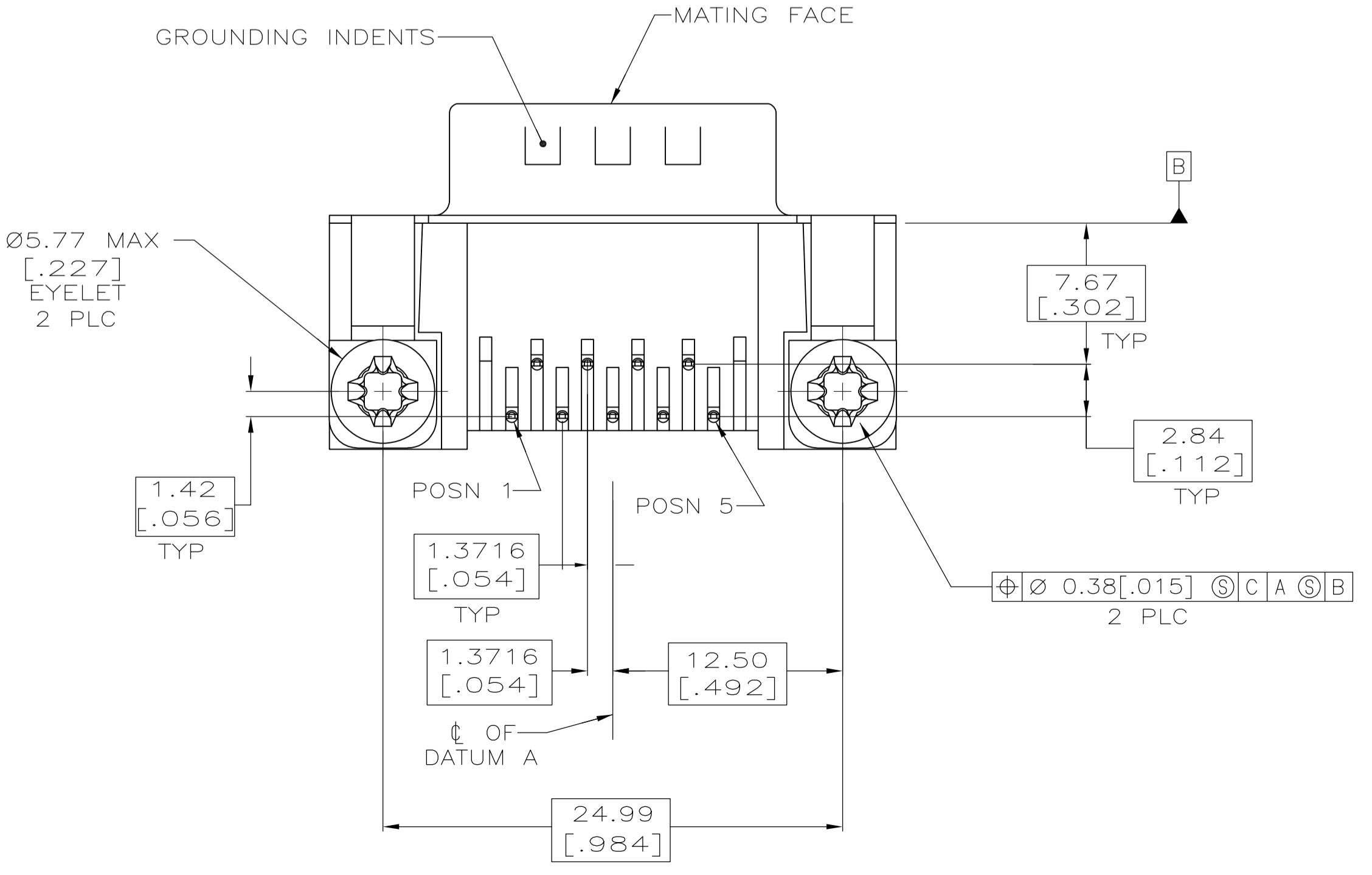
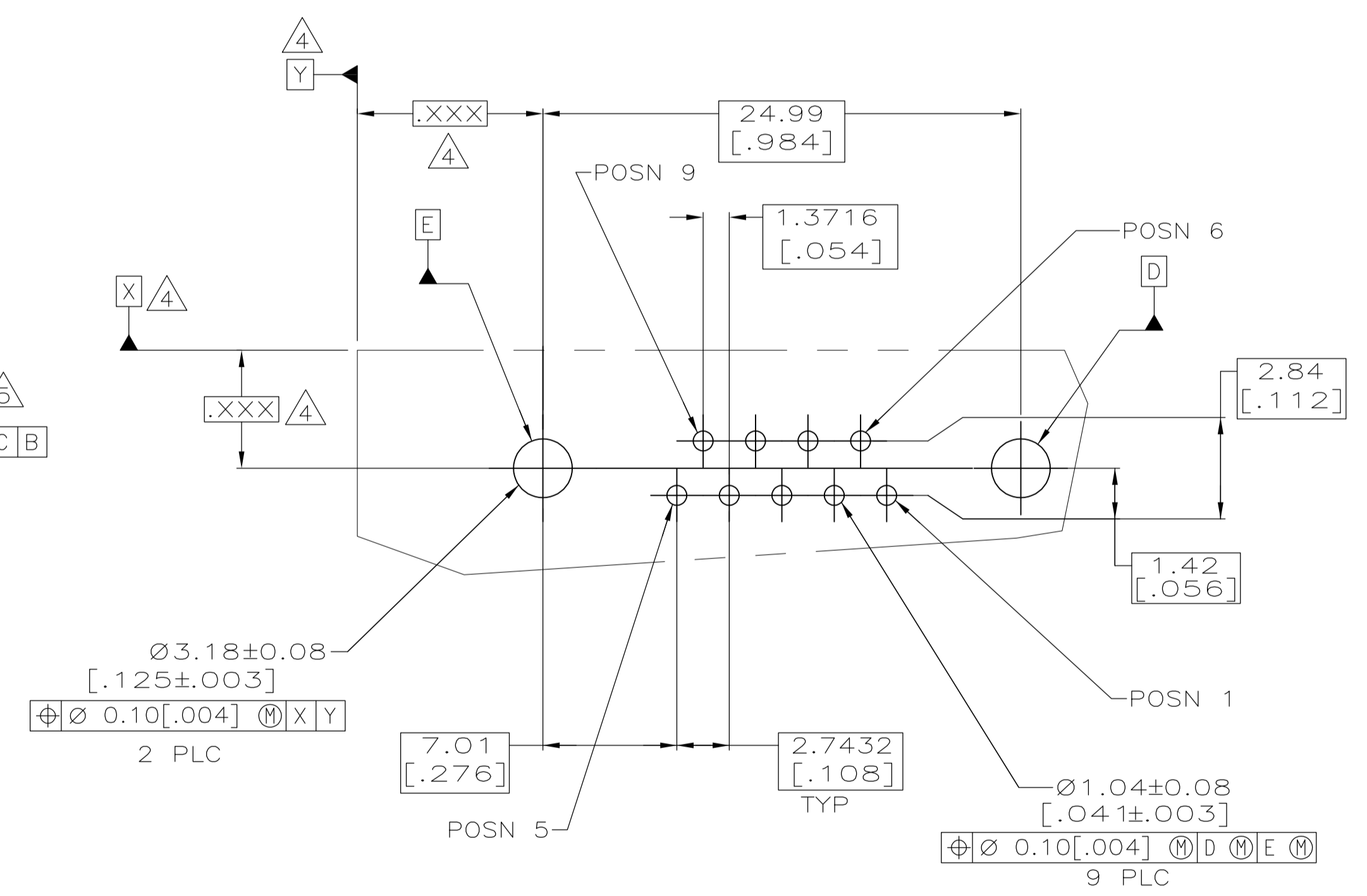
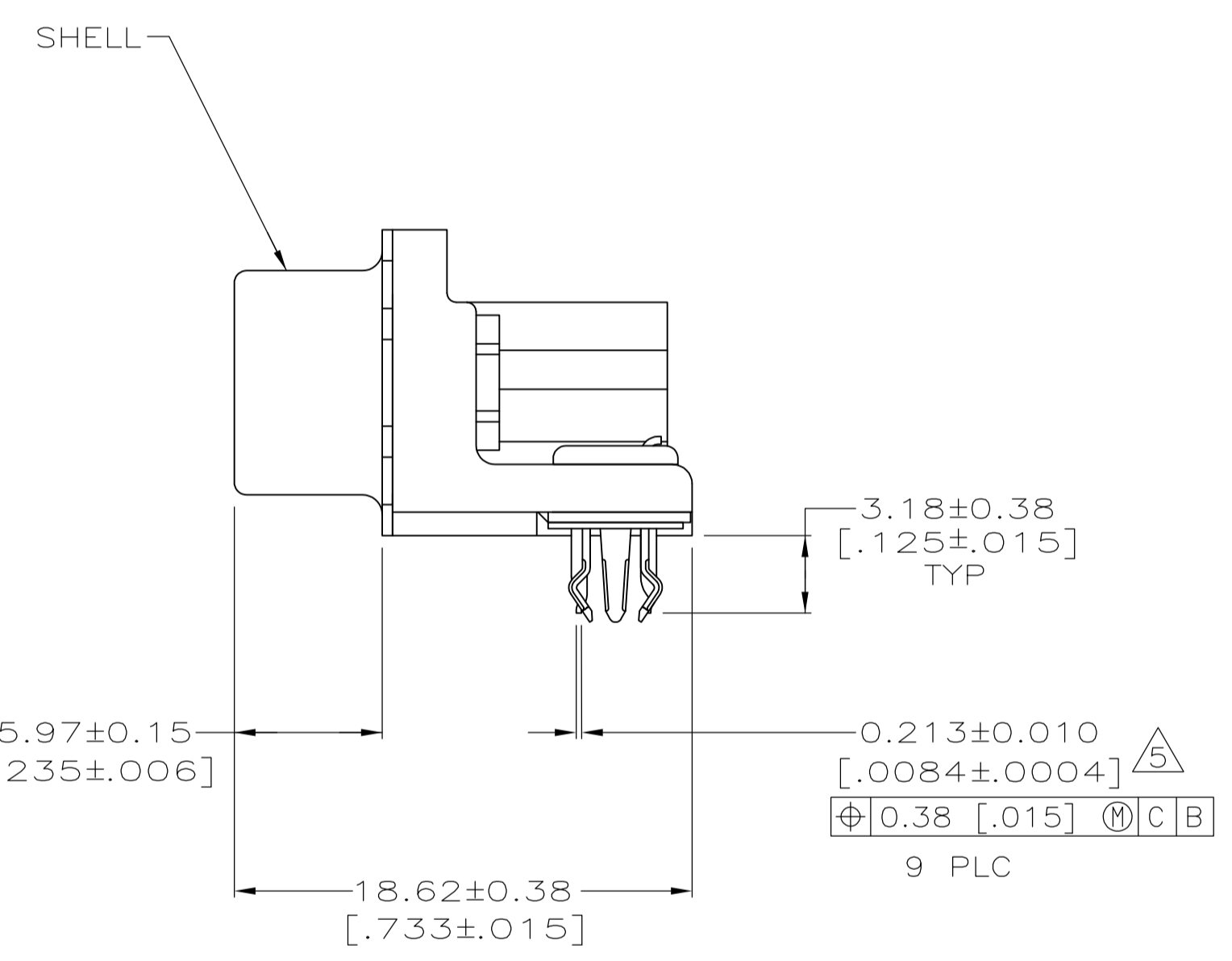
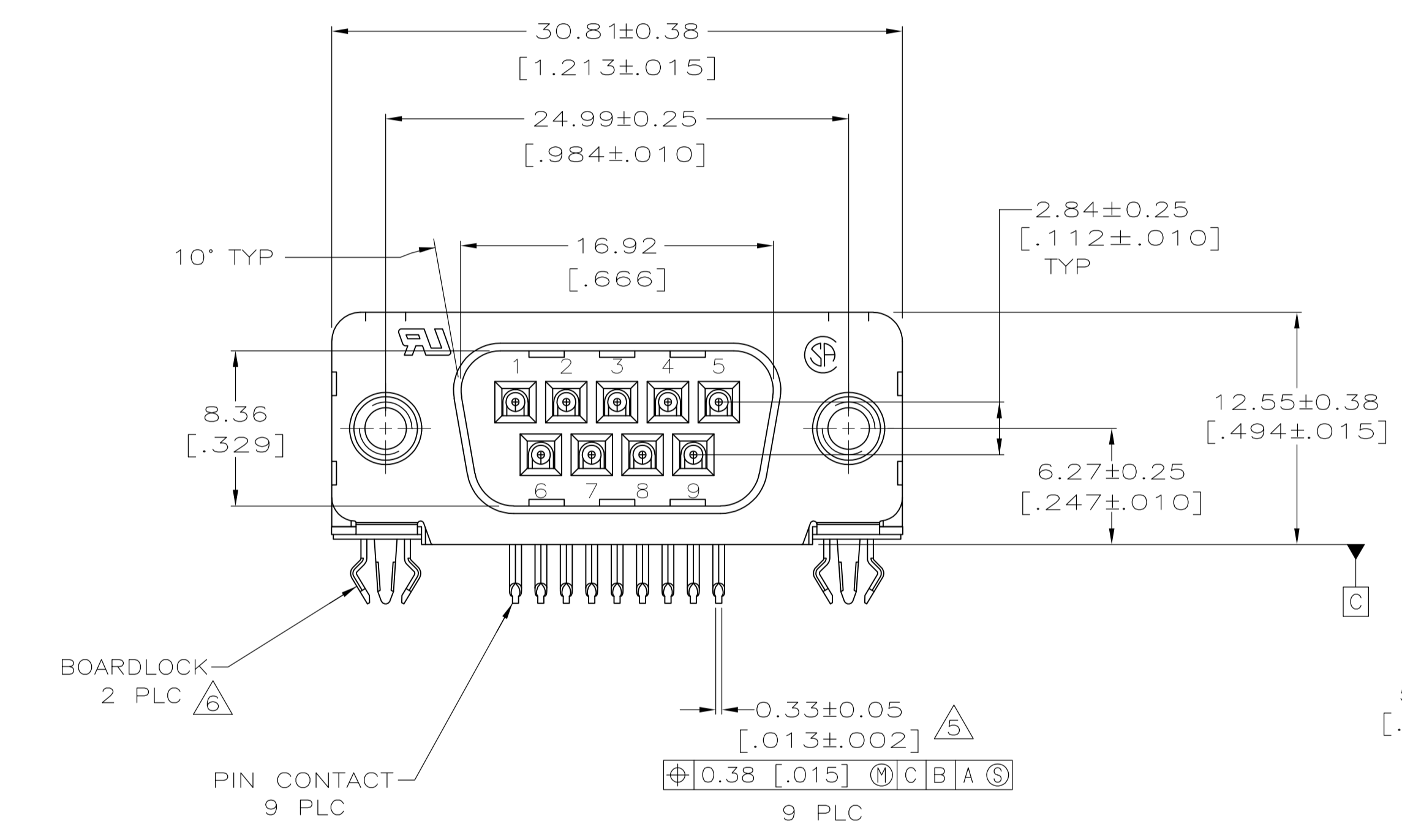

**COPYRIGHT 2005
TYCO ELECTRONICS CORP
ALL RIGHTS RESERVED**

THIS DRAWING IS A CONTROLLED DOCUMENT. DIMENSIONING AND TOLERANCING PER ASME Y14.5M-2009		DIN L VARELA - DOCKS 04-11-05		S BOLASH 04-11-05		M WALMSLEY 04-11-05		NAME	
DIMENSIONS: mm [INCHES]		TOLERANCES UNLESS OTHERWISE SPECIFIED:		PRODUCT SPEC		APPLICATION SPEC		PLUG ASSEMBLY, SIZE 1, .318 SERIES, WITH FRONT METAL SHELL, HIGH TEMPERATURE, AMPLIMITE HD-20	
0 PLC ± -		1 PLC ± -		2 PLC ± 0.13 [.005]		3 PLC ± -		108-40025	
4 PLC ± -		ANGLES ± ±		114-40010		SIZE		CAGE CODE DRAWING NO	
MATERIAL		FINISH		WEIGHT		A1 00779		RESTRICTED TO	
SEE TABLE		CUSTOMER DRAWING		SCALE 4:1		SHEET 1 OF 1		REV C	

3	5788792-2
2	5788792-1
FINISH	PART NO

