



Chipsmall Limited consists of a professional team with an average of over 10 year of expertise in the distribution of electronic components. Based in Hongkong, we have already established firm and mutual-benefit business relationships with customers from,Europe,America and south Asia,supplying obsolete and hard-to-find components to meet their specific needs.

With the principle of “Quality Parts,Customers Priority,Honest Operation,and Considerate Service”,our business mainly focus on the distribution of electronic components. Line cards we deal with include Microchip,ALPS,ROHM,Xilinx,Pulse,ON,Everlight and Freescale. Main products comprise IC,Modules,Potentiometer,IC Socket,Relay,Connector.Our parts cover such applications as commercial,industrial, and automotives areas.

We are looking forward to setting up business relationship with you and hope to provide you with the best service and solution. Let us make a better world for our industry!



## Contact us

Tel: +86-755-8981 8866 Fax: +86-755-8427 6832

Email & Skype: info@chipsmall.com Web: www.chipsmall.com

Address: A1208, Overseas Decoration Building, #122 Zhenhua RD., Futian, Shenzhen, China



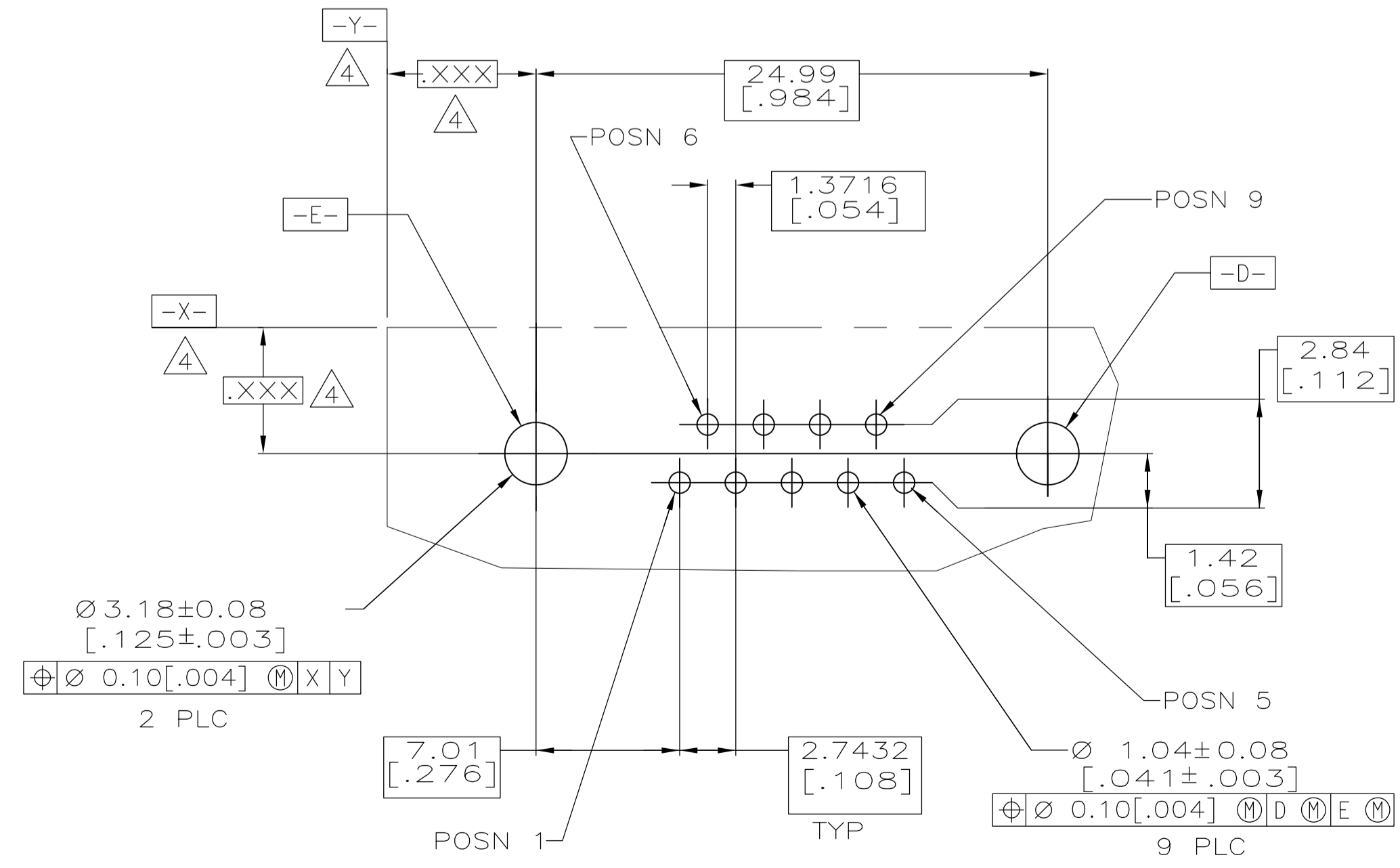
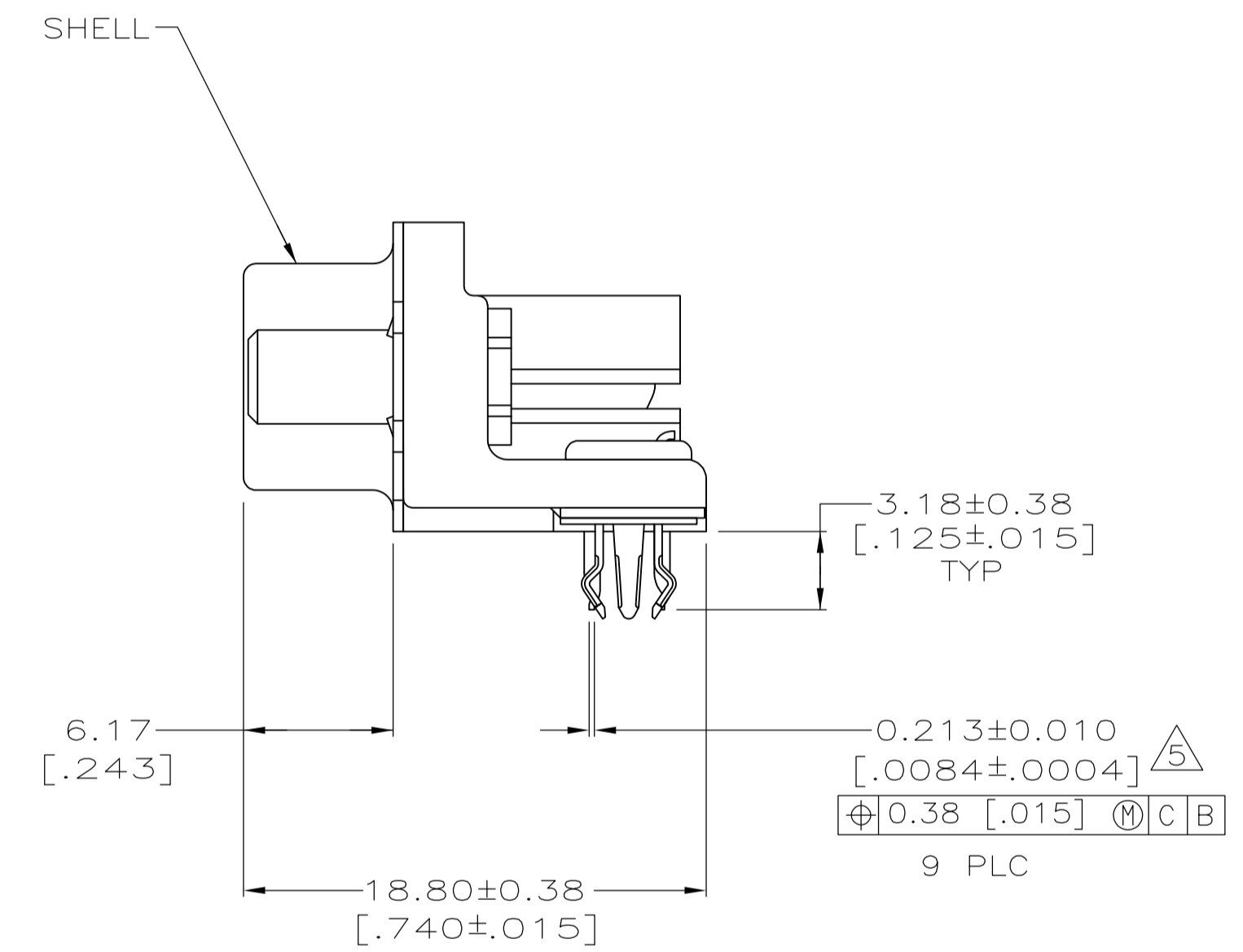
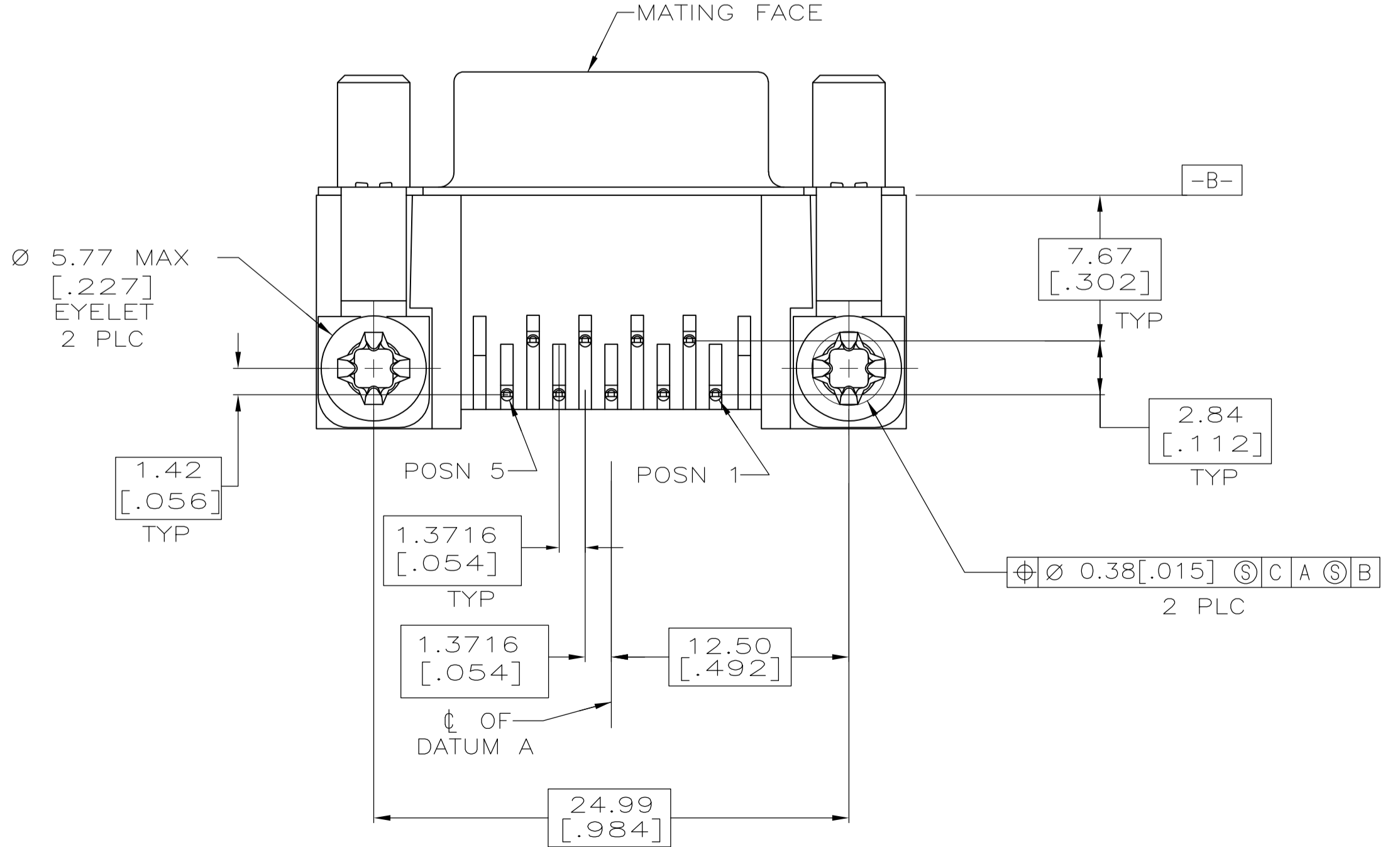
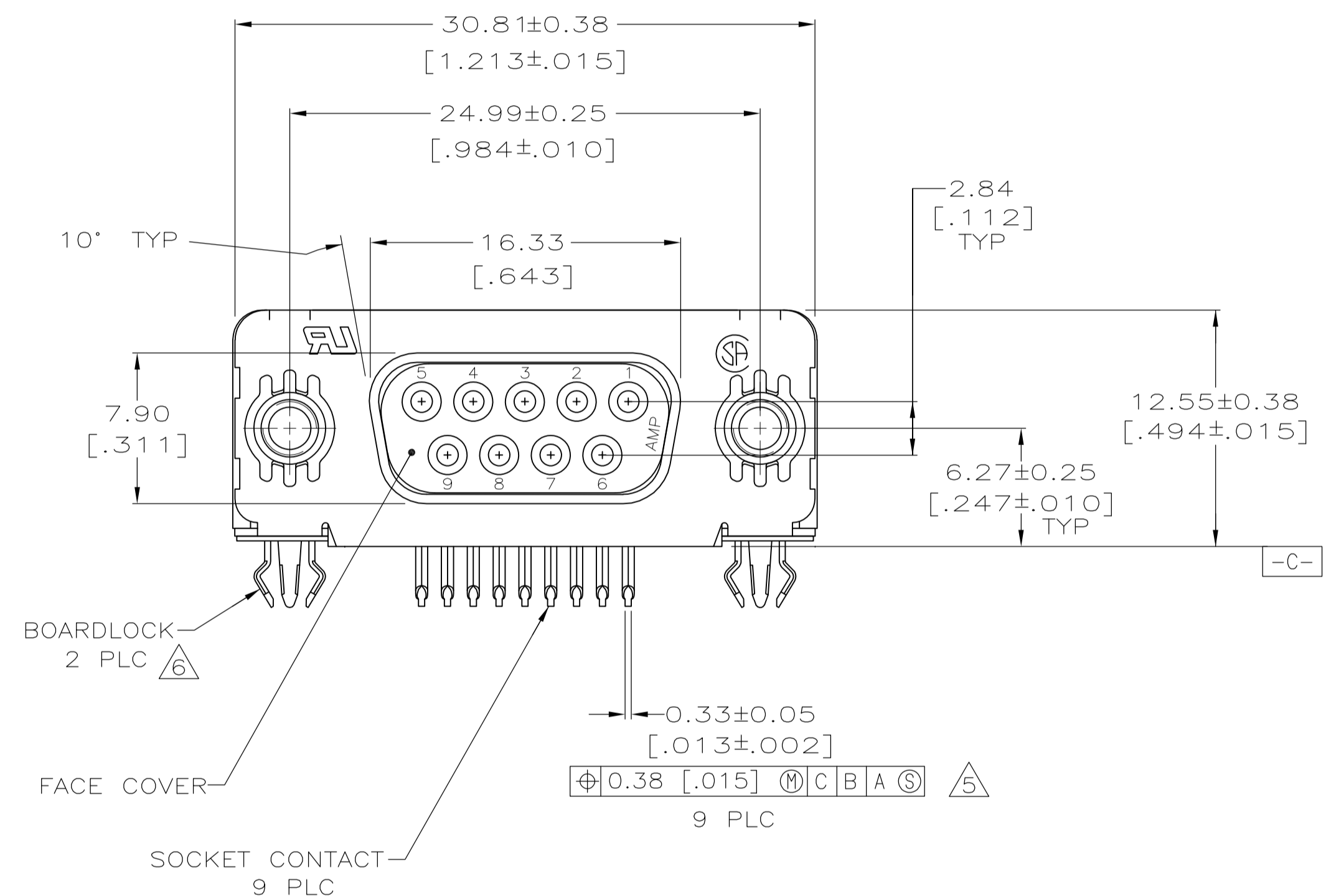
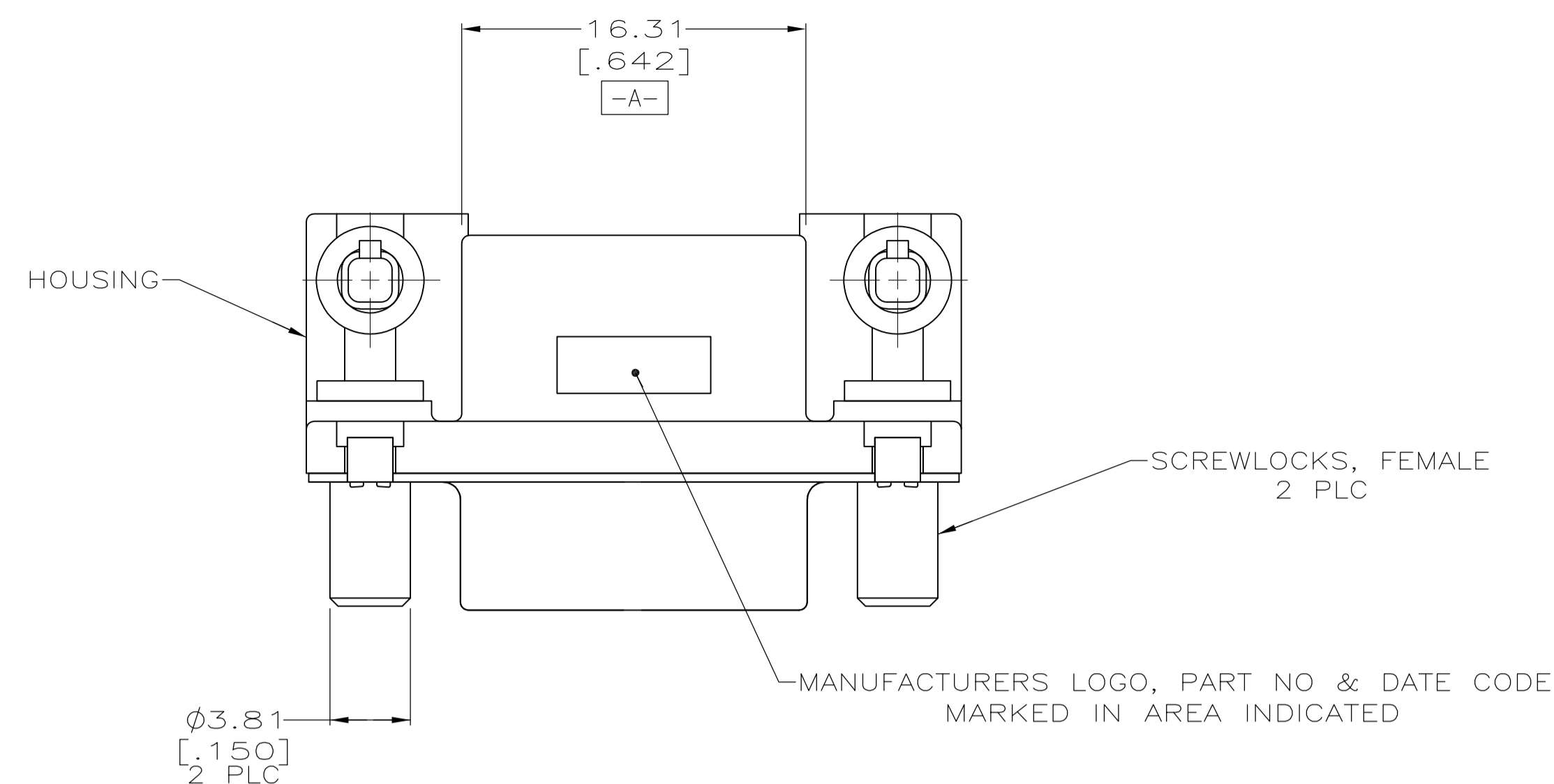

RECOMMENDED PC BOARD LAYOUT  
1.57 [.062] PC BOARD THICKNESS

- △ HOUSING & FACE COVER: NYLON, THERMOPLASTIC, UL 94VO RATED, BLACK; SHELL: CARBON STEEL; SOCKET CONTACTS: PHOSPHOR BRONZE; EYELETS: BRASS; SCREWLOCKS: ZINC; BOARDLOCKS: COPPER ALLOY.
- △ SOCKET CONTACTS: GOLD PLATED FOR A LENGTH OF 1.27 [.050] MIN FROM MATING END, 0.76µm [.000030] MIN GOLD IN MATED AREA, 2.54µm [.000100] MIN TIN FOR A LENGTH OF 3.56 [.140] MIN FROM OPPOSITE END, BOTH OVER 1.27µm [.000050] MIN NICKEL. EYELETS: 2.54µm [.000100] MIN TIN OVER COPPER FLASH. SHELL: 2.54µm [.000100] MIN TIN OVER 1.27µm [.000050] MIN COPPER. SCREWLOCKS: CLEAR CHROMATE. BOARDLOCKS: 3.81µm [.000150] MIN TIN OVER 1.27µm [.000050] MIN NICKEL.
- △ SOCKET CONTACTS: GOLD PLATED FOR A LENGTH OF 1.27 [.050] MIN FROM MATING END, GOLD FLASH IN MATED AREA, 2.54µm [.000100] MIN TIN FOR A LENGTH OF 3.56 [.140] MIN FROM OPPOSITE END, BOTH OVER 1.27µm [.000050] MIN NICKEL. EYELETS: 2.54µm [.000100] MIN TIN OVER COPPER FLASH. SHELL: 2.54µm [.000100] MIN TIN OVER 1.27µm [.000050] MIN COPPER. SCREWLOCKS: CLEAR CHROMATE. BOARDLOCKS: 3.81µm [.000150] MIN TIN OVER 1.27µm [.000050] MIN NICKEL.
- △ DATUMS AND BASIC DIMENSIONS ESTABLISHED BY CUSTOMER.
- △ POSITION TOLERANCE APPLIES AT CONTACT TIP.
- △ BOARDLOCKS WILL ACCEPT .062 MAX PRINTED CIRCUIT BOARD THICKNESS.
- 7. COMPATIBLE WITH SOLDER REFLOW APPLICATIONS TO A MAXIMUM OF 225° C FOR A MAXIMUM DURATION OF 90 SECONDS. TEMPERATURE TO BE MEASURED ON CONNECTOR SURFACE.
- △ SOCKET CONTACTS: GOLD PLATED FOR A LENGTH OF 1.27 [.050] MIN FROM MATING END, 0.76µm [.000030] MIN GOLD IN MATED AREA, 2.54µm [.000100] MIN TIN FOR A LENGTH OF 3.56 [.140] MIN FROM OPPOSITE END, BOTH OVER 1.27µm [.000050] MIN NICKEL. EYELETS: 2.54µm [.000100] MIN TIN OVER COPPER FLASH. SHELL: 2.54µm [.000100] MIN TIN OVER 1.27µm [.000050] MIN COPPER. SCREWLOCKS: STAINLESS STEEL WITH PASSIVATION. BOARDLOCKS: 3.81µm [.000150] MIN TIN OVER 1.27µm [.000050] MIN NICKEL.

△	5788797-3
△	5788797-2
△	5788797-1
FINISH	PART NO

THIS DRAWING IS A CONTROLLED DOCUMENT.		DIN J. ALCORTA - DOCK5 04-11-05	Tyco Electronics Corporation Harrisburg, PA 17105-3608
DIMENSIONS: mm (INCHES)		CIK S. BOLASH 04-11-05	
TOLERANCES UNLESS OTHERWISE SPECIFIED:		APVD M. WALMSLEY 04-11-05	RCPT ASSEMBLY, SIZE 1, .318 SERIES, WITH FRONT METAL SHELL, HIGH TEMPERATURE, AMPLIMITE HD-20
0 PLC ± -		NAME	
1 PLC ± -		PRODUCT SPEC	108-40025
2 PLC ± 0.13 [.005]		APPLICATION SPEC	114-40010
3 PLC ± -		SIZE	A1
4 PLC ± -		WEIGHT	00779 C=5788797
ANGLES ± °		CUSTOMER DRAWING	SCALE 4:1 SHEET 1 of 1 REV A