



Chipsmall Limited consists of a professional team with an average of over 10 year of expertise in the distribution of electronic components. Based in Hongkong, we have already established firm and mutual-benefit business relationships with customers from,Europe,America and south Asia,supplying obsolete and hard-to-find components to meet their specific needs.

With the principle of “Quality Parts,Customers Priority,Honest Operation,and Considerate Service”,our business mainly focus on the distribution of electronic components. Line cards we deal with include Microchip,ALPS,ROHM,Xilinx,Pulse,ON,Everlight and Freescale. Main products comprise IC,Modules,Potentiometer,IC Socket,Relay,Connector.Our parts cover such applications as commercial,industrial, and automotives areas.

We are looking forward to setting up business relationship with you and hope to provide you with the best service and solution. Let us make a better world for our industry!



## Contact us

Tel: +86-755-8981 8866 Fax: +86-755-8427 6832

Email & Skype: info@chipsmall.com Web: www.chipsmall.com

Address: A1208, Overseas Decoration Building, #122 Zhenhua RD., Futian, Shenzhen, China



**PROPER USE GUIDELINES**

Cumulative Trauma Disorders can result from the prolonged use of manually powered hand tools. Hand tools are intended for occasional use and low volume applications. A wide selection of powered application equipment for extended-use, production operations is available.

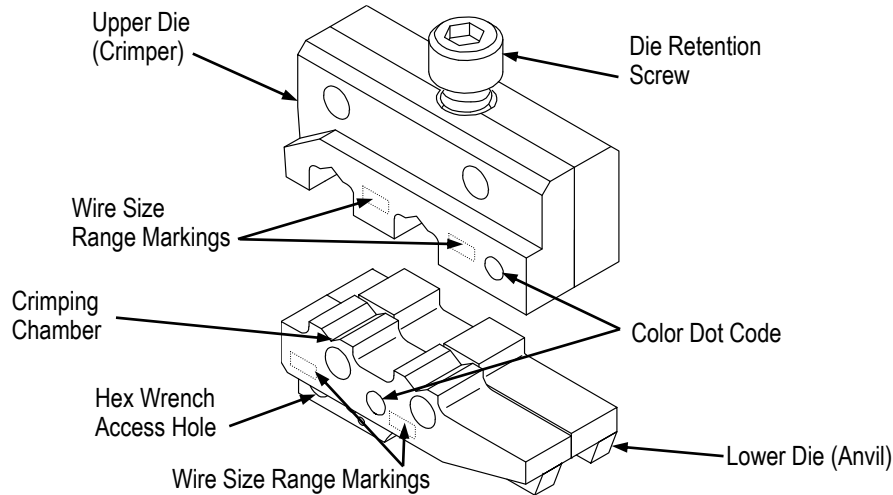

Figure 1

**1. INTRODUCTION**

This instruction sheet covers application and maintenance procedures for Crimping Die Assemblies 58079-3 and 58080-3. See Figure 1. Each die assembly is used with Hand Crimping Tool Frame 58078-3, which will crimp the Ultra-Fast Plus Fully Insulated FASTON\* Terminals listed in Figure 2.

Refer to Instruction Sheet [408-6976](#) (supplied with tool frame) for specific tooling information. Product part number information is available in Catalog 82004.



**NOTE**

*Dimensions are in millimeters [with inch equivalents in brackets]. Figures are for identification only and are not drawn to scale.*

Reasons for reissue are provided in Section 7, REVISION SUMMARY.

**2. DESCRIPTION**

Each die assembly consists of an upper die (crimper) and a lower die (anvil), a die retention screw (on upper die), and a hex wrench for securing the socket head setscrew to the lower die and onto the hand tool platform. When mated, the dies form two crimping chambers, each marked with the wire size range.

The die assemblies are identified by the part number, color dot code, and applicable wire range markings. Refer to Figure 2. The color dot code on the die assembly must match the color-coded terminal.

**3. DIE ASSEMBLY INSTALLATION**

**3.1. Installing Lower Die**

1. Close tool frame handles until ratchet releases, then allow handles to open FULLY.
2. Slide lower die onto lower jaw platform of tool frame. Make sure that the hole on the side of the lower die aligns with the socket head setscrew already installed in the lower jaw platform. See Figure 3.



**NOTE**

*If lower die will not position properly, use hex wrench provided with die assembly to turn socket head setscrew either in or out until lower die positions properly. The setscrew must be flush on both sides.*

3. Using hex wrench, turn socket head setscrew CLOCKWISE until snug. Do NOT over-tighten.

### 3.2. Installing Upper Die

1. Remove die retention screw from upper die.
2. Slide upper die onto upper jaw platform of tool frame. Make sure the color dot code on upper die is on the same side as the color dot code on lower die. See Figure 3.

WIRE		ULTRA-FAST PLUS TERMINALS		DIE ASSEMBLY	
SIZE (AWG)	INSUL DIA (MAX)	SERIES	PART NO.	COLOR CODE DOT	PART NO.
22-18	3.43 [.135]	.187	2-520409-2	Red	58079-3
			2-520411-2		
		.250	2-520407-2		
16-14	4.06 [.160]	.187	3-520410-2	Blue	58080-3
			3-520412-2		
		.250	3-520408-2		

Figure 2

3. Insert die retention screw through mounting hole in top of tool frame and thread, but do not tighten, the screw.
4. Carefully close the tool handles, making sure that the dies align properly.
5. Tighten the die retention screw until secure.

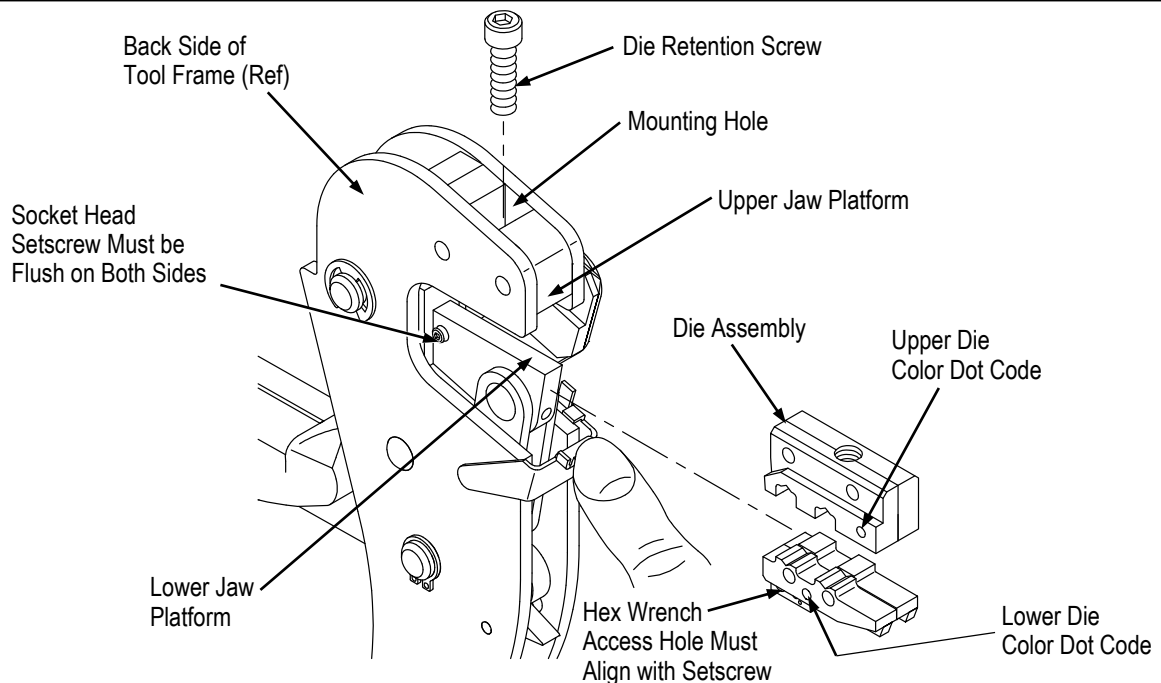

Figure 3

### 4. CRIMPING PROCEDURE

Select the appropriate wire size and terminal for the die assembly. The wire size and insulation diameter must be within a specified range for the terminal. Strip the wire to the appropriate length shown in Figure 4. Do NOT cut or nick the wire strands. Then, proceed as follows:

1. Hold tool frame so that the FRONT side is facing you and open crimping dies by squeezing tool frame handles together until ratchet releases.
2. The locator stop must be adjusted to accommodate the terminal series size, which is marked on the terminal insulation (.187 or .250). Rotate the blue plastic locator stop until the series size number, appearing in the uppermost position, matches the terminal series size. Refer to Figure 4.

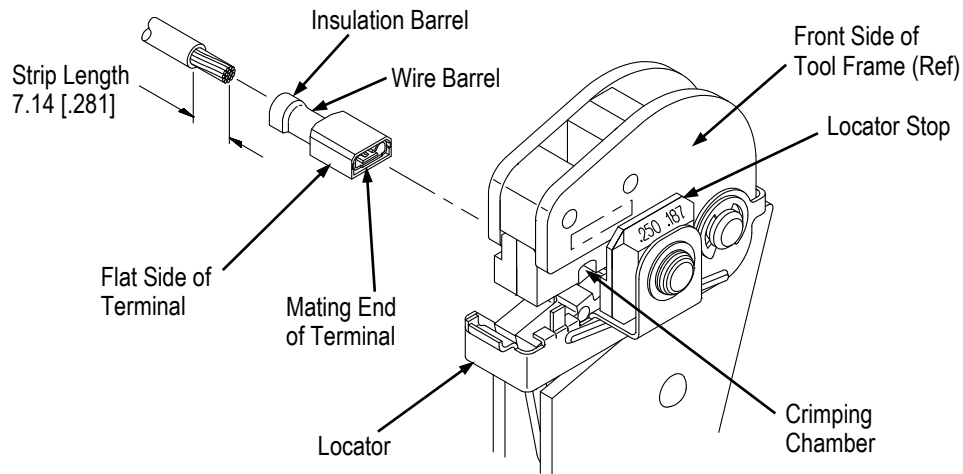

Figure 4

3. Push the locator assembly away from the upper crimping die slightly and hold.
4. Insert terminal mating end, flat side facing locator, in the BACK side of the tool frame; center on the appropriate crimping chamber on the lower crimping die. Allow terminal to butt against locator stop. See Figure 4.
5. Holding terminal in position, release locator assembly. Insert stripped wire into wire barrel until wire bottoms.
6. Hold wire in position and maintain light pressure. Then, squeeze tool frame handles together until ratchet releases.
7. Allow tool frame handles to open FULLY. Holding locator assembly in position, remove crimped terminal.

## 5. MAINTENANCE AND INSPECTION

### 5.1. Maintenance

1. Remove dust, moisture and other contaminants with a clean brush, or a soft, lint-free cloth. Do not use objects that could damage the dies.
2. Make certain that all surfaces are protected with a thin coat of any good SAE 20 motor oil. Do not oil excessively.
3. When dies are not in use, store in a clean, dry area.

### 5.2. Periodic Inspection

Regular inspections should be performed with a record of inspections remaining with the dies and/or supervisory personnel responsible for them. TE Connectivity recommends one inspection per month; however, amount of use, working conditions, operator training and skill, and established company standards should determine frequency of inspection. The inspection should be performed in the following sequence:

#### A. Visual Inspection

1. Remove all lubrication and accumulated film by immersing the dies in a suitable commercial degreaser that will not affect paint or plastic material.
2. Make sure the die retention screw and die components are in place and secured. Refer to Section 6, REPLACEMENT AND REPAIR, if replacements are necessary.
3. Check all bearing surfaces for wear. Replace worn components.
4. Inspect the crimping chambers for flattened, chipped, cracked, worn, or broken areas. If damage is evident, the dies must be repaired before returning them to service. See Section 6, REPLACEMENT AND REPAIR.

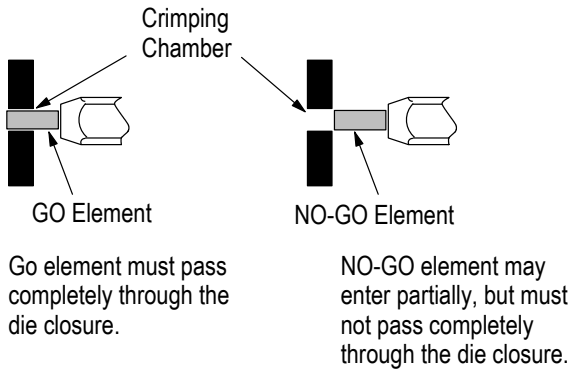
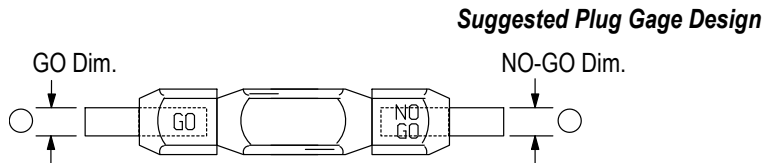

DIE ASSEMBLY		ELEMENT DIAMETER	
PART NO.	WIRE SIZE MARKING	GO	NO-GO
58079-3	22-20	1.575-1.582 [.0620-.0623]	1.725-1.727 [.0679-.0680]
	18	1.702-1.709 [.0670-.0673]	1.852-1.854 [.0729-.0730]
58080-3	16	1.829-1.836 [.0720-.0723]	1.979-1.981 [.0779-.0780]
	14	1.956-1.963 [.0770-.0773]	2.106-1.108 [.0829-.0830]

Figure 5

### B. Gaging the Crimping Chamber

This inspection requires the use of a plug gage conforming to the diameters in Figure 5. TE does not manufacture or market these gages. To gage the crimping chambers, proceed as follows:

1. Remove traces of oil or dirt from the crimping chambers and plug gage.
2. Mate the dies until it is evident that the dies have bottomed, then HOLD in this position. Do NOT force the dies beyond initial contact.
3. Align the GO element with the crimping chamber. Push element straight into the crimping chamber without using force. The GO element must pass completely through. Refer to Figure 5.
4. Now align the NO-GO element and try to insert it straight into the same crimping chamber. The NO-GO element may start entry but must not pass completely through as shown in Figure 5.

If the crimping chambers conform to the gage inspection, the die assembly is considered dimensionally correct and should be lubricated with a THIN coat of any good SAE 20 motor oil. If not, the die assembly must be repaired before returning it to service. See Section 6, REPLACEMENT AND REPAIR.

For additional information concerning the use of the plug gage, refer to Instruction Sheet 408-7424.

## 6. REPLACEMENT AND REPAIR

Customer-replaceable parts are listed in Figure 6. Parts other than those listed should be replaced by TE to ensure quality and reliability. For customer repair service or to order replacement parts, call 1-800-522-6752, or fax your purchase order to 717-986-7605, or write to:

Customer Service (038-035),  
Tyco Electronics Corporation  
PO Box 3608  
Harrisburg, PA 17105-3608.

## 7. REVISION SUMMARY

- Updated document to corporate requirements
- Added new callouts to Figures 1 and 3
- Added new text to Paragraph 3.1 and NOTE in 3.1
- Added new information to table in Figure 6

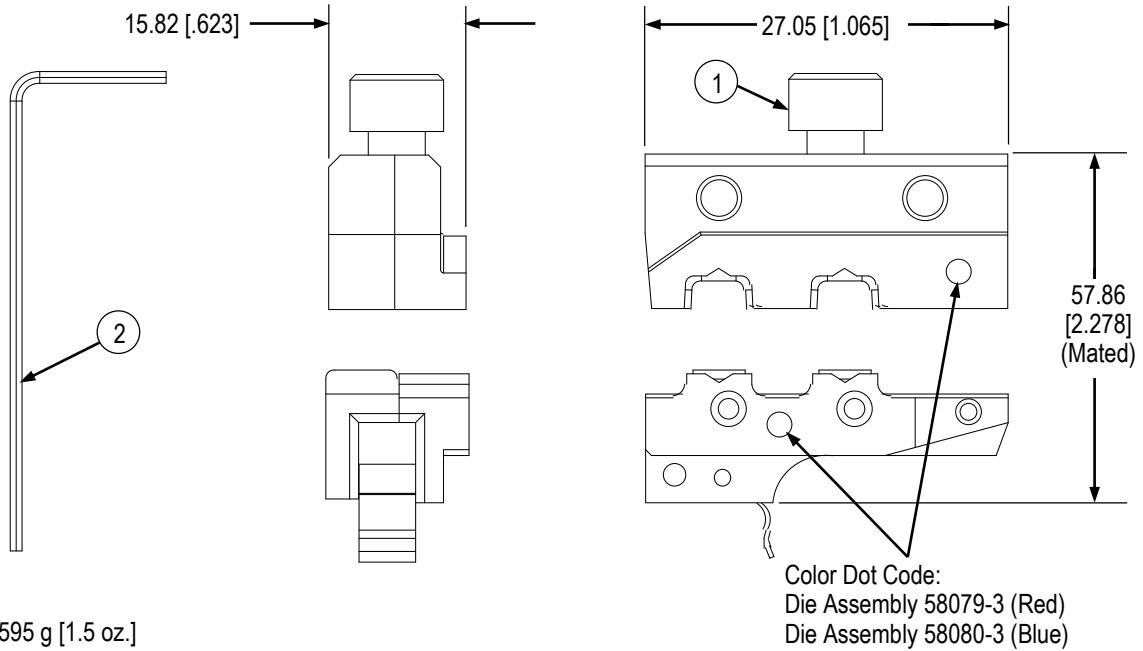

**WEIGHT:** 595 g [1.5 oz.]

**REPLACEMENT PARTS**

ITEM	PART NUMBER	DESCRIPTION	QTY PER ASSEMBLY
1●	3-21000-4	SCREW, Die Retention	1
2	21027-3	WRENCH, Hex	1

- A hex head setscrew is already installed in the hand tool lower jaw platform. This setscrew is a spare part.

Figure 6