



Chipsmall Limited consists of a professional team with an average of over 10 year of expertise in the distribution of electronic components. Based in Hongkong, we have already established firm and mutual-benefit business relationships with customers from,Europe,America and south Asia,supplying obsolete and hard-to-find components to meet their specific needs.

With the principle of “Quality Parts,Customers Priority,Honest Operation,and Considerate Service”,our business mainly focus on the distribution of electronic components. Line cards we deal with include Microchip,ALPS,ROHM,Xilinx,Pulse,ON,Everlight and Freescale. Main products comprise IC,Modules,Potentiometer,IC Socket,Relay,Connector.Our parts cover such applications as commercial,industrial, and automotives areas.

We are looking forward to setting up business relationship with you and hope to provide you with the best service and solution. Let us make a better world for our industry!



Contact us

Tel: +86-755-8981 8866 Fax: +86-755-8427 6832

Email & Skype: info@chipsmall.com Web: www.chipsmall.com

Address: A1208, Overseas Decoration Building, #122 Zhenhua RD., Futian, Shenzhen, China



Crimping Die Assemblies 58237-1 and 58237-2

PROPER USE GUIDELINES

Cumulative Trauma Disorders can result from the prolonged use of manually powered hand tools. Hand tools are intended for occasional use and low volume applications. A wide selection of powered application equipment for extended-use, production operations is available.

**Die Assembly
58237-1**

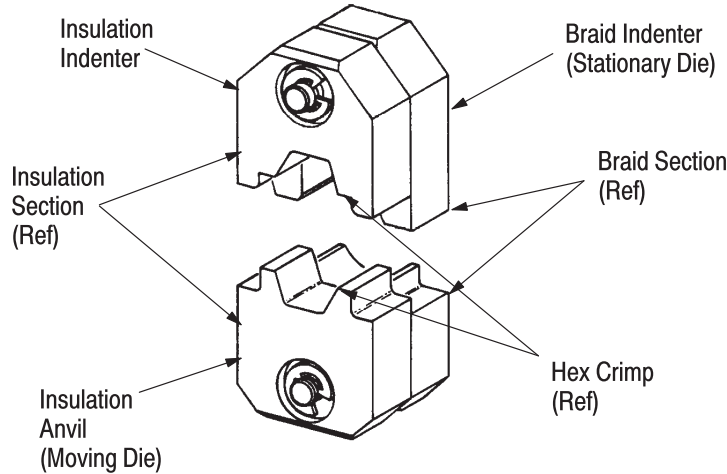

**Typical
Shielding
Hardware Kit
(Ref)**

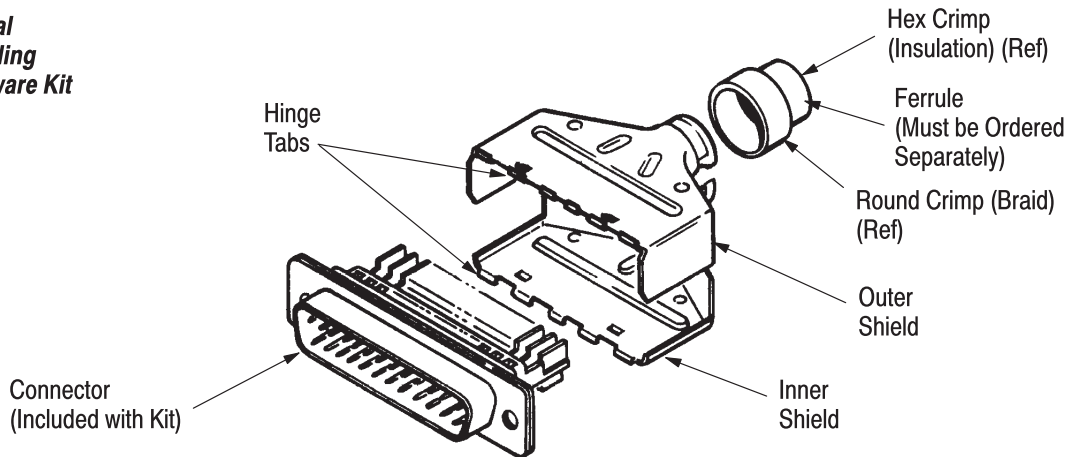

FERRULE PART NO.†	CABLE DIA RANGE	CRIMPING DIE ASSEMBLY	HAND CRIMP TOOL	DIE HOLDER††	PNEUMATIC APPLICATOR	NUMBER OF CONTACTS
2-747580-2	12.19 - 14.27 [.480 - .562]	58237-1	543344-1	58449-1	312522-3	37
3-747580-1	10.72 - 12.45 [.422 - .490]	58237-2	543344-1	58449-1	312522-3	37 and 50

† Must be ordered separately from shield kits.

Figure 1

†† Used with Pneumatic Applicator 312522-3

1. INTRODUCTION

Crimping Die Assemblies 58237-1 and 58237-2 are designed to crimp ferrules onto AMPLIMITE* Shielding Hardware Kits shown in Figure 1.

The die assemblies may be used in Hand Crimping Tool 543344-1 or in Die Holder 58449-1. The die

holder is used in conjunction with Pneumatic Applicator 312522-3. For die installation and crimping procedures, refer to Instruction Sheet 408-9315, packaged with the hand tool, and Customer Manual 409-5843, packaged with the pneumatic tool.

Read these and all referenced materials before using the die assemblies.

NOTE

All dimensions on this document are in metric units [with U.S. customary units in brackets].

Reasons for reissue are provided in Section 7, REVISION SUMMARY.

2. DESCRIPTION (Figure 1)

Each die assembly features an anvil (moving die) subassembly and an indenter (stationary die) subassembly. The die assembly crimps the braid and insulation sections of a ferrule onto the cable outlet of a shield assembly and onto the cable insulation. The indenter subassembly remains stationary within the tooling while the anvil moves during the crimping operation.

3. ASSEMBLY

The anvil and indenter subassemblies are designed to fit securely into the desired tooling. They are retained by upper and lower die holder plates.

1. Select appropriate die assembly from the chart in Figure 1. Install dies in the tooling according to installation procedures provided in the instructions packaged with the tooling.
2. Refer to Figure 1 for selection and orientation of the ferrule on the cable.

NOTE

Refer to 408-9010 for procedures regarding the termination of conductors and preparation of connector assembly prior to shield installation. Refer also to 408-9010 for shield installation procedure and basic crimping information.

4. CRIMPING PROCEDURE (Figure 2)

With the ferrule properly oriented on the cable, the cable conductors terminated in the connector, and the shield installed, proceed as follows:

1. Slide the ferrule forward over the cable outlet of the shield assembly.
2. Open the head of the hand tool or ensure that the pneumatic applicator die holder is prepared for crimping.
3. Place the ferrule in the die assembly.
4. If using the hand tool, close and latch the tool head in place.
5. Make certain that the ferrule is maintained in proper position, and close tool handles completely (or actuate dies in pneumatic applicator die holder) to complete the crimp.

5. MAINTENANCE AND INSPECTION**5.1. Daily Maintenance**

1. Remove dust, moisture, and other contaminants with a clean brush, or a soft, lint-free cloth. Do not use objects that could damage the dies.
2. Make sure that dies are properly aligned and that die holding screws are in place and secured.
3. Make certain the dies are protected with a thin coat of any good SAE 20 motor oil. Do not oil excessively.
4. When the dies are not in use, store in a clean, dry area.

**Hand Tool
543344-1
(Ref)**

Figure 2

5.2. Visual Inspection

Regular inspections should be performed, and a record of inspections should remain with the dies and be provided to supervisory personnel responsible for them. Tyco Electronics recommends one inspection per month; however, amount of use, working conditions, operator training and skill, and established company standards should determine frequency of inspection. The inspection should be performed in the following sequence:

1. Remove all lubrication and accumulated film from the dies by immersing the dies in a suitable commercial degreaser that will not affect paint or plastic material.
2. Make sure all die holding screws are in place and secured.
3. Check all bearing surfaces for wear. Replace worn components.
4. Inspect the crimping chambers for flattened, chipped, cracked, worn, or broken areas. If

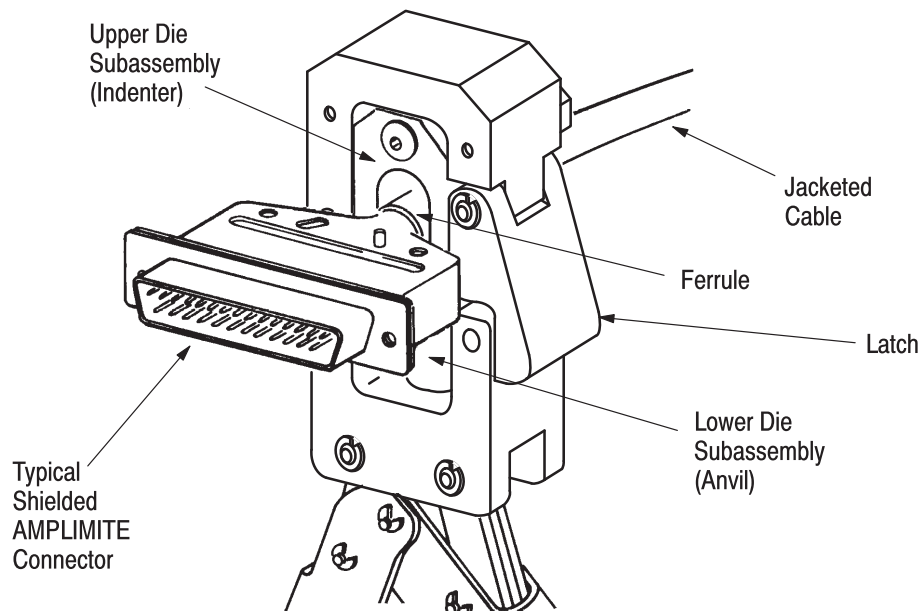
damage is evident, the dies must be repaired before returning them to service. See Section 6, REPLACEMENT AND REPAIR.

5.3. Gaging the Crimping Chamber

This inspection requires the use of a plug gage conforming to the dimensions provided in Figure 3. Tyco Electronics does not manufacture or market these gages. Proceed as follows:

1. Remove traces of oil or dirt from the crimping chamber and plug gage.
2. Actuate the tool, according to the instructions packaged with the tool, until it is evident that the dies have bottomed; then hold in this position. Do NOT force beyond initial contact.
3. With dies bottomed, check the die closure using the proper plug gage. Hold gage in straight alignment with the crimping chamber and carefully try to insert, without forcing, the GO element. The GO element must pass completely through the die closure.

Suggested Plug Gage Design - Insulation Crimp

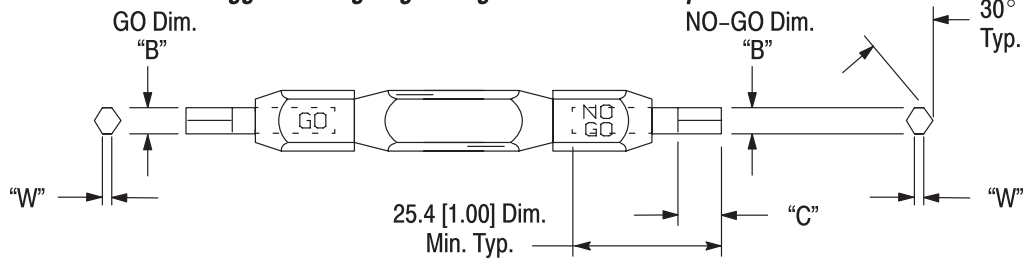

DIE ASSEMBLY	GAGE ELEMENT DIMENSIONS			
	DIMENSION "B"		DIM. "C" (Min.)	DIM. "W" (Max.)
	GO	NO-GO		
58237-1	12.471-12.479 [.4910-.4913]	12.697-12.700 [.4999-.5000]	12.70 [.500]	6.32 [.249]
58237-2	10.998-11.006 [.4330-.4333]	11.223-11.227 [.4419-.4420]	12.70 [.500]	5.49 [.216]

Suggested Plug Gage Design - Braid Crimp

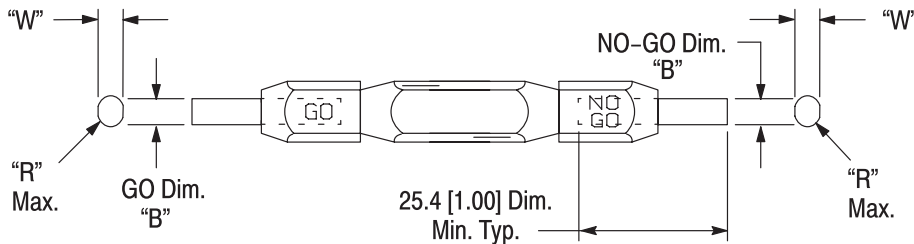

DIE ASSEMBLY	GAGE ELEMENT DIMENSIONS			
	DIMENSION "B"		"W" (Max.)	RADIUS "R" (Max.)
	GO	NO-GO		
58237-1	13.411-13.419 [.5280-.5283]	13.536-13.538 [.5329-.5330]	12.70 [.500]	6.35 [.250]
58237-2				

Figure 3

4. Try to insert the NO-GO element. The NO-GO element may enter partially, but must not pass completely through the length of the die closure.
5. Repeat Steps 3 and 4 for each crimp section listed in the chart.

If the crimping chambers conform to the gage inspection, the die assembly may be considered dimensionally correct, and should be lubricated with a THIN coat of any good SAE 20 motor oil. If not, the die assembly must be returned to Tyco Electronics for further evaluation and repair. Refer to Section 6, REPLACEMENT AND REPAIR.

For additional information regarding the use of plug gages, refer to 408-7424.

6. REPLACEMENT AND REPAIR

Customer-replaceable parts are listed in Figure 4. A complete inventory can be stocked and controlled

to prevent lost time when replacement of parts is necessary. Order replacement parts through your Tyco Electronics representative, or call 1-800-526-5142, or send a facsimile of your purchase order to 1-717-986-7605, or write to:

CUSTOMER SERVICE (38-35)
 TYCO ELECTRONICS CORPORATION
 P.O. BOX 3608
 HARRISBURG, PA 17105-3608

7. REVISION SUMMARY

Revisions to this instruction sheet include:

- Replaced ferrule parts in Figure 1 with numbers for superseding RoHS compliant parts.
- Replaced obsolete hand tool references and artwork with current active hand tool.
- Added proper use guidelines.
- Updated document to corporate requirements.

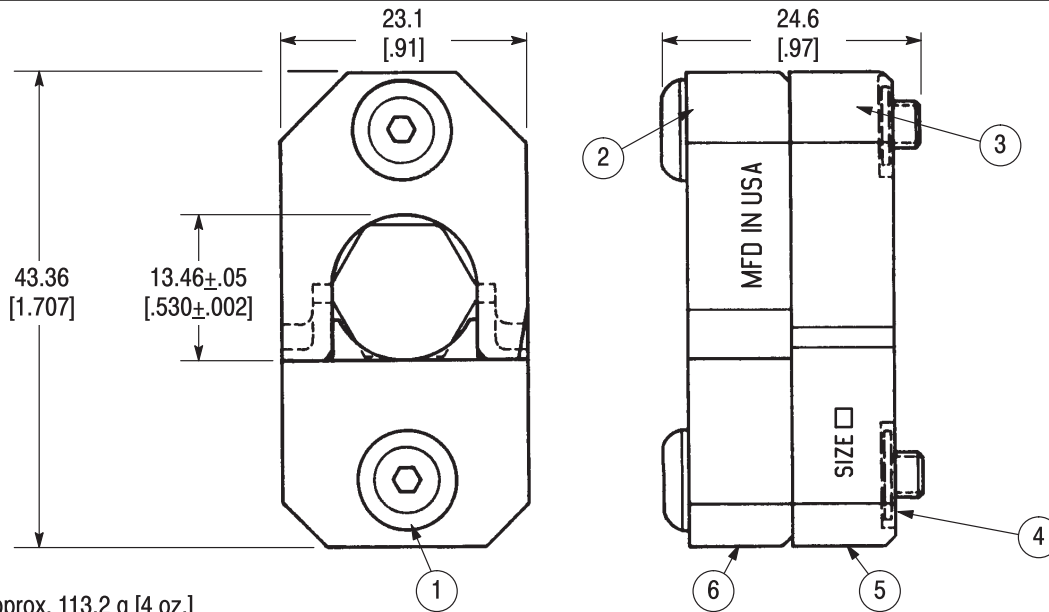

Weight: Approx. 113.2 g [4 oz.]

CUSTOMER-REPLACEABLE PARTS

ITEM	DIE ASSEMBLY PART NUMBER		DESCRIPTION	QTY PER ASSY
	58237-1	58237-2		
1	306105-7	306105-7	SCREW, Special	2
2	313164-2	313164-2	INDENTER, (Stationary Die)	1
3	313173-1	313173-2	INDENTER, Insulation	1
4	1- 21046-3	1- 21046-3	RING, Retaining	2
5	313174-1	313174-2	ANVIL, Insulation	1
6	313170-1	313170-1	ANVIL, (Moving Die)	1

Figure 4