



Chipsmall Limited consists of a professional team with an average of over 10 year of expertise in the distribution of electronic components. Based in Hongkong, we have already established firm and mutual-benefit business relationships with customers from,Europe,America and south Asia,supplying obsolete and hard-to-find components to meet their specific needs.

With the principle of “Quality Parts,Customers Priority,Honest Operation,and Considerate Service”,our business mainly focus on the distribution of electronic components. Line cards we deal with include Microchip,ALPS,ROHM,Xilinx,Pulse,ON,Everlight and Freescale. Main products comprise IC,Modules,Potentiometer,IC Socket,Relay,Connector.Our parts cover such applications as commercial,industrial, and automotives areas.

We are looking forward to setting up business relationship with you and hope to provide you with the best service and solution. Let us make a better world for our industry!



Contact us

Tel: +86-755-8981 8866 Fax: +86-755-8427 6832

Email & Skype: info@chipsmall.com Web: www.chipsmall.com

Address: A1208, Overseas Decoration Building, #122 Zhenhua RD., Futian, Shenzhen, China



PROPER USE GUIDELINES

Cumulative Trauma Disorders can result from the prolonged use of manually powered hand tools. Hand tools are intended for occasional use and low volume applications. A wide selection of powered application equipment for extended-use, production operations is available.

1. INTRODUCTION

*Tool Kit with
Base Part No.
58241-[]*

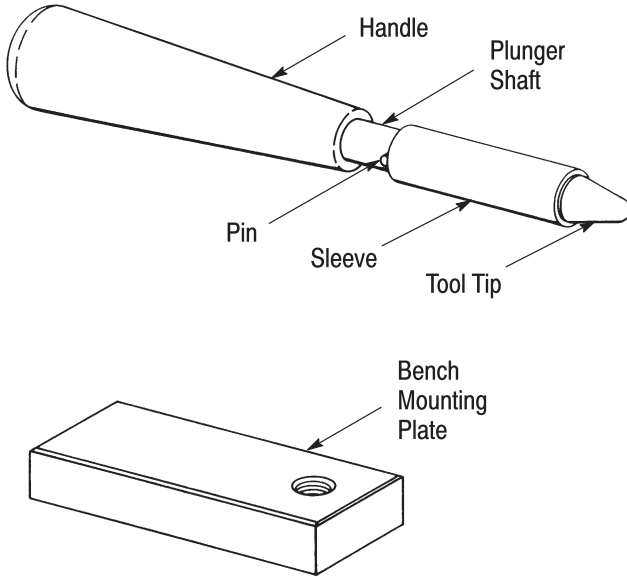

TOOL KIT	58241-1	58241-2	58241-4
Cable Dia (Max)	11.43 [.450]	14.53 [.572]	8.38 [.330]
Handle	27152-2	27152-2	18963-1
Bench Mtg. Plate	313183-1	313183-1	---
Plunger/sleeve Assy	313196-1	313196-2	313196-3

Figure 1

2. INTRODUCTION

This instruction sheet covers use and maintenance of Shielding Enclosure Expansion Tool Kits 58241-1, 58241-2, and 58241-4. These tools are used to expand the cable outlet of shielding enclosures for AMPLIMITE* connectors, allowing the enclosure to be inserted easily over cable.



Dimensions in this instruction sheet are in metric units [with U.S. customary units in brackets]. Figures and illustrations are for identification only and are not drawn to scale.

Read these instructions thoroughly before using the cover extraction tool.

Reasons for reissue of this instruction sheet are provided in Section 5, REVISION SUMMARY.

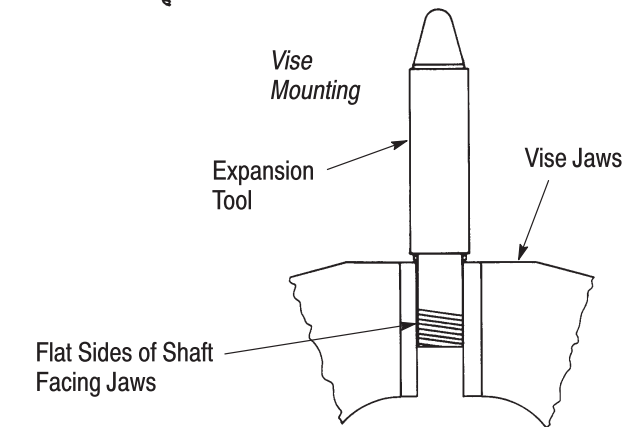
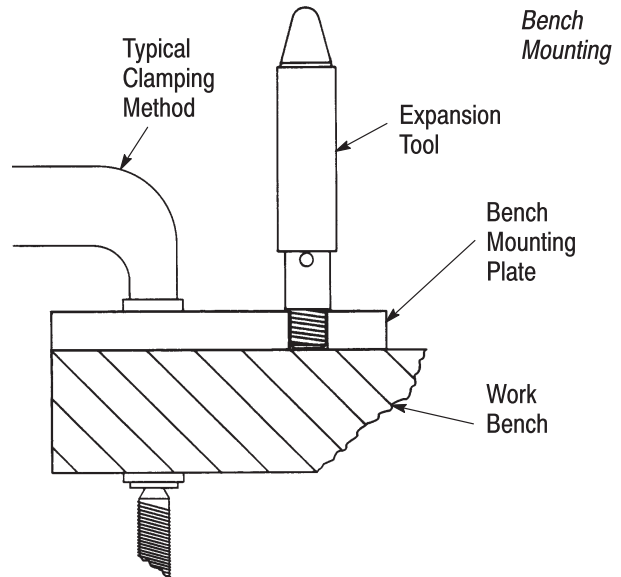

Figure 2

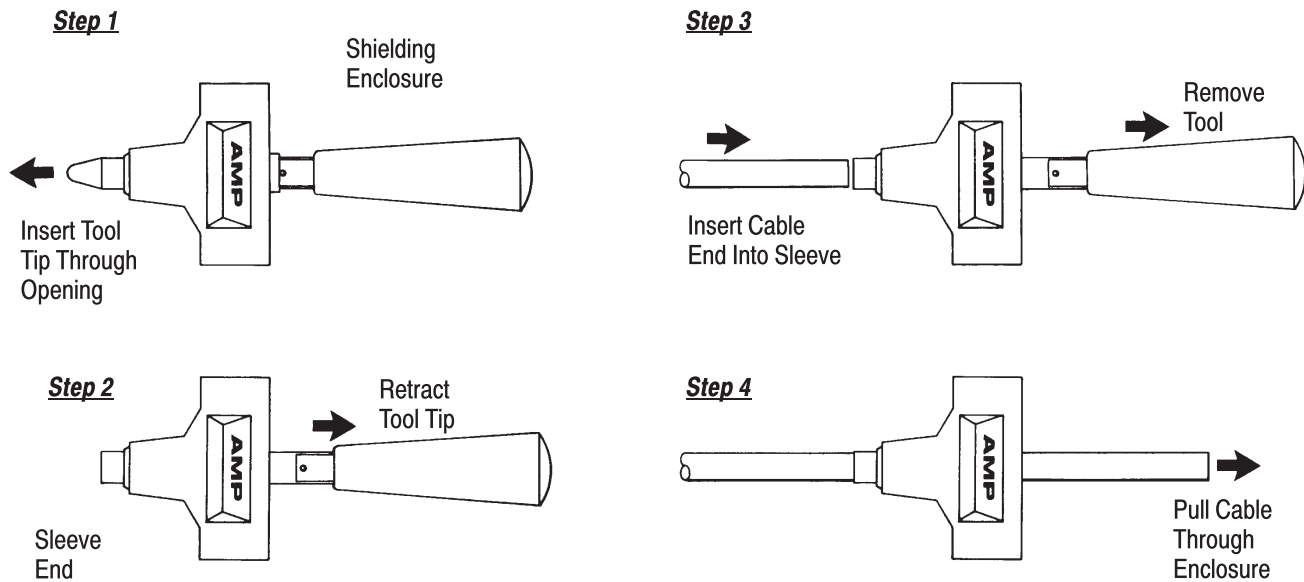

Figure 3

3. DESCRIPTION (See Figure 1)

The tools feature a metal plunger and sliding sleeve. There is a pin in the plunger shaft that limits how far the plunger can extend past the end of the sleeve. The plunger shaft is threaded to receive a plastic handle, or to be used with a bench mounting plate. The handle and mounting plate are included in the kit.

The threaded end of the plunger is flat on both sides so that it can also be mounted in a vise. Figure 2 shows typical bench and vise mountings.

4. USING THE TOOL

Figure 3 shows the steps for using the tool. Steps are the same whether tool is hand held or mounted. Make sure tool and cable diameter are compatible according to the table in Figure 1. Then:

1. Insert extended tool tip and sleeve through cable opening of shielding enclosure.
2. Retract tool tip into sleeve.
3. Insert cable end into sleeve. Hold enclosure in position on cable, and remove tool from the enclosure.

4. Carefully slide cable through enclosure so that enough cable protrudes to apply the connector and shielding. Instruction sheet 408-9172 covers connector application procedures; and 408-9218 covers shielding.

5. MAINTAINING THE TOOL

Inspect the tool when you receive it and occasionally thereafter. When not in use, store tool in a clean, dry area. If parts are lost or damaged, refer to Figure 1 for the correct part numbers, and order replacements from:

CUSTOMER SERVICE (38-35)
 TYCO ELECTRONICS CORPORATION
 P.O. BOX 3608
 HARRISBURG, PA 17105-3608

For tool repair service, please contact a Tyco Electronics representative at 1-800-526-5136.

6. REVISION SUMMARY

Since the previous release of this sheet, the following changes were made:

- Updated document to corporate requirements