



Chipsmall Limited consists of a professional team with an average of over 10 year of expertise in the distribution of electronic components. Based in Hongkong, we have already established firm and mutual-benefit business relationships with customers from,Europe,America and south Asia,supplying obsolete and hard-to-find components to meet their specific needs.

With the principle of “Quality Parts,Customers Priority,Honest Operation,and Considerate Service”,our business mainly focus on the distribution of electronic components. Line cards we deal with include Microchip,ALPS,ROHM,Xilinx,Pulse,ON,Everlight and Freescale. Main products comprise IC,Modules,Potentiometer,IC Socket,Relay,Connector.Our parts cover such applications as commercial,industrial, and automotives areas.

We are looking forward to setting up business relationship with you and hope to provide you with the best service and solution. Let us make a better world for our industry!



Contact us

Tel: +86-755-8981 8866 Fax: +86-755-8427 6832

Email & Skype: info@chipsmall.com Web: www.chipsmall.com

Address: A1208, Overseas Decoration Building, #122 Zhenhua RD., Futian, Shenzhen, China



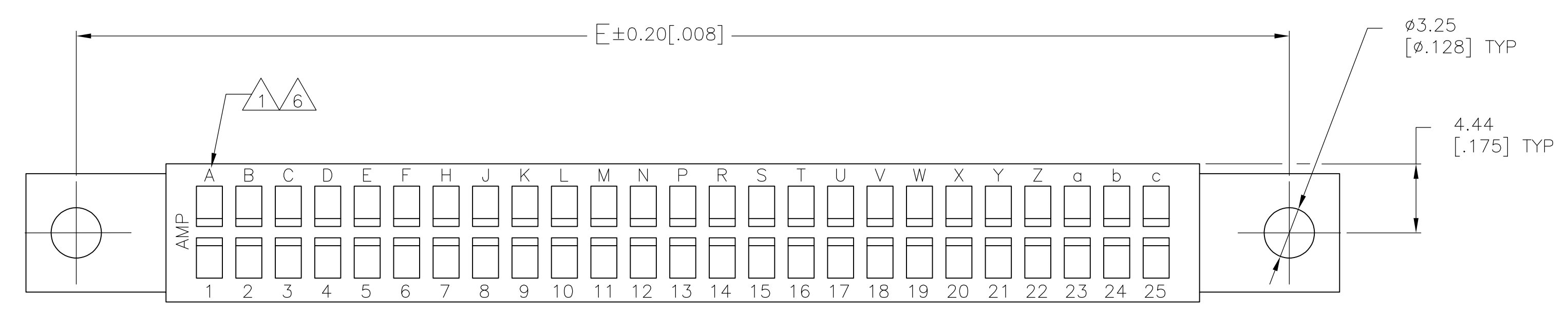
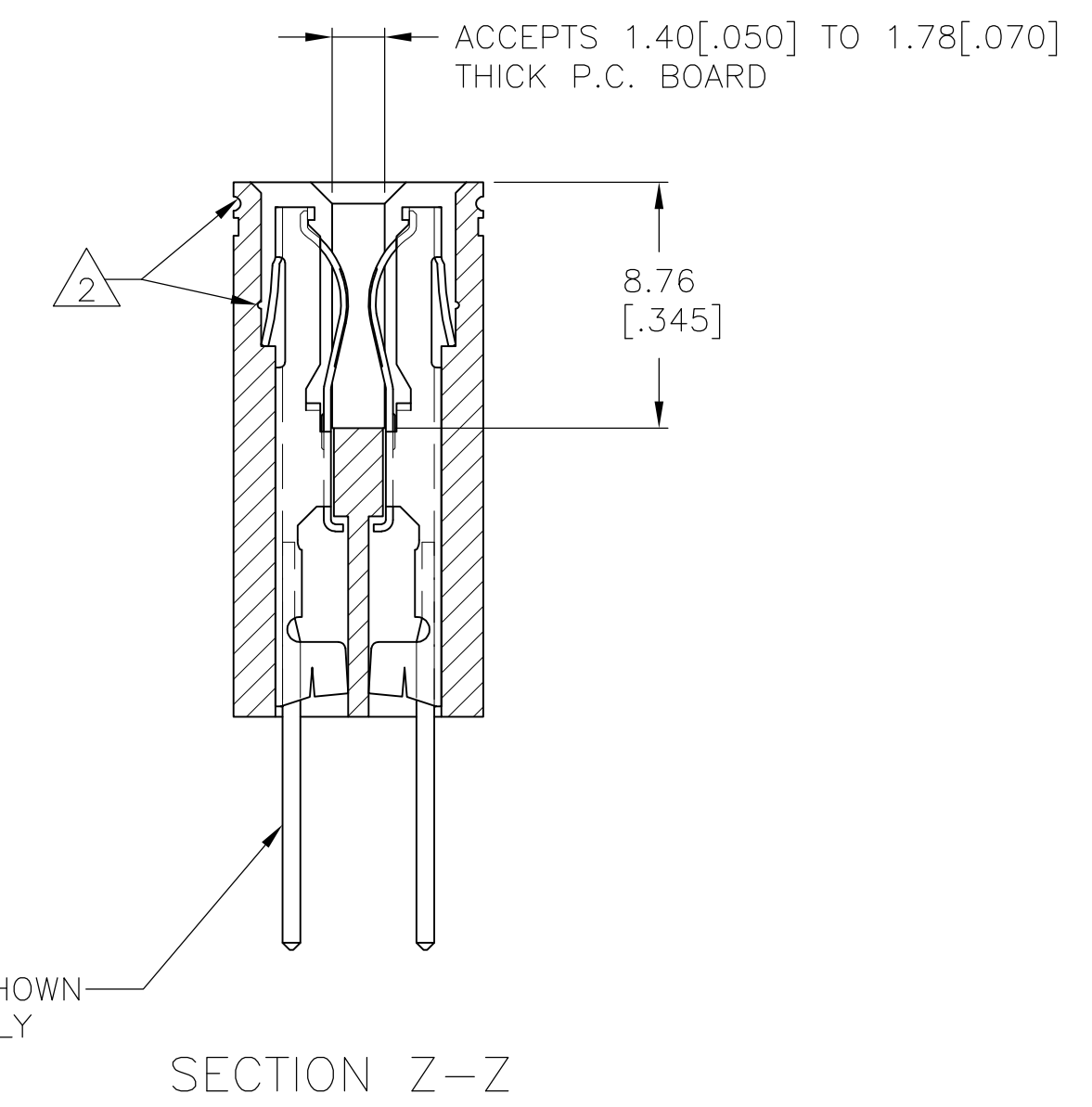
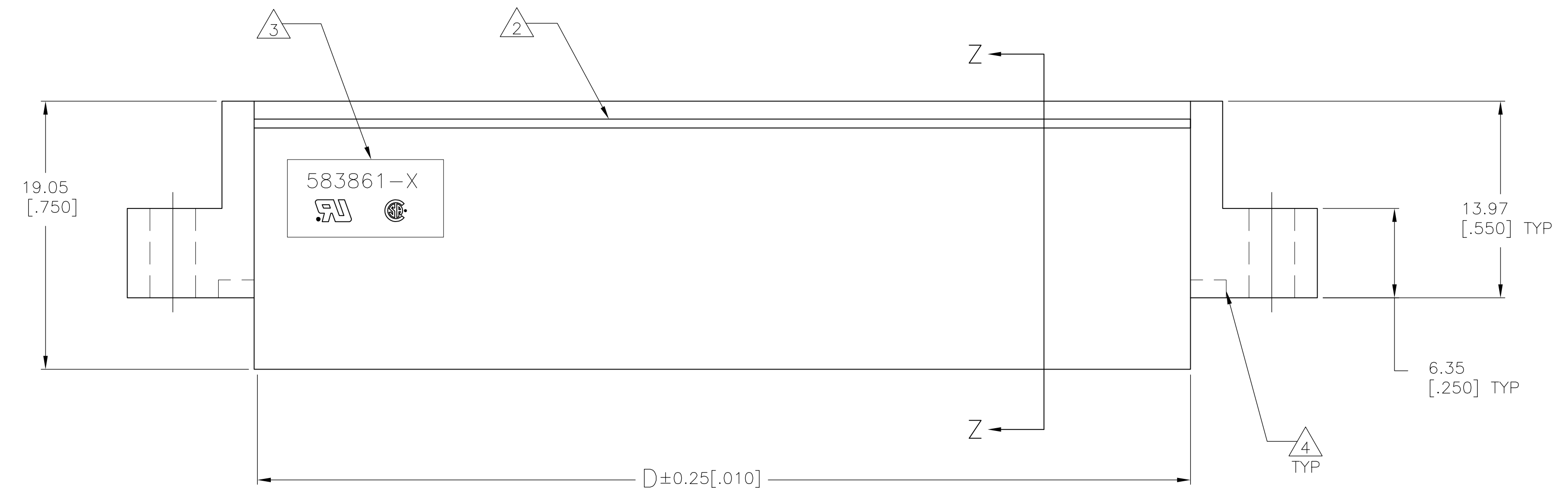
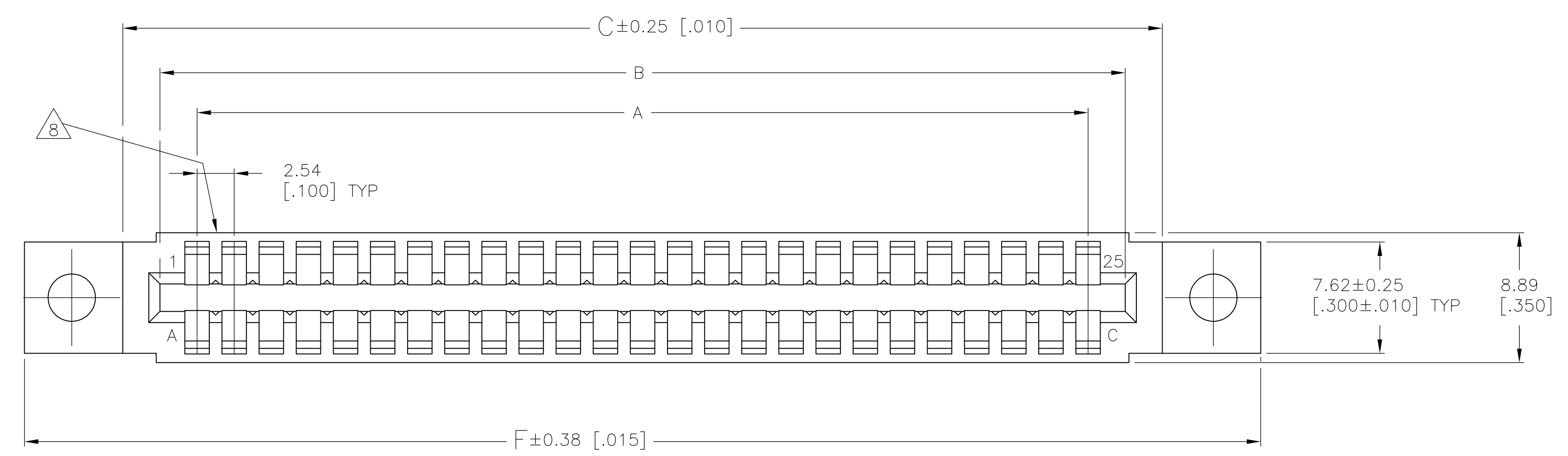

THIS DRAWING IS A CONTROLLED DOCUMENT.		DIN J GALLUCCI BG 10DEC92		TE Connectivity	
DIMENSIONS: mm [INCHES]		TOLERANCES UNLESS OTHERWISE SPECIFIED:			
0. PLC ± - 1. PLC ± - 2. PLC ± - 3. PLC ± 0.13[0.005] 4. PLC ± - ANGLES ± -		APVD H ROSE 02MAR94 NAME H ROSE PRODUCT SPEC APPLICATION SPEC		SIZE A1 CAGE CODE 00779 DRAWING NO. C=583861 RESTRICTED TO	
MATERIAL: GLASS FILLED POLYESTER COLOR: BLACK		FINISH: -		WEIGHT: - CUSTOMER DRAWING	
		SCALE: 4:1		SHEET 1 OF 2	
				REV V2	

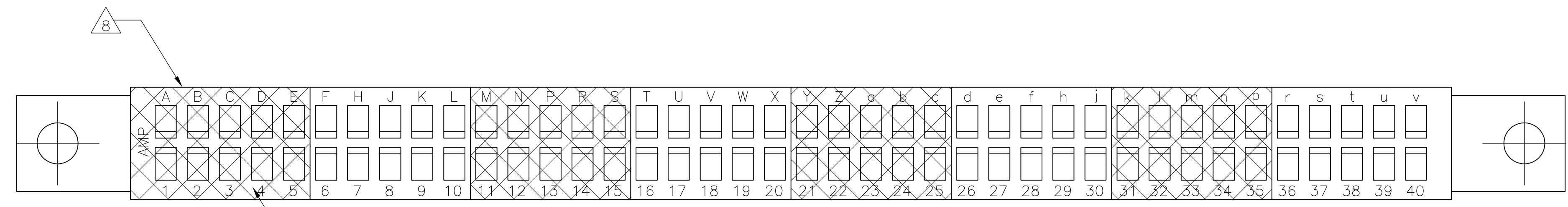

COLOR CODE FIRST FIVE (5) POSITIONS, NEXT FIVE (5) POSITIONS PLAIN, THIRD FIVE (5) POSITIONS, ETC.

1.58±0.38 [.062±.015] MIN CHARACTERS STAMPED IN WHITE INK TWO PLACES

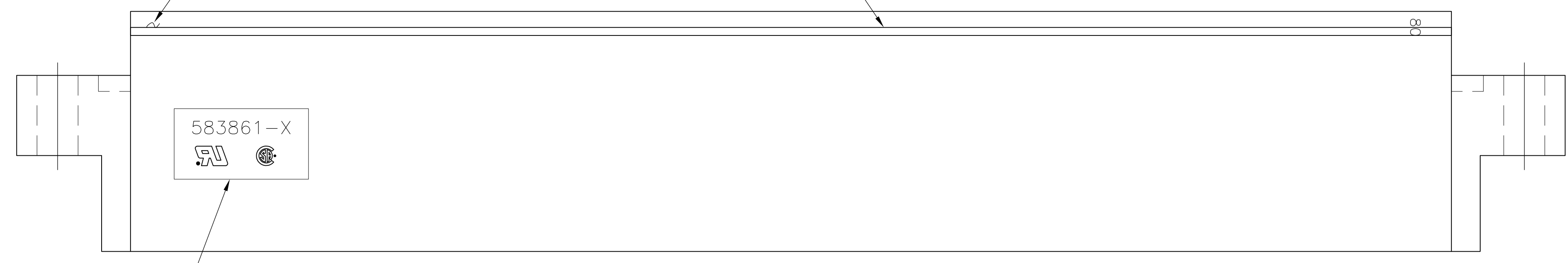

- 1 FIRST 22 POSITIONS MARKED WITH UPPER CASE LETTERS, FOLLOWED BY LOWER CASE LETTERS, FOLLOWED BY UPPERCASE AA,AB,AC ETC. CHARACTERS G,I,O AND Q ARE OMITTED. SEE TABLE FOR END CAVITY IDENTIFICATION.
- 2 OPTIONAL PULL GROOVES. THE PULL GROOVE LENGTH, SIZE AND LOCATION ARE AT THE DISCRETION OF THE MOLD VENDOR.
- 3 HOUSING PART NUMBER, UL & CSA LOGO'S TO BE MOLDED IN THIS AREA. UL, LOGO PER 1-18838-3, CSA LOGO PER 1-18839-3.
- 4 CORING AT AMP'S OPTION REF ONLY.
- 5 SPECIAL MARKING FOR 2-583861-3.
- 6 HIGHLIGHT MOLDED LETTERS AND NUMBERS WITH WHITE INK AT WIRE ONLY ON 2-583861-6.
- 8 DATE CODE TO BE MOLDED IN THIS AREA

	20 & X	71.88	65.41	53.85	58.42	53.34	48.26	20	2-583861-9
		[2.830]	[2.575]	[2.120]	[2.300]	[2.100]	[1.900]		
OBSOLETE	9 & K	43.94	37.47	25.91	30.48	25.40	20.32	9	2-583861-7
		[1.730]	[1.475]	[1.020]	[1.200]	[1.000]	[.800]		
OBSOLETE	SAME AS 2-583861-1 EXCEPT SPECIAL MARKING PER 6								2-583861-6
	36 & r	112.52	106.05	94.49	99.06	93.98	88.90	36	2-583861-5
		[4.430]	[4.175]	[3.720]	[3.900]	[3.700]	[3.500]		
OBSOLETE	SAME AS 583861-3 EXCEPT SPECIAL COLOR CODING 5								2-583861-3
	50 & AF	148.08	141.61	130.05	134.62	129.54	124.46	50	2-583861-1
		[5.830]	[5.575]	[5.120]	[5.300]	[5.100]	[4.900]		
	28 & f	92.20	85.73	74.17	78.74	73.66	68.58	28	1-583861-9
		[3.630]	[3.375]	[2.920]	[3.100]	[2.900]	[2.700]		
	25 & c	84.58	78.11	66.55	71.12	66.04	60.96	25	1-583861-7
		[3.330]	[3.075]	[2.620]	[2.800]	[2.600]	[2.400]		
OBSOLETE	22 & Z	76.96	70.49	58.93	63.50	58.42	53.34	22	1-583861-5
		[3.030]	[2.775]	[2.320]	[2.500]	[2.300]	[2.100]		
OBSOLETE	18 & V	66.80	60.33	48.77	53.34	48.26	43.18	18	1-583861-3
		[2.630]	[2.375]	[1.920]	[2.100]	[1.900]	[1.700]		
	17 & U	64.26	57.79	46.23	50.80	45.72	40.64	17	1-583861-1
		[2.530]	[2.275]	[1.820]	[2.000]	[1.800]	[1.600]		
	15 & S	59.18	52.71	41.15	45.72	40.64	35.56	15	583861-9
		[2.330]	[2.075]	[1.620]	[1.800]	[1.600]	[1.400]		
	10 & L	46.48	40.01	28.45	33.02	27.94	22.86	10	583861-7
		[1.830]	[1.575]	[1.120]	[1.300]	[1.100]	[.900]		
	6 & F	36.32	29.85	18.29	22.86	17.78	12.70	6	583861-5
		[1.430]	[1.175]	[.720]	[.900]	[.700]	[.500]		
	40 & v	122.68	116.21	104.65	109.22	104.14	99.06	40	583861-3
		[4.830]	[4.575]	[4.120]	[4.300]	[4.100]	[3.900]		
	30 & j	97.28	90.81	79.25	83.82	78.74	73.66	30	583861-1
		[3.830]	[3.575]	[3.120]	[3.300]	[3.100]	[2.900]		
	END CAVITY IDENT	F	E	D	C	B	A	POSN	PART NUMBER

THIS DRAWING IS A CONTROLLED DOCUMENT. DWG: J. GALLUCCI, BG. 10DEC92. CHK: H. ROSE. 02MAR94. NAME: H. ROSE. 02MAR94. PRODUCT SPEC: HOUSING, CRIMP SNAP TWIN LEAF, .100 CL. APPLICATION SPEC: RESTRICTED TO: A1 00779. C=583861. WEIGHT: -. SCALE: 4:1. SHEET: 2 OF 2. REV: V2.