



Chipsmall Limited consists of a professional team with an average of over 10 year of expertise in the distribution of electronic components. Based in Hongkong, we have already established firm and mutual-benefit business relationships with customers from,Europe,America and south Asia,supplying obsolete and hard-to-find components to meet their specific needs.

With the principle of "Quality Parts,Customers Priority,Honest Operation,and Considerate Service",our business mainly focus on the distribution of electronic components. Line cards we deal with include Microchip,ALPS,ROHM,Xilinx,Pulse,ON,Everlight and Freescale. Main products comprise IC,Modules,Potentiometer,IC Socket,Relay,Connector.Our parts cover such applications as commercial,industrial, and automotives areas.

We are looking forward to setting up business relationship with you and hope to provide you with the best service and solution. Let us make a better world for our industry!



Contact us

Tel: +86-755-8981 8866 Fax: +86-755-8427 6832

Email & Skype: info@chipsmall.com Web: www.chipsmall.com

Address: A1208, Overseas Decoration Building, #122 Zhenhua RD., Futian, Shenzhen, China



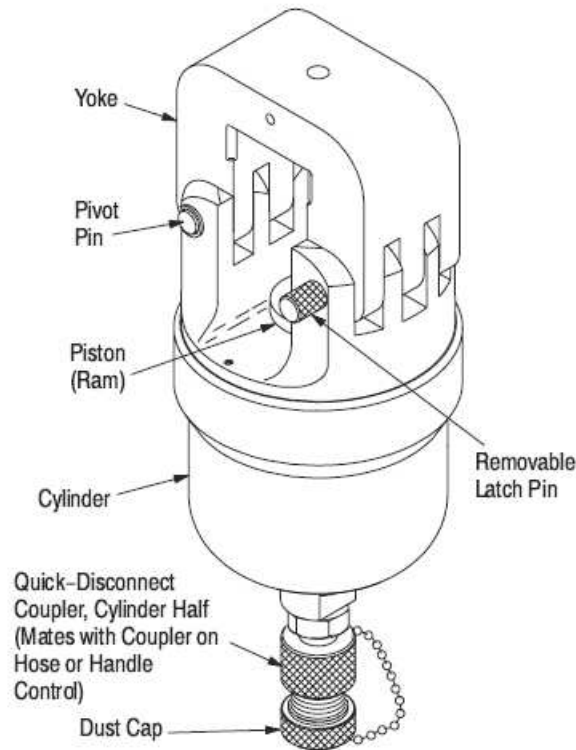

NOTE

Recommended ONLY for use with Hydraulic Power Unit 69120-1 (115VAC), 69120-2 (230VAC), and Hydraulic Hand Pump 314979-1. This head crimps SOLISTRAND* terminals (250-600 MCM).

Figure 1

1. INTRODUCTION

This instruction sheet covers application and maintenance procedures for Hydraulic Crimping Head 58445-1 shown in Figure 1. The crimping head will accept interchangeable die sets for a variety of heavy-duty terminals and splices for large wire sizes within the range of 250 MCM through 600 MCM (thousand circular mils). Refer to the instructions packaged with specific die sets for compatible products, wire ranges, strip dimensions, and application procedures.

This crimping head is designed for two DYNA-CRIMP* tools: either Hydraulic Hand Pump 314979-1 specified in Customer Manual 409-5860; or Hydraulic Power Unit 69120-[] specified in Customer Manual 409-1950.

Warning: To avoid personal injury and potential damage to the crimp head, TE Connectivity (TE) requires the crimp head to operate at 8,000 to 8,400 PSI [552 to 579 bar]. TE recommends using 8,200 PSI [565 bar] TE Hydraulic Pumps as other manufacturers' pumps may apply insufficient pressure (resulting in an inadequate crimp) or excessive pressure (resulting in failure of the head). Additionally, the TE pump must be used to maintain CE certification; if using other manufacturers' pumps, the user is responsible for self-certification.

Read these instructions and other applicable references carefully before proceeding.



NOTE

Dimensions in this instruction sheet are in millimeters [with inches in brackets]. Illustrations and figures are for reference only and are not drawn to scale.

Reasons for reissue of this Instruction Sheet are provided in Section 8; REVISION SUMMARY

2. DESCRIPTION

Main components of the crimping head are: a yoke which houses the stationary die and retains the terminal assembly for crimping, a removable latch pin which allows pivoting of the yoke on the pivot pin (typically required for splice terminations), a cylinder which contains the head's hydraulic chamber, a piston (ram) which holds and controls the moving die, and a quick connect/disconnect coupler (cylinder half) which mates with the coupler on hose or handle control to release or supply pressure.



DANGER

To avoid injury when using DYNA-CRIMP equipment, observe the following precautions:

- DO NOT modify the crimping equipment in any way.
- USE ONLY dies, terminals, and wire specified for the head.
- DO NOT perform repairs other than those specified in the instructional material supplied with the equipment.

3. CRIMPING HEAD INSTALLATION

Each crimping head is shipped with a coating of lubricating oil to prevent rust and corrosion. Wipe the oil off before installing the crimping head on the power unit. Note that the crimping head is shipped without oil inside the cylinder. To install crimping head, proceed as follows:



DANGER

Verify that the hydraulic pressure to hose or handle control is released and that power supply is disconnected from electric power unit, if applicable.

1. Remove protective dust caps from both quick connect/disconnect couplers.
2. Hold hose or handle control in vertical position to prevent oil spillage. Attach hose or handle control to coupling section on head. **THREAD PROPERLY AND TIGHTEN SECURELY.**



CAUTION

Oil flow must be unobstructed between power unit and crimping head. Verify that all couplers are fully mated and tightened.



NOTE

If crimping head must be removed after being in production, pressure must be released in the hydraulic system before head is removed.

- If using Hydraulic Power Unit 69120-[], disconnect power unit from power supply.
- If using Hydraulic Hand Pump 314979-1, depress pressure release lever.

4. DIE INSERTION AND REMOVAL (FIGURE 2)



DANGER

Use extreme care when operating power unit. DO NOT inadvertently actuate the tool when installing or changing dies. Personal injury could result.

Verify that matched die set, terminal, and wire size are compatible. With crimping head properly installed, refer to die set instructions, and insert/change die set as follows:

1. Remove latch pin and open yoke on crimping head.
2. Loosen setscrew in yoke. Refer to die set instructions and insert stationary (upper) die, which includes the nest area, into well of yoke. Tighten setscrew.
3. Activate power unit to advance ram until setscrew is visible (about 12.7 mm [.500 in.]). Loosen setscrew.
4. Insert moving (lower) die (which serves as the indenter) into ram well, making sure moving die is properly oriented to mate with stationary die. Tighten setscrew.
5. Close yoke and secure with latch pin.
6. Slowly close dies to ensure proper alignment.
7. Complete the cycle and return the ram to the "DOWN" position.

Typical Installation

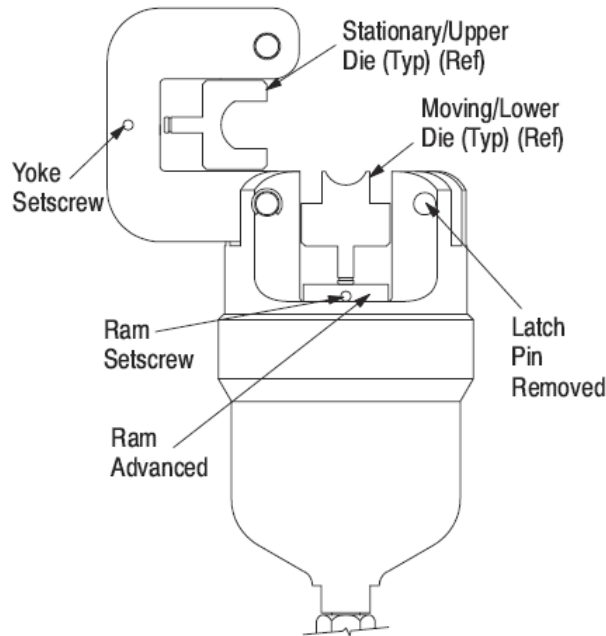

Figure 2

5. CRIMPING PROCEDURE

The following crimping procedure provides general information. Refer to instructions packaged with individual die sets for specific products, wire sizes, strip dimensions, positioning of terminals and splices in the dies, and crimping procedures.



DANGER

To prevent personal injury when operating the power unit, exercise caution while holding terminals or wire near crimping area.

1. Insert terminal or splice in the stationary (upper) die according to instructions with the dies. Verify the latch pin is secure before activating the power unit.
2. Inspect pivot pin holes and latch pin holes for wear. Replace parts, as needed.
3. Activate power unit. Raise ram to “UP” position. Inspect flat and round surfaces of ram for galling (fretting or wear by friction), cracks, or oil leakage. Release pressure and make sure ram retracts smoothly.
4. Cycle tool to complete crimp. Remove crimped terminal or splice.



NOTE

If the splice or terminal sticks in the die after crimping, apply a rocking action to release it.

6. MAINTENANCE AND INSPECTION



DANGER

Verify hydraulic pressure is released and power supply is disconnected before following maintenance and inspection procedures, unless otherwise specified in the procedure.

Each crimping head is assembled and inspected before shipment. TE Connectivity recommends that the crimping head be inspected immediately upon its arrival at the facility of use, and at regularly scheduled intervals, to ensure the head has not been damaged during handling and use. Frequency of inspection depends upon the following: care, amount of use, and handling of the head; type and size of products crimped; degree of operator skill; and environmental conditions.

6.1. Cleaning

Remove accumulations of dirt and grease on the crimping head; especially in areas where dies are installed and terminals are crimped. Clean the entire head frequently with a clean, lint-free cloth.

6.2. Visual Inspection

Refer to Figure 3 and proceed as follows:

1. With hydraulic pressure released, inspect the assembled head for nicks, scratches, and cracks. Inspect for cracks especially at the corners of the yoke and around the top of the cylinder.

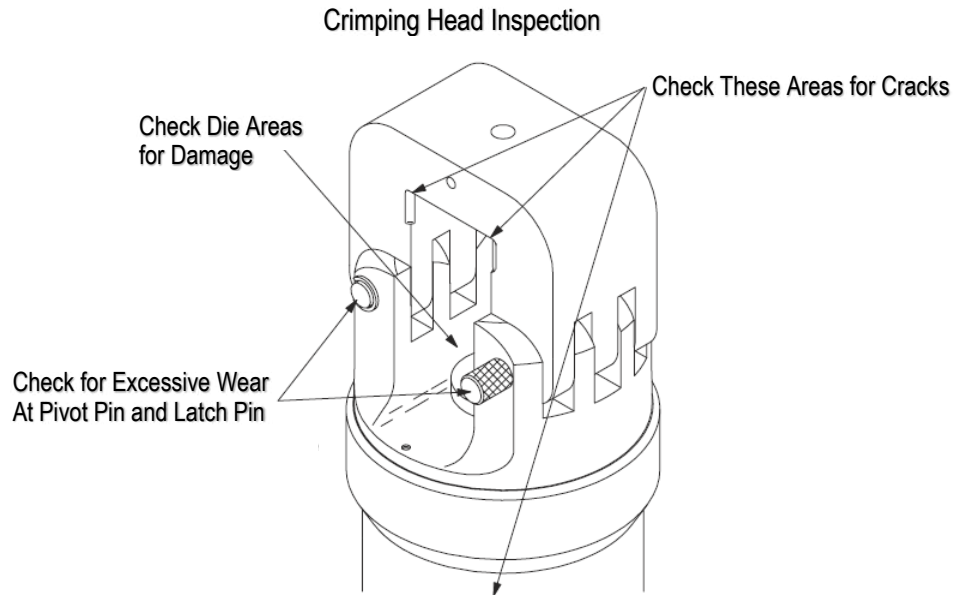

Figure 3

2. Inspect pivot pin holes and latch pin holes for wear. Replace parts, as needed.
3. Activate power unit. Raise ram to "UP" position. Inspect flat and round surfaces of ram for galling (fretting or wear by friction), cracks, or oil leakage. Release pressure and make sure ram retracts smoothly.
4. If head shows evidence of galling, cracks, oil leakage, or rough cycling, return the crimping head to TE for repairs. Refer to Paragraph 7, REPLACEMENT PARTS AND REPAIRS.



NOTE

Once per year, or every 7,500 cycles (whichever comes first), the hydraulic head should be returned to TE for magnetic particle inspection. Additionally, inspect and service the head (as described in Figure 3) every month or 1,000 cycles. Refer to Instruction Sheet 408-8909.

6.3. Crimping Head Check-Out Procedure

If the ram fails to return to the "DOWN" position after completion of a crimping cycle, the cause may be in the crimping head. To determine whether or not the trouble is in the crimping head, proceed as follows:

With Hydraulic Power Unit 69120-[]

With power unit activated, press the pressure release button on the electrical control box. Or, if the unit has the "dump" feature, move the trigger to the "dump" position and hold for several seconds (this will release any pressure in the hydraulic system). If the ram returns to "DOWN" position, the trouble is not in the crimping head. If the ram does not return, verify the coupler is fully engaged. If coupler is fully engaged and ram still does not go "DOWN", return the crimping head to TE for repairs.

With Hydraulic Hand Pump 314979-1

With power unit activated, press the "return" lever. If the ram fails to return to "START" or "DOWN" position, return the crimping head to TE for repairs.

7. REPLACEMENT PARTS AND REPAIRS

Customer-replaceable parts are listed in Figure 4. A complete inventory should be stocked and controlled to prevent lost time when replacement of parts is necessary. Order parts through your TE Representative or call 1-800-526-5142, or send a facsimile of your purchase order to 1-717-986-7605, or write, or return the entire tool for evaluation and repair, with a written description of the problem to:

CUSTOMER SERVICE (38-35)
 TE CONNECTIVITY CORPORATION
 P.O. BOX 3608
 HARRISBURG, PA 17105-3608

Tools may also be returned for evaluation and repair. For tool repair service, contact a TE Representative at 1-800-526-5136.

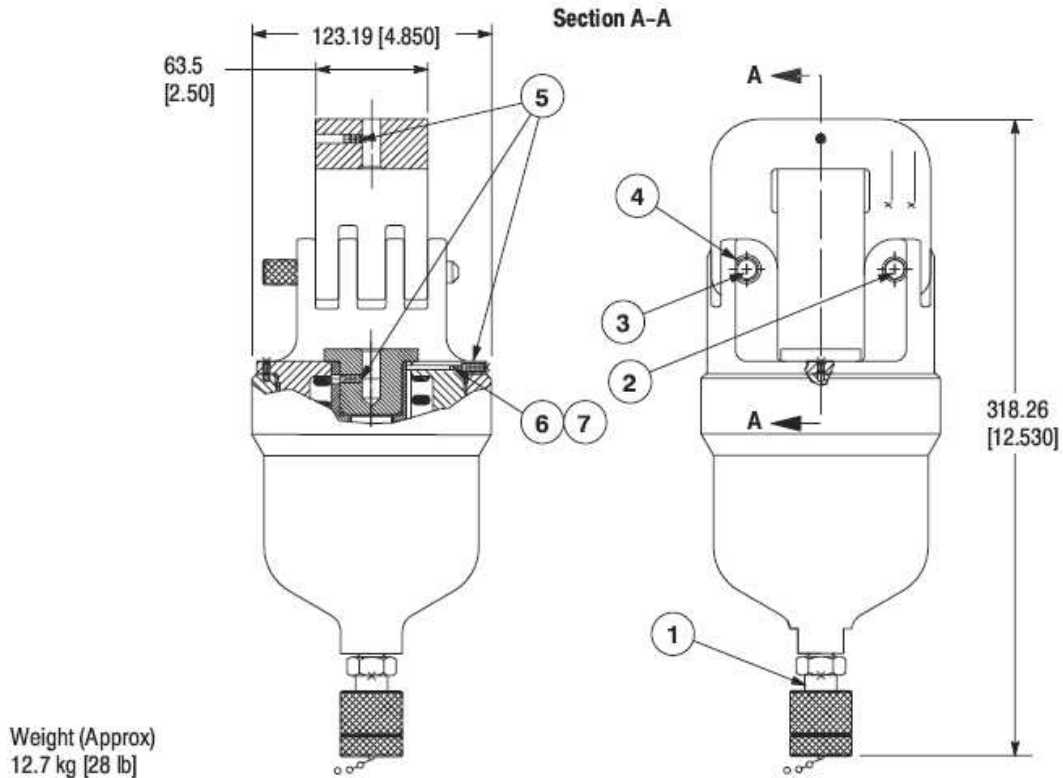

Item	Part Number	Description	Quantity
1	311471-1	Coupler, Quick Connect/Disconnect	1
2	306209-8	Pin, Removable Latch	1
3	8-59558-5	Pin, Pivot	1
4	1-21045-1	Ring, Retaining	1
5	4-21012-0	Setscrew	3
6	4-23147-7	Spring, Compression	1
7	1-21919-6	Pin, Dowel	1

Figure 4

8. REVISION SUMMARY

- Added Warning (paragraph 1)
- Added NOTE after paragraph 6.2.4. specifying return to TE for magnetic particle inspection