



Chipsmall Limited consists of a professional team with an average of over 10 year of expertise in the distribution of electronic components. Based in Hongkong, we have already established firm and mutual-benefit business relationships with customers from,Europe,America and south Asia,supplying obsolete and hard-to-find components to meet their specific needs.

With the principle of “Quality Parts,Customers Priority,Honest Operation,and Considerate Service”,our business mainly focus on the distribution of electronic components. Line cards we deal with include Microchip,ALPS,ROHM,Xilinx,Pulse,ON,Everlight and Freescale. Main products comprise IC,Modules,Potentiometer,IC Socket,Relay,Connector.Our parts cover such applications as commercial,industrial, and automotives areas.

We are looking forward to setting up business relationship with you and hope to provide you with the best service and solution. Let us make a better world for our industry!



## Contact us

Tel: +86-755-8981 8866 Fax: +86-755-8427 6832

Email & Skype: info@chipsmall.com Web: www.chipsmall.com

Address: A1208, Overseas Decoration Building, #122 Zhenhua RD., Futian, Shenzhen, China



**PROPER USE GUIDELINES**

Cumulative Trauma Disorders can result from the prolonged use of manually powered hand tools. Hand tools are intended for occasional use and low volume applications. A wide selection of powered application equipment for extended-use, production operations is available.

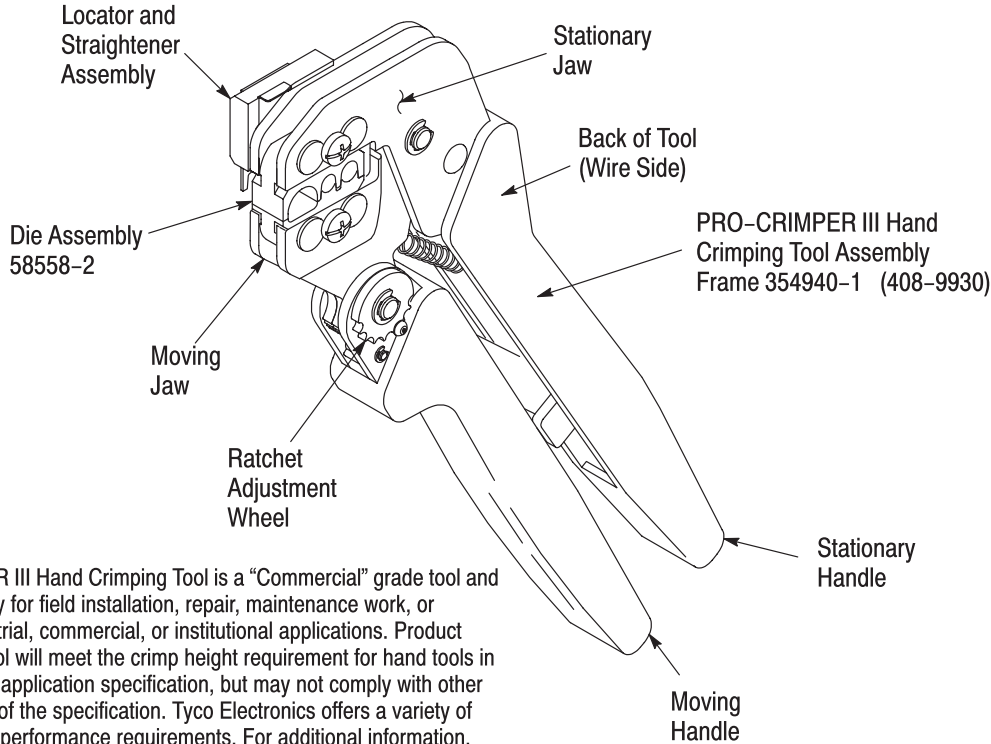

The PRO-CRIMPER III Hand Crimping Tool is a “Commercial” grade tool and is designed primarily for field installation, repair, maintenance work, or prototyping in industrial, commercial, or institutional applications. Product crimped with this tool will meet the crimp height requirement for hand tools in the appropriate 114 application specification, but may not comply with other feature parameters of the specification. Tyco Electronics offers a variety of tools to satisfy your performance requirements. For additional information, contact the Technical Assistance Center at 1-800-722-1111.

Figure 1

**1. INTRODUCTION**

PRO-CRIMPER III Hand Crimping Tool Assembly 58558-1 consists of Die Assembly 58558-2 and PRO-CRIMPER III Hand Crimping Tool Frame 354940-1. The hand tool assembly is used to crimp Consumer RF Series BNC Plug Connectors onto various sizes of RG/U cable.

For additional information on the hand tool frame, refer to 408-9930.

Read these instructions thoroughly before using the hand tool assembly.

**NOTE**  
 *Dimensions on this sheet are in millimeters [with inches in brackets]. Figures are not drawn to scale.*

Reasons for reissue are provided in Section 9, REVISION SUMMARY.

**2. DESCRIPTION** (Figures 1 and 2)

The hand tool assembly features a tool frame with a stationary jaw and handle, a moving jaw, a moving handle, and an adjustable ratchet that ensures full contact crimping. The tool frame holds a die assembly with four crimping chambers. The die assembly features an indenter die and an anvil die.

Attached to the outside of the frame is a locator and straightener assembly, which properly positions and holds the connector center contact during crimping.

Die retaining pins and die retaining screws are used to position and secure the dies in the tool frame. A nut is used on the upper die retaining screw to hold the locator and straightener assembly in place.

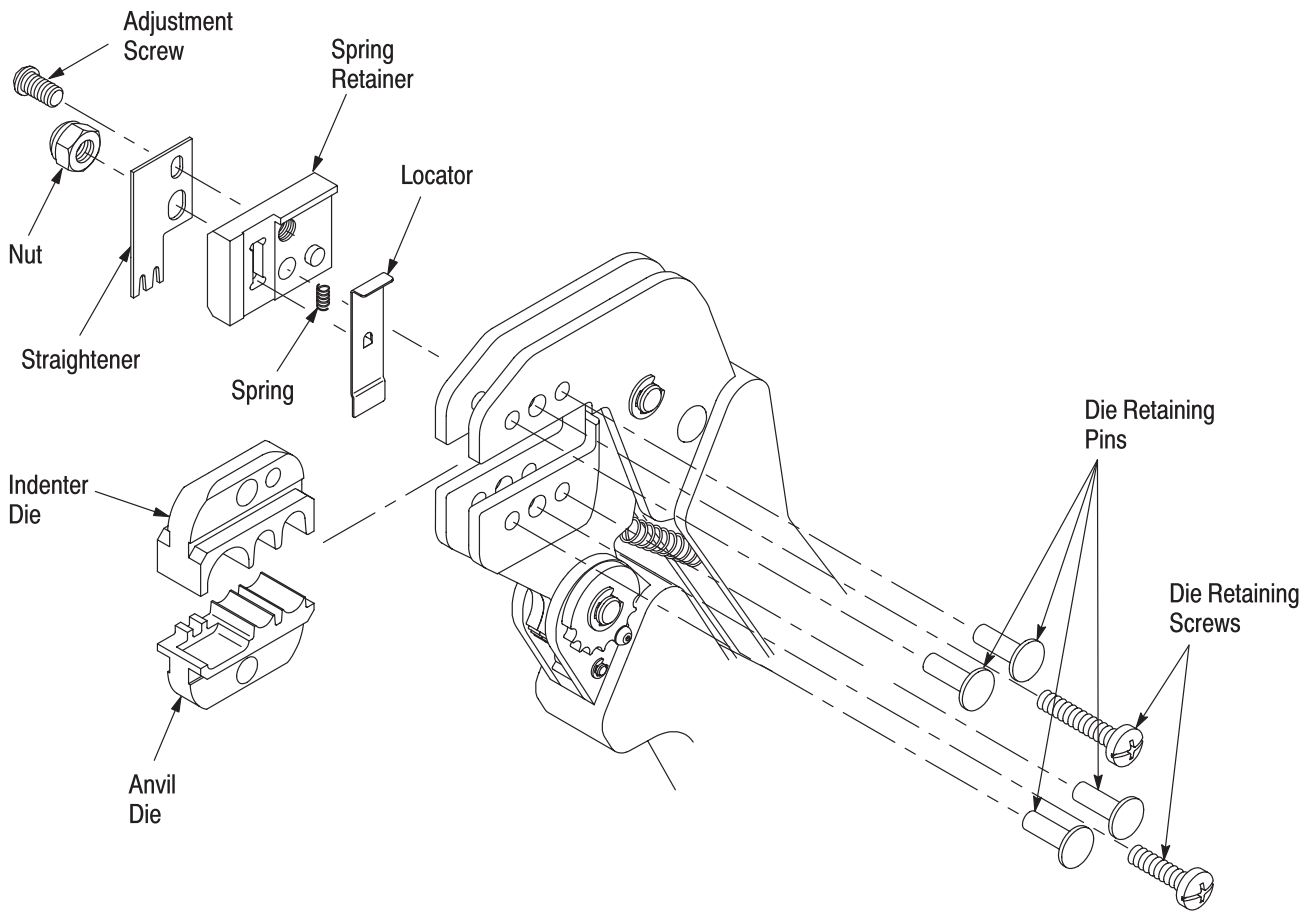

Figure 2

**3. INSTALLATION AND REMOVAL OF DIE ASSEMBLY AND LOCATOR AND STRAIGHTENER ASSEMBLY**  
(Figure 2)

1. Close the tool handles until the ratchet releases, then allow the handles to open fully.
2. Remove the two die retaining screws from the tool jaws.
3. Install the anvil die in the movable jaw of the tool frame. Insert the short die retaining screw through the retaining hole in the jaw and through the anvil die. Tighten the screw just enough to hold the die in place. Do *not* tighten the screw completely at this time.
4. Install the indenter die in the stationary jaw of the tool frame. Insert the long die retaining screw through the retaining hole in the jaw and through the indenter die. Tighten the screw just enough to hold the die in place. Do *not* tighten the screw completely at this time.
5. Carefully close the tool handles, making sure that the dies align properly. Continue closing the tool handles until the ratchet in the tool frame has

engaged sufficiently to hold the dies in place, then tighten both die retaining screws.



*The ratchet has detents that create audible clicks as the tool handles are closed.*

6. Attach the straightener onto the spring retainer with the adjustment screw. Insert the spring into the spring retainer and place the locator over the spring.
7. While holding the locator against the spring retainer, place the screw hole in the spring retainer over the end of the long die retaining screw. The locator should be against the side of the tool jaw.
8. Place the nut onto the end of the long die retaining screw and tighten the nut enough to hold the locator and straightener assembly in place, but still allowing the locator to slide up and down.
9. To disassemble, close the tool handles until the ratchet releases. Remove the nut, the locator and straightener assembly, and the two die retaining screws. Slide the anvil and indenter out of the tool jaws.

**4. CRIMPING PROCEDURE**

**NOTE** *This tool is provided with a center contact support adjustment and a connector retention force forceadjustment feature. Initially, the center contact support and the retention force should be verified as specified in Section 5, CENTER CONTACT SUPPORT ADJUSTMENT, and Section 6, RETENTION FORCE ADJUSTMENT, before using the tool to crimp desired connectors.*

For detailed information on cable strip lengths and proper assembly of the connector, refer to the instructions packaged with the connector. Make sure that the connector ferrule has been placed onto the cable, and that the cable braided shield is flared away from the cable. Then proceed as described in 4.1, and 4.2.

**4.1. Crimping the Center Contact** (Figure 3)

1. Holding the center contact by the mating end, insert the contact through the front of the tool and into the appropriate crimping chamber of the anvil die.
2. Close the tool handles so that the dies partially close. Position the contact so that the locator drops into the contact wire stop slot and the end of the contact is inside the groove in the straightener. See cross-sectional view in Figure 3.
3. Hold the contact in place and squeeze the tool handles together until the ratchet engages just enough to hold the contact in place. Do not deform the contact wire barrel.

4. Insert stripped cable into contact wire barrel until it is butted against the locator. See cross-sectional view in Figure 3.

**CAUTION** *Make sure that both sides of the wire barrel are started evenly into the crimping chamber. Do NOT attempt to crimp an improperly positioned center contact.*

5. Holding the cable in position, close the tool handles until the ratchet releases. Allow the tool handles to open fully and remove the crimped center contact from the dies.

**NOTE** *The crimped center contact may stick in the crimping area, but the contact can be easily removed by pushing downward on the top of the locator (see Figure 3).*

**4.2. Crimping the Ferrule** (Figure 4)

1. Insert the crimped center contact into the connector body until the cable dielectric butts against the dielectric inside the connector body or until the center contact is securely positioned within the connector. Make sure that the braided shield is over the support sleeve of the connector body and that no strands from the shield enter the connector body.
2. Slide the ferrule up over the braided shield and onto the connector until the ferrule butts against the shoulder on the connector body.
3. Place the ferrule in the appropriate crimping chamber of the anvil die so that the shoulder on the connector body butts against the edge of the die.

**Center Contact Crimp**

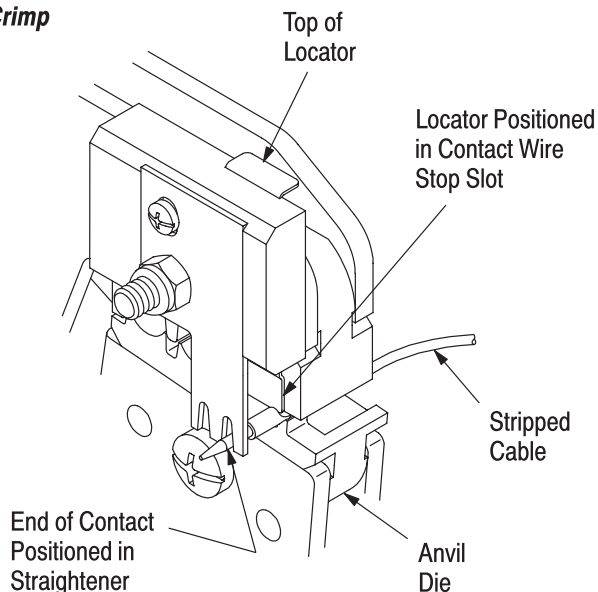

**Cross-Sectional View**

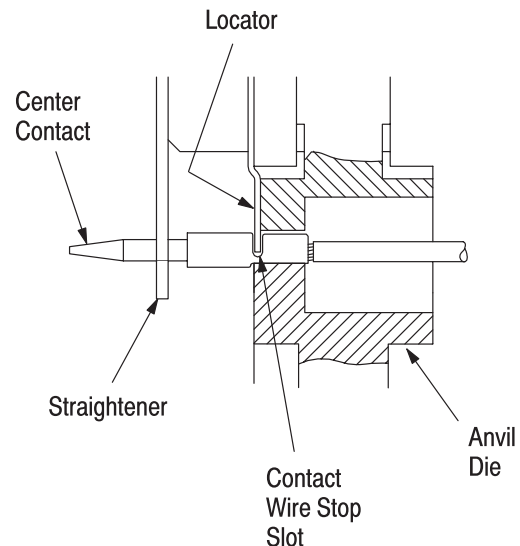

Figure 3

**Ferrule Crimp**

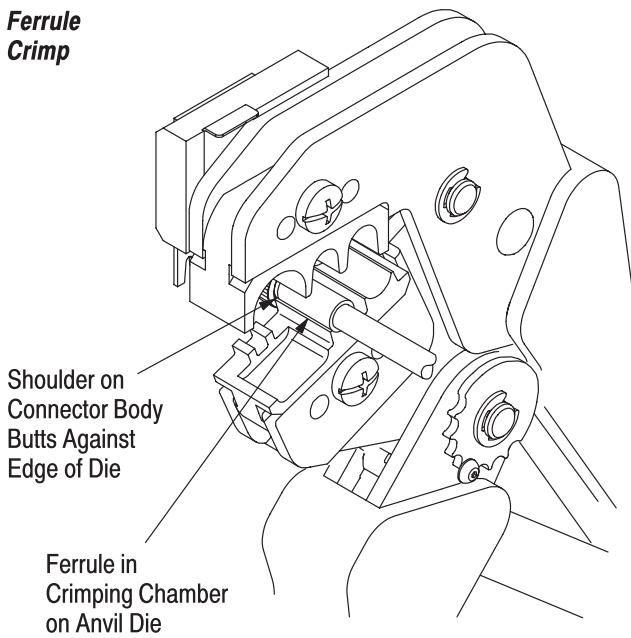

Figure 4



Refer to the instruction sheet packaged with the connector to determine the appropriate crimping chamber for the ferrule.

4. While holding the assembly together, begin to close the tool handles. Keep holding the assembly until the dies have closed enough to hold the assembly in place.
5. Carefully close the tool handles until the ratchet releases.
6. Allow the tool handles to open fully and remove the crimped connector from the dies.

**5. CENTER CONTACT SUPPORT ADJUSTMENT**

Make a sample crimp and determine if the center contact is bending upward, bending downward, or bending from side to side. If the contact is bent, adjustment is required.

1. Loosen the adjustment screw.
2. Place a center contact with cable into the proper crimping chamber and close the tool handles until the locator and straightener assembly is holding the contact in position.
3. Move the straightener up or down, as required, to eliminate the bending of the center contact.
4. Tighten the adjustment screw and close the handles until the ratchet releases.

5. Remove and inspect the center contact.
6. Make another sample crimp. If the contact is still being bent during crimping, repeat the adjustment procedure.

**6. RATCHET ADJUSTMENT** (Figure 5)

The frame assembly ratchet mechanism features an adjustment wheel with numbered settings. If the crimp height or retention force is not acceptable, adjust the ratchet as follows:



Refer to the appropriate application specification (114-series document) for the required retention force for the connector.

1. Remove the lock screw from the ratchet adjustment wheel.
2. With a screwdriver, adjust the ratchet wheel from the opposite side of the frame.
3. Observe the ratchet adjustment wheel. If a tighter crimp is required, rotate the adjustment wheel COUNTERCLOCKWISE to a higher-numbered setting. If a looser crimp is required, rotate the adjustment wheel CLOCKWISE to a lower-numbered setting.
4. Replace the lock screw.
5. Make a sample crimp and measure the crimp height. If the crimp height is acceptable, secure the lock screw. If the dimension is unacceptable, remove lock screw and continue to adjust the ratchet, and again measure a sample crimp.

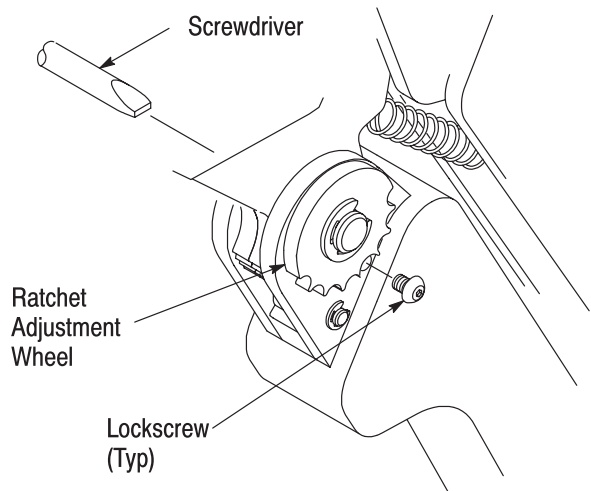

Figure 5

**7. MAINTENANCE AND INSPECTION**

**7.1. Maintenance**

1. Remove dust, moisture, and other contaminants with a clean, soft brush, or a clean, soft, lint-free cloth. Do NOT use any objects that could damage the dies or tool.
2. Make sure that the proper die retaining screws are properly secured.
3. When the dies are not in use, mate and store them in a clean, dry area.
4. Store the tool with the tool handles closed to prevent objects from becoming lodged within the jaws.

**7.2. Inspection**

1. Remove all lubrication and accumulated film from the dies by immersing the dies in a suitable commercial degreaser.
2. Make certain that all die retaining screws and die components are properly secured.
3. Inspect the crimping surfaces for flattened, chipped, worn, or cracked areas. If damage is evident, the dies must be replaced. Refer to Section 8, DIE REPLACEMENT.

**7.3. Measuring the Die Opening**

The die assembly will perform correctly as long as: (1) the product specified is correct for the application, (2) the specific die assembly is used, (3) the die assembly has been measured to ensure that the openings are correct, and (4) the tool has been adjusted correctly. Figure 6 provides information on die opening sizes.

**8. REPLACEMENT**

Customer-replaceable parts are shown in Figure 1.

Available separately, PRO-CRIMPER III Hand Crimping Tool Repair Kit 679221-1 includes a replacement nut and a variety of pins, rings, screws, and springs.

If the dies are damaged or worn excessively, they must be replaced. Order the repair kit and replaceable parts through your Tyco Electronics representative, or call 1-800-526-5142, or send a facsimile of your purchase order to 1-717-986-7605, or write to:

CUSTOMER SERVICE (38-35)  
 TYCO ELECTRONICS  
 PO BOX 3608  
 HARRISBURG PA 17105-3608

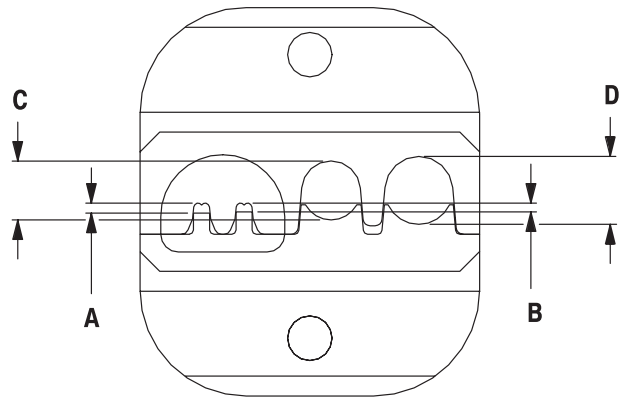

**Note:** Not to Scale

DIE CLOSURE DIMENSIONS ( $\pm 0.10$ ( $\pm .004$ ))			
A	B	C	D
0.89 [.035]	0.79 [.031]	5.28 [.208]	6.10 [.240]

Figure 6

**9. REVISION SUMMARY**

Since the previous of this instruction sheet, the following changes were made:

- PRO-CRIMPER II Hand Tool was changed to PRO-CRIMPER III Hand Tool,
- The TE logo was applied, and
- The format was updated to the current corporate requirements.