



Chipsmall Limited consists of a professional team with an average of over 10 year of expertise in the distribution of electronic components. Based in Hongkong, we have already established firm and mutual-benefit business relationships with customers from,Europe,America and south Asia,supplying obsolete and hard-to-find components to meet their specific needs.

With the principle of “Quality Parts,Customers Priority,Honest Operation,and Considerate Service”,our business mainly focus on the distribution of electronic components. Line cards we deal with include Microchip,ALPS,ROHM,Xilinx,Pulse,ON,Everlight and Freescale. Main products comprise IC,Modules,Potentiometer,IC Socket,Relay,Connector.Our parts cover such applications as commercial,industrial, and automotives areas.

We are looking forward to setting up business relationship with you and hope to provide you with the best service and solution. Let us make a better world for our industry!



## Contact us

Tel: +86-755-8981 8866 Fax: +86-755-8427 6832

Email & Skype: info@chipsmall.com Web: www.chipsmall.com

Address: A1208, Overseas Decoration Building, #122 Zhenhua RD., Futian, Shenzhen, China



**PROPER USE GUIDELINES**

Cumulative Trauma Disorders can result from the prolonged use of manually powered hand tools. Hand tools are intended for occasional use and low volume applications. A wide selection of powered application equipment for extended-use, production operations is available.

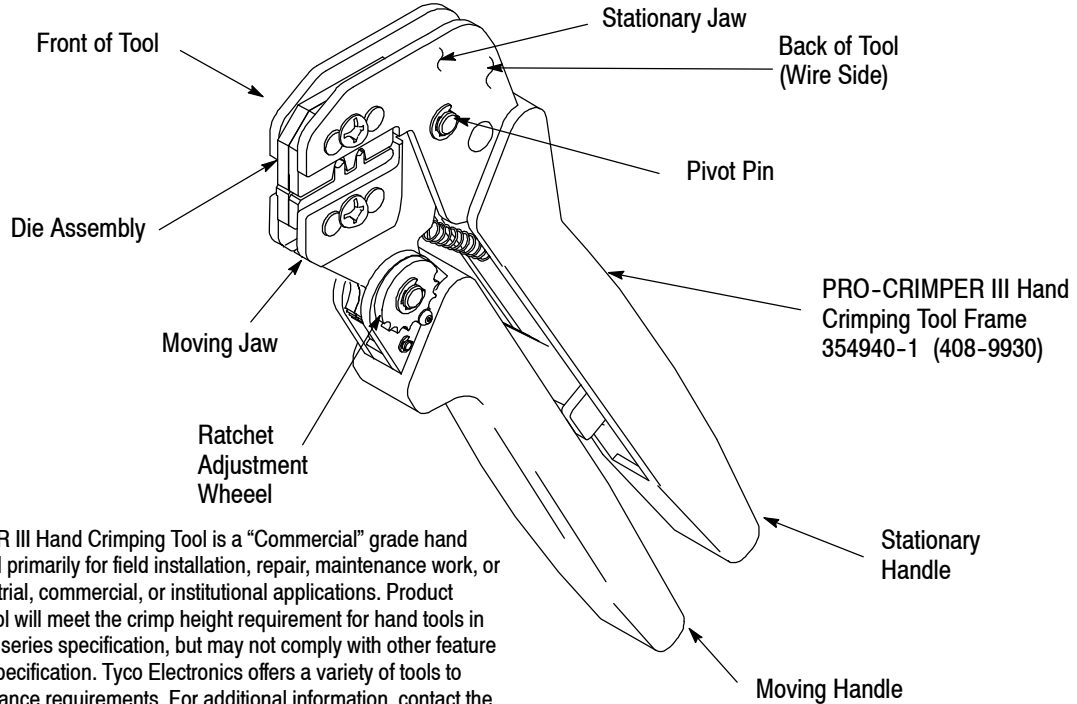

The PRO-CRIMPER III Hand Crimping Tool is a “Commercial” grade hand tool and is designed primarily for field installation, repair, maintenance work, or prototyping in industrial, commercial, or institutional applications. Product crimped with this tool will meet the crimp height requirement for hand tools in the appropriate 114 series specification, but may not comply with other feature parameters of the specification. Tyco Electronics offers a variety of tools to satisfy your performance requirements. For additional information, contact the Tooling Assistance Center at 1-800-722-1111.

TE Die Assembly	Contact Family†	Wire		
		Size (AWG)	Insul Dia	Strip Length mm [In.]
58561-2	.250 FASTON* Receptacle	22-18	2.29 to 3.30 [.090 to .130]	4.75 [.187]

† Supplied with die assembly. Also available separately..

‡ Contact the TOOLING ASSISTANCE CENTER or PRODUCT INFORMATION (see below) for specific contact part numbers.

Figure 1

**1. INTRODUCTION**

PRO-CRIMPER III Hand Crimping Tool Assembly 58562-1 consists of Die Assembly 58562-2 and PRO-CRIMPER III Hand Crimping Tool Frame 354940-1. The die assembly consists of wire and insulation crimping dies.

Read these instructions thoroughly before crimping any terminals.

Reasons for reissue are provided in Section 10, REVISION SUMMARY.

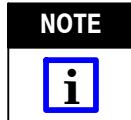

*Dimensions on this sheet are in millimeters [with inch equivalents provided in brackets]. Figures and illustrations are for identification only and are not drawn to scale.*

**2. DESCRIPTION** (Figures 1 and 2)

The tool features a tool frame with a stationary jaw and handle, a moving jaw, a moving handle, and an adjustable ratchet that ensures full contact crimping. The tool frame holds a die assembly with two crimping sections.

The die assembly features a wire anvil, an insulation anvil, a wire crimper, and an insulation crimper.

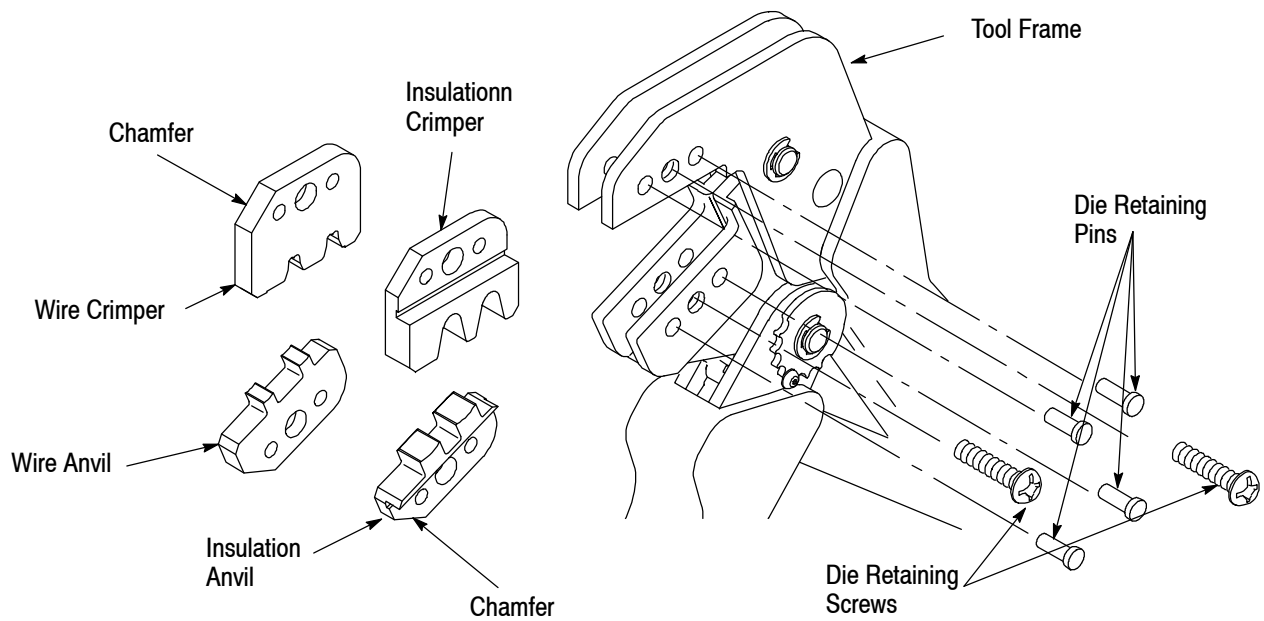

Figure 2

Die retaining pins and die retaining screws are used to position and secure the dies in the tool frame.

**3. INSTALLATION AND REMOVAL OF DIE SET** (Figure 2)

1. Open the tool handles and remove the two die retaining screws from the tool jaws.
2. Place the wire anvil and insulation anvil so that their chamfered sides and their marked surfaces face outward, when mounted in the moving jaw of the tool frame.
3. Insert the two die retaining pins.
4. Insert a die retaining screw through the jaw and through both anvil dies, and tighten the screw just enough to hold the dies in place. Do *not* tighten the screw completely at this time.
5. Place the wire crimper and insulation crimper so that their chamfered sides and their marked surfaces face outward, when mounted in the stationary jaw of the tool frame.
6. Insert the two die retaining pins.
7. Insert a die retaining screw through the jaw and through both crimper dies, and tighten the screw just enough to hold the dies in place. Do *not* tighten the screw completely at this time.
8. Carefully close the tool handles, making sure that the anvils and crimpers align properly. Continue closing the tool handles until the ratchet in the tool frame has engaged sufficiently to hold the anvils and crimpers in place, then tighten both die retaining screws.

9. To disassemble, close the tool handles until the ratchet releases, remove the two die retaining screws and the four die retaining pins, and slide the anvils and crimpers out of the tool jaws.

**4. CRIMPING PROCEDURE**

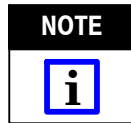

*This tool is provided with a crimp adjustment feature. Initially, the crimp height should be verified as specified in Figure 4. Refer to Section 5, CRIMP HEIGHT INSPECTION, and Section 6, RATCHET (Crimp Height) ADJUSTMENT, to verify crimp height before using the tool to crimp desired terminals and wire sizes.*

Refer to the table in Figure 1 and select wire of the specified size and insulation diameter. Strip the wire to the length indicated in Figure 1, taking care not to nick or cut wire strands. Select an applicable terminal and identify the appropriate crimp section according to the wire size markings on the tool. Refer to Figure 3 and proceed as follows:

1. Hold the tool so that the back (wire side) is facing you. Squeeze tool handles together and allow them to open fully.
2. Holding the terminal by the mating end, insert the terminal — insulation barrel first — through the front of the tool and into the appropriate crimp section.
3. Position the terminal so that the mating end of the terminal is on the front side of the tool, and so that the open “U” of the wire and insulation barrels face the top of the tool. Place the terminal up into the nest.

4. Rotate the tool sufficiently to be able to view the front side of the wire crimper, and position the terminal so that the front edge of the wire barrel is even with the front edge of the wire crimper, as shown in Figure 3.

9. Check the terminal's crimp height as described in Section 5, CRIMP HEIGHT INSPECTION. If necessary, adjust the crimp height as described in Section 6, RATCHET (Crimp Height) ADJUSTMENT.



**CAUTION** Make sure that both sides of the insulation barrel are started evenly into the crimping section. Do NOT attempt to crimp an improperly positioned terminal.

5. Hold the terminal in position and squeeze the tool handles together until ratchet engages sufficiently to hold the terminal in position. Do NOT deform insulation barrel or wire barrel.

6. Rotate the tool so that the back (wire side) is once again facing you.

7. Insert stripped wire into terminal insulation and wire barrels until the end of the wire is even with the edge of the wire barrel and wire crimper, as shown in Figure 3.

8. Holding the wire in place, squeeze tool handles together until ratchet releases. Allow tool handles to open and remove crimped terminal.

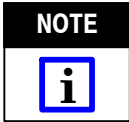

**NOTE** The crimped terminal may stick in the crimping area, but the terminal can be easily removed by pushing downward on the mating end of the terminal.

**5. CRIMP HEIGHT INSPECTION**

Crimp height inspection is performed through the use of a micrometer with a modified anvil, commonly referred to as a crimp-height comparator. Tyco Electronics does not manufacture or market crimp-height comparators. Detailed information on obtaining and using crimp-height comparators can be found in instruction sheet 408-7424.

Proceed as follows:

1. Refer to Figure 4 and select a wire (maximum size) for each crimp section listed.
2. Refer to Section 4, CRIMPING PROCEDURE, and crimp the contact(s) accordingly.
3. Using a crimp height comparator, measure the wire barrel crimp height as shown in Figure 4. If the crimp height conforms to that shown in the table, the tool is considered dimensionally correct. If not, the tool must be adjusted. Refer to Section 6, RATCHET (Crimp Height) ADJUSTMENT.

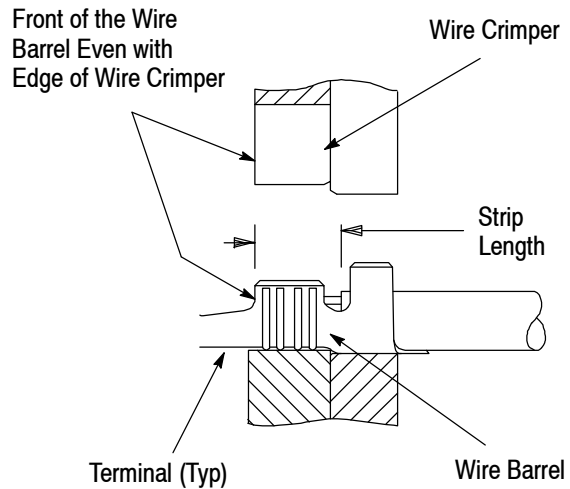
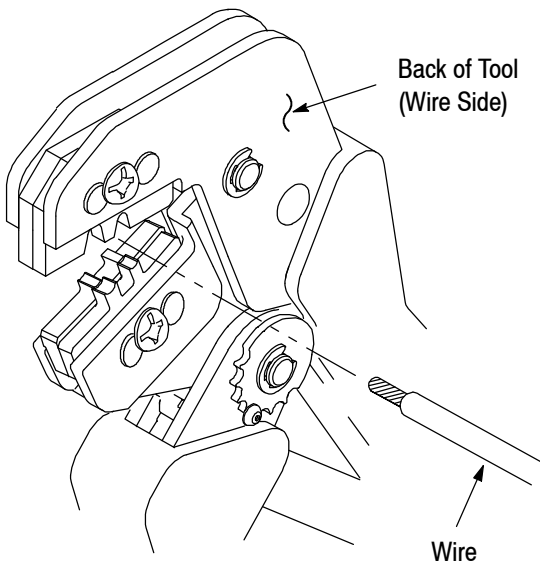
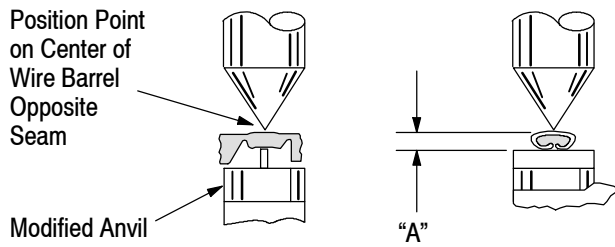

Figure 3



Wire Size AWG (Max)	Crimp Section (Wire Size Marking)	Crimp Height Dimension A and Tolerance (±)
20	22-20	1.230 ± .05 [.0485 ± .0020]
18	18	1.40 ± .05 [.055 ± .0020]

Figure 4

**6. RATCHET (Crimp Height) ADJUSTMENT (Figure 5)**

1. Remove the lock screw from the ratchet adjustment wheel.
2. With a screwdriver, adjust the ratchet wheel from the front side of the tool.
3. Observe the ratchet adjustment wheel. If a tighter crimp is required, rotate the adjustment wheel COUNTERCLOCKWISE to a higher-numbered setting. If a looser crimp is required, rotate the adjustment wheel CLOCKWISE to a lower-numbered setting.
4. Replace the lock screw.

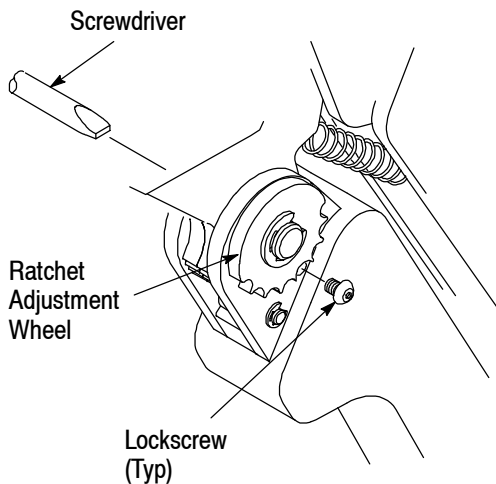

Figure 5

5. Make a sample crimp and measure the crimp height. If the dimension is acceptable, replace and

secure the lock screw. If the dimension is unacceptable, continue to adjust the ratchet, and again measure a sample crimp.

**7. MAINTENANCE**

Ensure that the tool and dies are clean by wiping them with a clean, soft cloth. Remove any debris with a clean, soft brush. Do not use objects that could damage the tool. When not in use, keep handles closed to prevent objects from becoming lodged in the crimping dies, and store in a clean, dry area.

**8. VISUAL INSPECTION**

The crimping dies should be inspected on a regular basis to ensure that they have not become worn or damaged. Inspect the crimp sections for flattened, chipped, worn, or broken areas. If damage or abnormal wear is evident, the tool must be replaced. See Section 9, REPLACEMENT.

**9. REPLACEMENT**

Customer-replaceable parts are shown in Figure 1.

Available separately, PRO-CRIMPER III Hand Crimping Tool Repair Kit 679221-1 includes a replacement nut and a variety of pins, rings, screws, and springs.

If the dies are damaged or worn excessively, they must be replaced.

Order the repair kit and replaceable parts through your Tyco Electronics representative, or call 1-800-526-5142, or send a facsimile of your purchase order to 1-717-986-7605, or write to:

CUSTOMER SERVICE (38-35)  
 TYCO ELECTRONICS  
 PO BOX 3608  
 HARRISBURG PA 17105-3608

**10. REVISION SUMMARY**

Revisions to this instruction sheet include:

- Logo change;
- Changed PRO-CRIMPER II to PRO-CRIMPER III Hand Crimping Tool.