



Chipsmall Limited consists of a professional team with an average of over 10 year of expertise in the distribution of electronic components. Based in Hongkong, we have already established firm and mutual-benefit business relationships with customers from,Europe,America and south Asia,supplying obsolete and hard-to-find components to meet their specific needs.

With the principle of “Quality Parts,Customers Priority,Honest Operation,and Considerate Service”,our business mainly focus on the distribution of electronic components. Line cards we deal with include Microchip,ALPS,ROHM,Xilinx,Pulse,ON,Everlight and Freescale. Main products comprise IC,Modules,Potentiometer,IC Socket,Relay,Connector.Our parts cover such applications as commercial,industrial, and automotives areas.

We are looking forward to setting up business relationship with you and hope to provide you with the best service and solution. Let us make a better world for our industry!



Contact us

Tel: +86-755-8981 8866 Fax: +86-755-8427 6832

Email & Skype: info@chipsmall.com Web: www.chipsmall.com

Address: A1208, Overseas Decoration Building, #122 Zhenhua RD., Futian, Shenzhen, China



Model 5906A
Modular Test Probe Handle with Banana Plug Tip

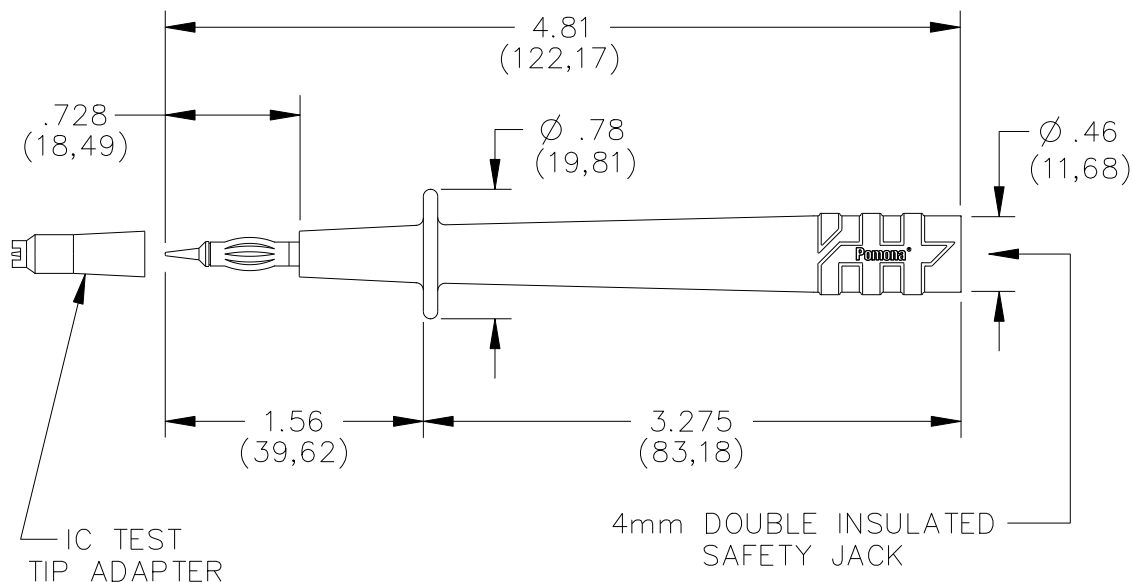

FEATURES

- Model 5906A has been redesigned to meet IEC 61010-031, which is the latest international safety standard for test accessories.
- Probe safety jack mates to Pomona's 5907A, 5908A and 5909A Flexible Test Leads for digital multimeter interfacing.
- Probe tip cap offers easy DIP lead testing and prevents accidental probe shorting.
- 4 mm banana plug probe tip mates into banana jacks for added test flexibility.

MATERIAL

Probe Body: Polypropylene UL94 HB
 Plug Tip: Body – Brass, Nickel Plated
 4mm Safety Jack: Brass, Nickel Plated

RATINGS

Operating Voltage: IEC 61010-031, CAT III 1000 V (with protective cap), CAT II 1000 V (without protective cap).
 Current: 10 Amperes Max.

ORDERING INFORMATION

Model 5906A (Includes a set of one black and one red probe)
 Probe set is also included in many Pomona DMM Test Kits.



USA: Sales: 800-490-2361
 Technical Support: technicalsupport@pomonatest.com
 Fax: 425-446-5844
Europe: 31-(0) 40 2675 150 **International:** 425-446-5500
Where to Buy: www.pomonaelectronics.com

All dimensions are in inches. Tolerances (except noted): .xx = ±.02" (.51 mm), .xxx = ±.005" (.127 mm). All specifications are to the latest revisions. Specifications are subject to change without notice. Registered trademarks are the property of their respective companies.