



Chipsmall Limited consists of a professional team with an average of over 10 year of expertise in the distribution of electronic components. Based in Hongkong, we have already established firm and mutual-benefit business relationships with customers from,Europe,America and south Asia,supplying obsolete and hard-to-find components to meet their specific needs.

With the principle of “Quality Parts,Customers Priority,Honest Operation,and Considerate Service”,our business mainly focus on the distribution of electronic components. Line cards we deal with include Microchip,ALPS,ROHM,Xilinx,Pulse,ON,Everlight and Freescale. Main products comprise IC,Modules,Potentiometer,IC Socket,Relay,Connector.Our parts cover such applications as commercial,industrial, and automotives areas.

We are looking forward to setting up business relationship with you and hope to provide you with the best service and solution. Let us make a better world for our industry!



Contact us

Tel: +86-755-8981 8866 Fax: +86-755-8427 6832

Email & Skype: info@chipsmall.com Web: www.chipsmall.com

Address: A1208, Overseas Decoration Building, #122 Zhenhua RD., Futian, Shenzhen, China



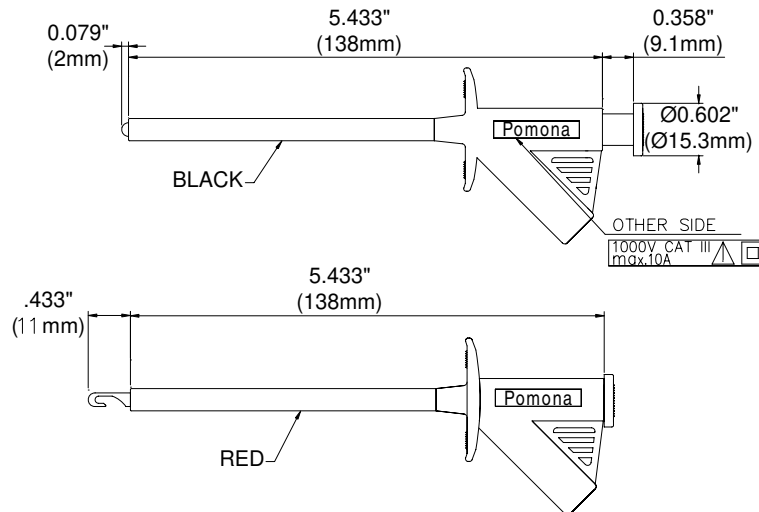

FEATURES:

- Maxigrabber® test clip has been redesigned to meet IEC 1010-2-31. This is the latest international safety standard for test accessories.
- The long shaft is ideal for electronic, electrical and industrial applications where access to hard to reach high voltage test points is a requirement.
- The Tip Guard is Stainless Steel for tip durability..
- Safety sheathed jack mates to Pomona's 5907A, 5908A and 5909A Flexible Test Leads for Digital Multi-Meter interfacing.

MATERIALS:

Hook: Beryllium Copper, Nickel Plated
Plunger, Housing: Polypropylene, Color: One Black, One Red
Banana Jack: Body - Brass, Nickel Plated
Compression Spring: Stainless Steel

RATING:

IEC 1010, Category III, P2 Compliant
Operating Voltage: 1000 VRMS/DC
Operating Current: 10 Amperes Max.

ORDERING INFORMATION: Model 5911B (Includes Set of one black and one red)
The Maxigrabber® Test Clip is also available in various Pomona DMM Test Kits.

All dimensions are in inches. Tolerances (except noted): .xx = ±.02" (.51 mm), .xxx = ± .005" (.127 mm).
All specifications are to the latest revisions. Specifications are subject to change without notice.
Registered trademarks are the property of their respective companies.

Sales: 800-490-2361 Fax: 888-403-3360 Technical Assistance: 800-241-2060
For "Where to Buy" information, visit the Pomona web site at www.pomonaelectronics.com