



Chipsmall Limited consists of a professional team with an average of over 10 year of expertise in the distribution of electronic components. Based in Hongkong, we have already established firm and mutual-benefit business relationships with customers from,Europe,America and south Asia,supplying obsolete and hard-to-find components to meet their specific needs.

With the principle of "Quality Parts,Customers Priority,Honest Operation,and Considerate Service",our business mainly focus on the distribution of electronic components. Line cards we deal with include Microchip,ALPS,ROHM,Xilinx,Pulse,ON,Everlight and Freescale. Main products comprise IC,Modules,Potentiometer,IC Socket,Relay,Connector.Our parts cover such applications as commercial,industrial, and automotives areas.

We are looking forward to setting up business relationship with you and hope to provide you with the best service and solution. Let us make a better world for our industry!



## Contact us

Tel: +86-755-8981 8866 Fax: +86-755-8427 6832

Email & Skype: info@chipsmall.com Web: www.chipsmall.com

Address: A1208, Overseas Decoration Building, #122 Zhenhua RD., Futian, Shenzhen, China



THIS DRAWING IS UNPUBLISHED. RELEASED FOR PUBLICATION  
 © COPYRIGHT - By - ALL RIGHTS RESERVED.

LOC	DIST	REVISIONS			
P	LTR	DESCRIPTION	DATE	DWN	APVD
DF	A0				
	D	ECO-14-013776	10NOV14	MGM	CT

DESCRIPTION	MATERIAL	FINISH
MODULE ASSEMBLY	EPOXY THERMOSET	COLOR: BLACK
GROMMET	FLOURSILICONE 40/50 PER MIL-R-25988	COLOR: NATURAL
CONTACT SOCKET	BERYLLIUM COPPER PER ASTM-B194	GOLD PLATE PER MIL-G-45204
RETAINING CLIP	BERYLLIUM COPPER PER ASTM-B194 OR STAINLESS STEEL PER QQ-S-766	NONE

TOP BUSSING ARRANGEMENT

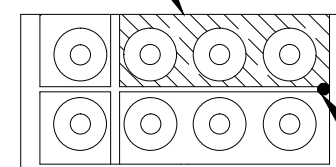

INDEXING INDICATOR

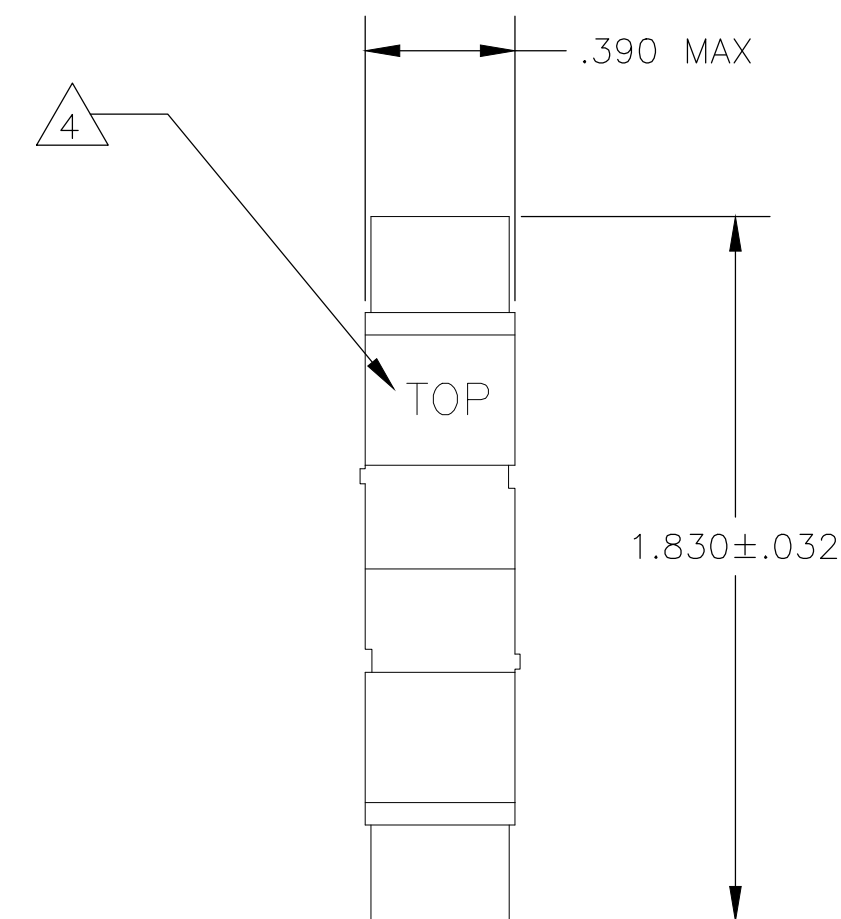
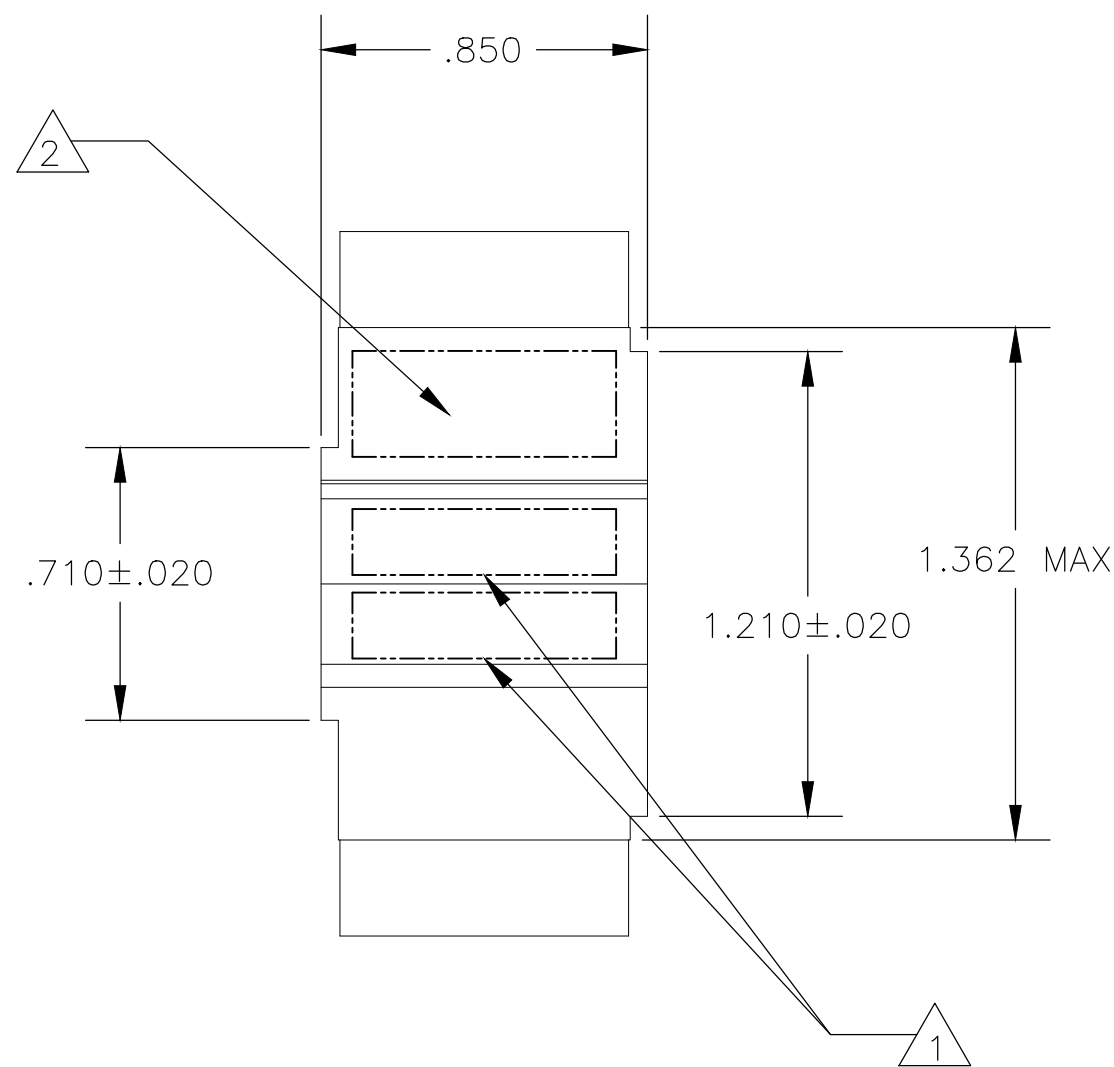

BOTTOM BUSSING ARRANGEMENT

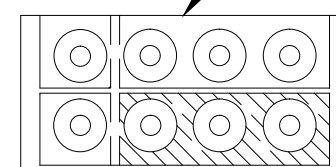

- 1 MARK MODULE ASSEMBLY WITH "AMP", AMP PART NO. AND DATE CODE ON EITHER SIDE.
- 2 MARK MODULE ASSEMBLY WITH CUSTOMER PART NO. 12103B16E15-204 ON EITHER SIDE.
- 3. ROLLS ROYCE QUALITY SPECIFICATION CQC-103 IS INVOKED FOR THIS PART NO.
- 4 MARK WORD "TOP" AT LOCATION SHOWN.

592852

592852-1  
PART NO.

THIS DRAWING IS A CONTROLLED DOCUMENT.		DWN	N. FRITZ	09-21-93	 TE Connectivity
DIMENSIONS: INCHES		CHK	R. RYAN	09-21-93	
TOLERANCES UNLESS OTHERWISE SPECIFIED:		APVD	R. RYAN	09-21-93	
0 PLC ± - 1 PLC ± - 2 PLC ± - 3 PLC ± .005 4 PLC ± - ANGLES ± -		PRODUCT SPEC	NAME		
MATERIAL		APPLICATION SPEC		MODULE, COMBINATION ASSEMBLY SIZE 16 TJ	
FINISH		WEIGHT	A2 00779		RESTRICTED TO
		CUSTOMER DRAWING		SCALE 2:1	SHEET 1 of 1
				REV D	