



Chipsmall Limited consists of a professional team with an average of over 10 year of expertise in the distribution of electronic components. Based in Hongkong, we have already established firm and mutual-benefit business relationships with customers from,Europe,America and south Asia,supplying obsolete and hard-to-find components to meet their specific needs.

With the principle of “Quality Parts,Customers Priority,Honest Operation,and Considerate Service”,our business mainly focus on the distribution of electronic components. Line cards we deal with include Microchip,ALPS,ROHM,Xilinx,Pulse,ON,Everlight and Freescale. Main products comprise IC,Modules,Potentiometer,IC Socket,Relay,Connector.Our parts cover such applications as commercial,industrial, and automotives areas.

We are looking forward to setting up business relationship with you and hope to provide you with the best service and solution. Let us make a better world for our industry!



Contact us

Tel: +86-755-8981 8866 Fax: +86-755-8427 6832

Email & Skype: info@chipsmall.com Web: www.chipsmall.com

Address: A1208, Overseas Decoration Building, #122 Zhenhua RD., Futian, Shenzhen, China



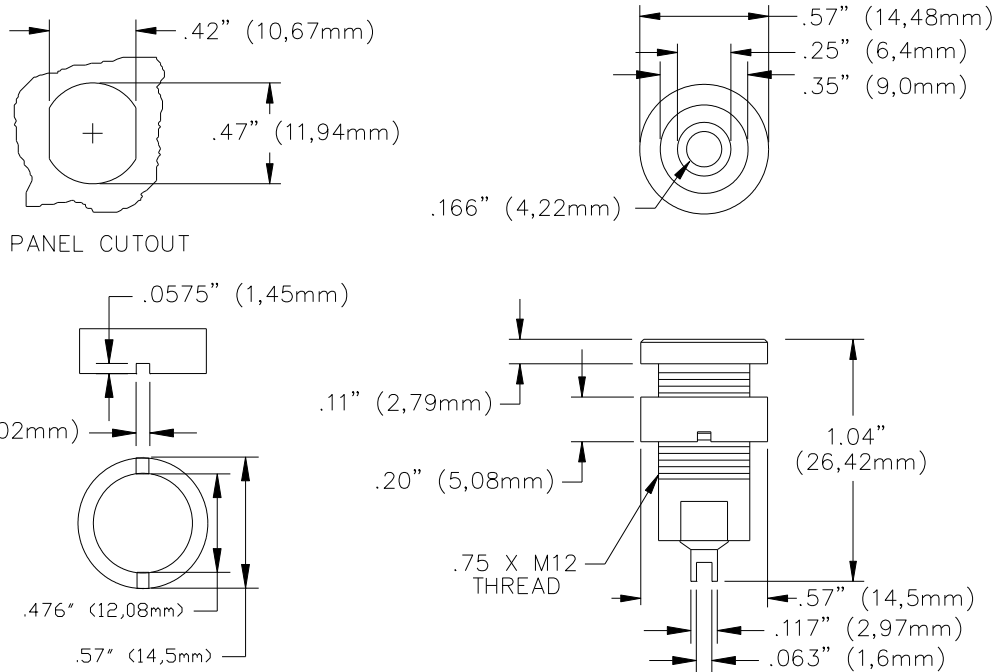

FEATURES:

- ✓ Banana jack mates to Pomona's models 5907A, 5908A & 5909A flexible sheathed style of DMM test leads.
- ✓ Ring threads onto the insulated body to firmly secure jack to panel.
- ✓ Banana jack is gold plated for superb electrical connection.
- ✓ Recommended Panel Thickness: .28" (7,0mm)

MATERIALS:

Banana Jack: Gold Plated Brass
 Insulation: Nylon
 Locking Ring: Nickel Plated Brass

RATING:

Operating Voltage: 1000 V CAT III per IEC61010-031 and IEC61010-1
 Current: 25 Amperes

ORDERING INFORMATION:

Model 5931-Color

Color =: 0 (Black), 2 (Red), 6 (Blue), 9 (White)

Ordering Example: 5931-2 (Red banana jack, Sold in packs of ten)

All dimensions are in inches. Tolerances (except noted): .xx = ±.02" (.51 mm), .xxx = ±.005" (.127 mm).
 All specifications are to the latest revisions. Specifications are subject to change without notice.
 Registered trademarks are the property of their respective companies.

Sales: 800-490-2361 Fax: 888-403-3360 Technical Support: technicalsupport@pomonatest.com
 For "Where to Buy" information, visit the Pomona web site at www.pomonaelectronics.com