



Chipsmall Limited consists of a professional team with an average of over 10 year of expertise in the distribution of electronic components. Based in Hongkong, we have already established firm and mutual-benefit business relationships with customers from,Europe,America and south Asia,supplying obsolete and hard-to-find components to meet their specific needs.

With the principle of “Quality Parts,Customers Priority,Honest Operation,and Considerate Service”,our business mainly focus on the distribution of electronic components. Line cards we deal with include Microchip,ALPS,ROHM,Xilinx,Pulse,ON,Everlight and Freescale. Main products comprise IC,Modules,Potentiometer,IC Socket,Relay,Connector.Our parts cover such applications as commercial,industrial, and automotives areas.

We are looking forward to setting up business relationship with you and hope to provide you with the best service and solution. Let us make a better world for our industry!



Contact us

Tel: +86-755-8981 8866 Fax: +86-755-8427 6832

Email & Skype: info@chipsmall.com Web: www.chipsmall.com

Address: A1208, Overseas Decoration Building, #122 Zhenhua RD., Futian, Shenzhen, China



64 Analog Input RAD Tolerant Telemetry Controller

Description

The LX7730 is a spacecraft telemetry manager IC that functions as a companion to the FPGA. The LX7730 contains a 64 universal inputs multiplexer that can be configured as a mix of differential or single ended sensor inputs. There is a programmable current source that can be directed to any of the 64 universal inputs. The universal inputs can be sampled with a 12-bit analog-to-digital converter at a sample rate up to 13kHz. The universal inputs can also function as variable bi-level inputs with the threshold set by an internal 8 bit digital-to-analog converter. There is an additional 10-bit digital-to-analog current DAC with complementary outputs. Finally, there are 8 fixed threshold bi-level inputs.

The LX7730 is register programmable with 17 addressable 8-bit registers. Two options are available for communication with the host FPGA. First there is an 8-bit parallel bus with 5 address bits and a read/write bit that can communicate at a speed of up to 25MHz. The second option is a pair of 12.5Mbps SPI interfaces that can support redundant (alternating not simultaneous) communication to two different hosts.

The LX7730 offers 1 kV ESD pin protection on FPGA interface pins and 500V ESD protection to all CH# and BLI# pins. The dielectric isolated process is failsafe. The LX7730 has enable registers that allow most of the device to be shut down to reduce power consumption and supports cold sparing on its signal pins.

The controller is designed for use in rugged environments. It is packaged in a 132 pins ceramic quad flat pack and operates over a -55°C to 125°C temperature range. It is radiation tolerant to 100krad TID and 50krad ELDRs as well as single event effects.

Features

- 64 channel MUX
- Break-before-make switching
- 13kSPS 12-bit ADC
- 3% Precision Adjustable Current Source
- 1% Precision 5.00V Source
- Threshold Monitoring
- 8 x Bi-level Logic
- 10-bit DAC
- Parallel or Dual SPI Interface
- Radiation Tolerant: 100krad TID, 50kad ELDRS

Applications

- Spacecraft Health Monitoring
- Attitude Control
- Payload Equipment

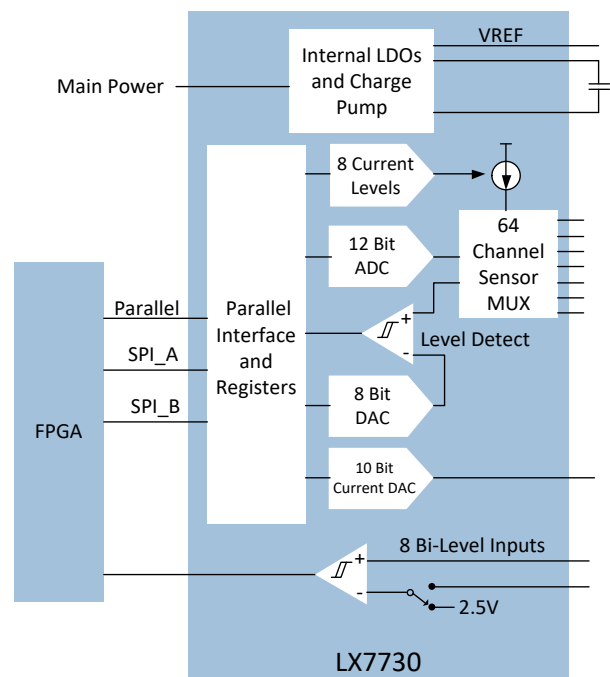

Figure 1 · Product Highlight

Pin Configuration and Pinout

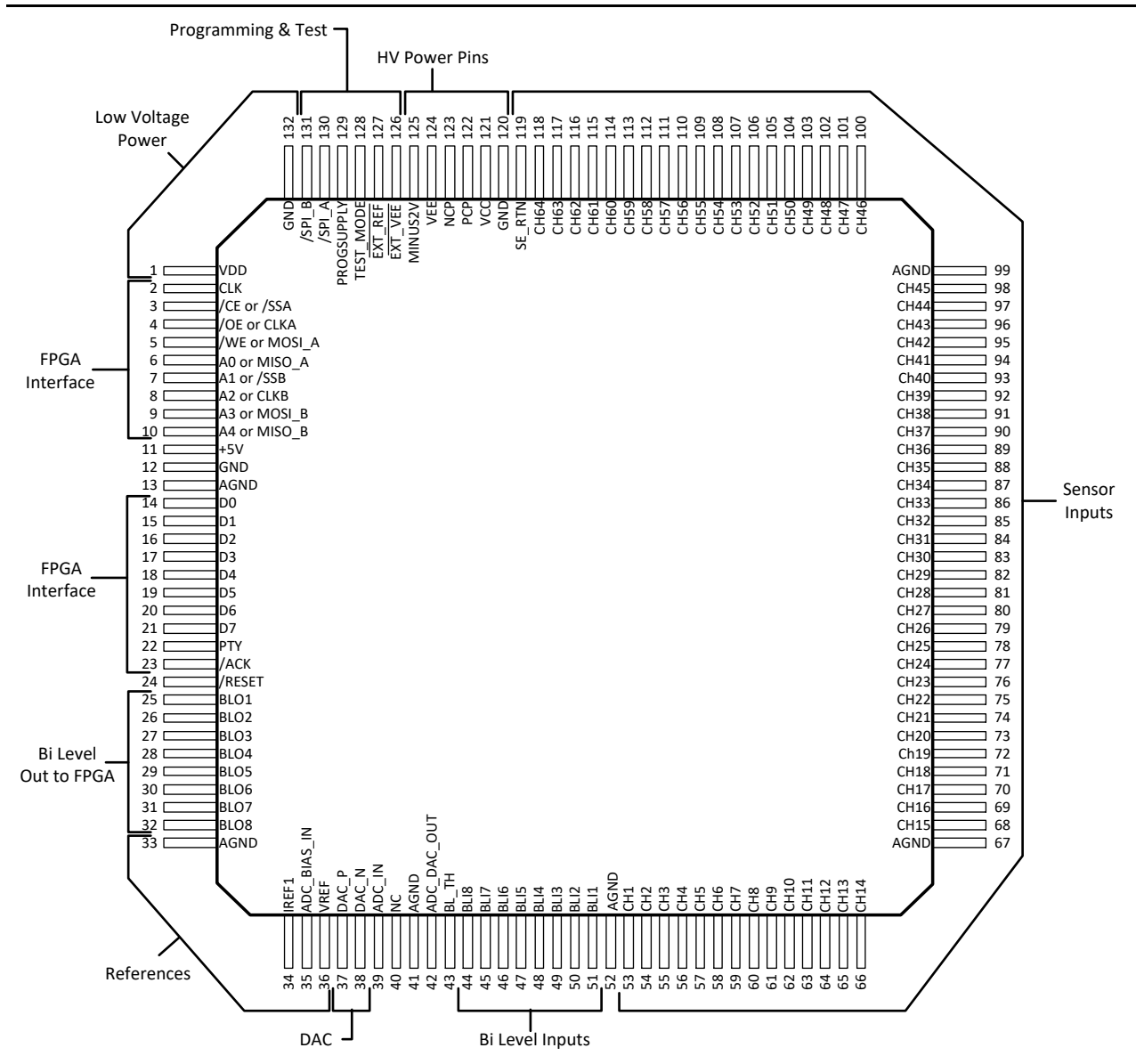

Figure 2 · Pinout

Ordering Information

Operating Temperature	Type	Package	Part Number	Flow	Packaging Type
-55°C to 125°C	Hermetic	CQFP 132L	LX7730MFQ-V SMD5962-1721901VXC	QML-V	Tray
			LX7730MFQ-Q SMD5962-1721901QXC	QML-Q	
			LX7730MFQ-ES	Engineering Samples	

Pin Description

Pin Number	Pin Designator	Description
1	VDD	VDD - Power reference pin – This pin is used to reference the output logic level to the FPGA. It connects to the FPGA I/O power supply.
2	CLK	System Clock – Logic Input – This clock input is used to time synchronous logic needed to perform the ADC conversions. There is a weak pull-down on this pin.
3	/CE or /SSA	Chip enable or Slave Select channel A – Logic Input – Provides chip enable for the parallel interface when /SPI_A and /SPI_B are high. Provides slave select for the SPI channel A interface when the /SPI_A pin is pulled low. In both cases the logic is active low. There is a weak pull-up on this pin.
4	/OE or CLKA	Output enable or SPI Clock channel A – Logic Input – Provides output enable (read enable) for the parallel interface when /SPI_A and /SPI_B are high. Provides the clock for the SPI channel A interface when the /SPI_A pin is pulled low. There is a weak pull-up on this pin.
5	/WE or MOSI_A	Write enable or SPI MOSI channel A – Logic Input – Provides active low write enable for the parallel interface when /SPI_A and /SPI_B are high. Provides data input for the SPI channel A interface when the /SPI_A pin is pulled low. There is a weak pull-up on this pin.
6	A0 or MISO_A	Address bit 0 or SPI MISO channel A – Logic I/O – Provides the address bit 0 (LSB) for the parallel interface when /SPI_A and /SPI_B are high. Provides data output for the SPI channel A interface when the /SPI_A pin is pulled low. There is a weak pull-down on this pin.
7	A1 or/SSB	Address bit 1 or Slave Select channel B – Logic Input – Provides the address bit 1 for the parallel interface when /SPI_A and /SPI_B are high. Provides slave select for the SPI channel B interface when the /SPI_B pin is pulled low. There is a weak pull-up on this pin.
8	A2 or CLKB	Address bit 2 or SPI Clock channel B – Logic Input – Provides the address bit 2 for the parallel interface when /SPI_A and /SPI_B are high. Provides the clock for the SPI channel B interface when the /SPI_B pin is pulled low. There is a weak pull-down on this pin.
9	A3 or MOSI_B	Address bit 3 or SPI MOSI channel B – Logic I/O – Provides the address bit 3 for the parallel interface when /SPI_A and /SPI_B are high. Provides data input for the SPI channel B interface when the /SPI_B pin is pulled low. There is a weak pull-down on this pin.
10	A4 or MISO_B	Address bit 4 or SPI MISO channel B – Logic I/O – Provides the address bit 4 (MSB) for the parallel interface when /SPI_A and /SPI_B are high. Provides data output for the SPI channel B interface when the /SPI_B pin is pulled low. There is a weak pull-down on this pin.
11	+5V	+5V power rail – Power Pin – This pin is the low voltage power rail. It is generated internally using a linear regulator connected to the VCC rail. A bypass capacitor to GND is required.
12, 120, 132	GND	Ground – Power and Signal pin – These pins provide a return path for power supplies and a reference point for signals.
13, 33, 41, 52, 67, 99	AGND	Analog Ground –Signal pin – These pins provides a reference point for signals.

Pin Number	Pin Designator	Description
14-21	D#	Data I/O for the parallel interface – Logic I/O - Provides the data bits, D0 (LSB) (pin 14) through D7 (pin 21) for the parallel interface. There is a weak pull-down on these pins.
22	PTY	Parity I/O Bit – Logic I/O – Provides the parity bit for the parallel data communication. Even parity is used for the combination of address and data bits and is used in both directions. There is a weak pull-down on this pin.
23	/ACK	Acknowledge Bit – Logic Output – In the event of a parity error encountered in a serial or parallel data transfer, the /ACK pin is de-asserted (pulled high). see “FPGA Interface” for conditions.
24	/RESET	System Reset – Logic Input– This pin provides a forced reset to the default state of all registers and flip-flops within the LX7730. The logic is active low which requires the pin to be pulled low to assert a reset.
25-32	BLO#	Fixed Threshold Bi Level detector output to FPGA – Logic Output– Provides the state of the Fixed Level Bi Level Input of the same # directly to the FPGA.
34	IREF1	Reference current programming pin –Signal Input – This pin is used to create a precision reference current for the IC. A 20k Ω 1% resistor should be attached from this pin to AGND. IREF2 is an internal redundant resistor and can be selected should IREF1 fail.
35	ADC_BIAS_IN	ADC Reference current programming pin –Signal Input – This pin is used to create a precision reference current for the ADC. A 7.87k Ω , 0.1% resistor should be attached from this pin to AGND.
36	VREF	+5V reference – Signal Output – This pin is a precision reference voltage that can be used to provide a voltage reference to sensors for precision measurements. A bypass capacitor to AGND is required. The internal reference can be disabled and an external reference connected to this pin; the internal voltage reference must be disabled in this case using the /EXT_REF programming pin.
37,38	DAC_#	10-Bit Current DAC output – Signal Pin – This pin provides the output for the 10-Bit current DAC; it should be terminated in a resistor of 1.5k Ω or less to AGND. The DAC_P output increases with the LSB level and the DAC_N output decrease with the LSB level. DAC_P maximum occurs at full scale setting and DAC_N output maximum occurs at zero setting. If the “Use DAC” bit is asserted; this implies the DAC is used to control the current setting of the Current De-Mux. In this case the DAC_P should be left open circuited and the DAC_N terminated to GND.
39	ADC_IN	Analog to Digital Converter Input – Signal Pin – This pin is used to monitor the output of the anti-aliasing filters or to provide an input signal directly into the ADC from an external source. When used as an input, the anti-aliasing filter can be put in a Hi-Z output state.
40	NC	No Connect – Test Pin – This pin is used for testing and should be left floating in the application.
42	ADC_DAC_OUT	ADC gain scale current programming pin –Signal Input – This pin is used to create a precision load for the current DAC portion of the SAR ADC. A 158 Ω 0.1% resistor should be attached from this pin to AGND.
43	BL_TH	External Bi-Level Threshold Setting – Signal Pin – This pin is used to

Pin Number	Pin Designator	Description
		override the internal 2.5V bi-Level threshold setting and change it to the voltage applied to this pin. An addressable register bit is used to select either the internal or external bi-level threshold. Connect it to ground when not used.
44-51	BLI#	Fixed threshold Bi Level Signal Input – Signal Input Pin – This pin is fixed threshold bi-level input: channel 8 (pin 44) decreasing to channel 1 (pin 51).
53-118	CH#	General purpose sensor interface – Signal I/O - This pin provides input for the sensor interface or output for the adjustable current source. Channel 1 (pin 53) to channel 64 (pin 118). A few AGND pins are interspersed.
119	SE_RTN	Single Ended Sensor Return – Signal Pin – This pin is used as a common return for single ended sensor inputs.
121	VCC	Main power supply – Power Input – This pin is the main power supply. The internal (VEE and +5V) voltage regulators are powered from this rail.
122	PCP	Charge Pump Transfer Capacitor Positive Terminal – Power Pin – This pin is used for the charge pump used to generate VEE; it swings between GND and VCC. Connect a 0.47 μ F capacitor between this pin and the NCP pin.
123	NCP	Charge Pump Transfer Capacitor Negative Terminal – Power Pin – This pin is used for the charge pump used to generate VEE; it swings between GND and VEE. Connect a 0.47 μ F capacitor between this pin and the PCP pin.
124	VEE	Negative power rail – Power I/O – This pin is the negative voltage power rail. It can be generated internally (using the charge pump) or supplied from an external source connected to this pin. Use a bypass capacitor to GND. The charge pump can be disabled by shorting the /EXT_VEE pin to GND.
125	MINUS2V	-2V Intermediate power rail – Power Pin – This pin is the low negative voltage power rail. It is generated internally using a linear regulator connected to the VEE rail. A bypass capacitor to GND is required.
126	/EXT_VEE	Enable external VEE – Programming pin – This pin disables the VEE charge pump if it is shorted to ground. If high, the VEE charge pump is enabled. There is a weak pull-up on this pin.
127	/EXT_REF	Enable External Reference – Programming pin – This pin disables the internal voltage reference when it is shorted to ground. If high, the internally generated voltage reference is used. There is a weak pull-up on this pin.
128	TEST_MODE	Test and Trim Pins – Programming Pins - This pin is used for in package trim and testing of the device. In normal use it should be connected to GND.
129	PROGSUPPLY	Trim Power Supply – Power Pin – This pin is used to blow fusible links when trimming the part in package at the factory. In normal application this pin should be shorted to +5V.
130	/SPI_A	Enable SPI Interface A – Logic Input – This pin is active low. Asserting this pin enables the SPI channel A interface and deactivates the parallel interface and SPI channel B. If both /SPI_A and /SPI_B pins are low, the first asserted pin dominates. There is a weak pull-up on this pin.
131	/SPI_B	Enable SPI Interface B – Logic Input – This pin is active low. Asserting this pin enables the SPI channel B interface and deactivates the parallel interface and SPI channel A. If both /SPI_A and /SPI_B pins are low, the first asserted pin dominates. There is a weak pull-up on this pin.

Functional Block Diagram

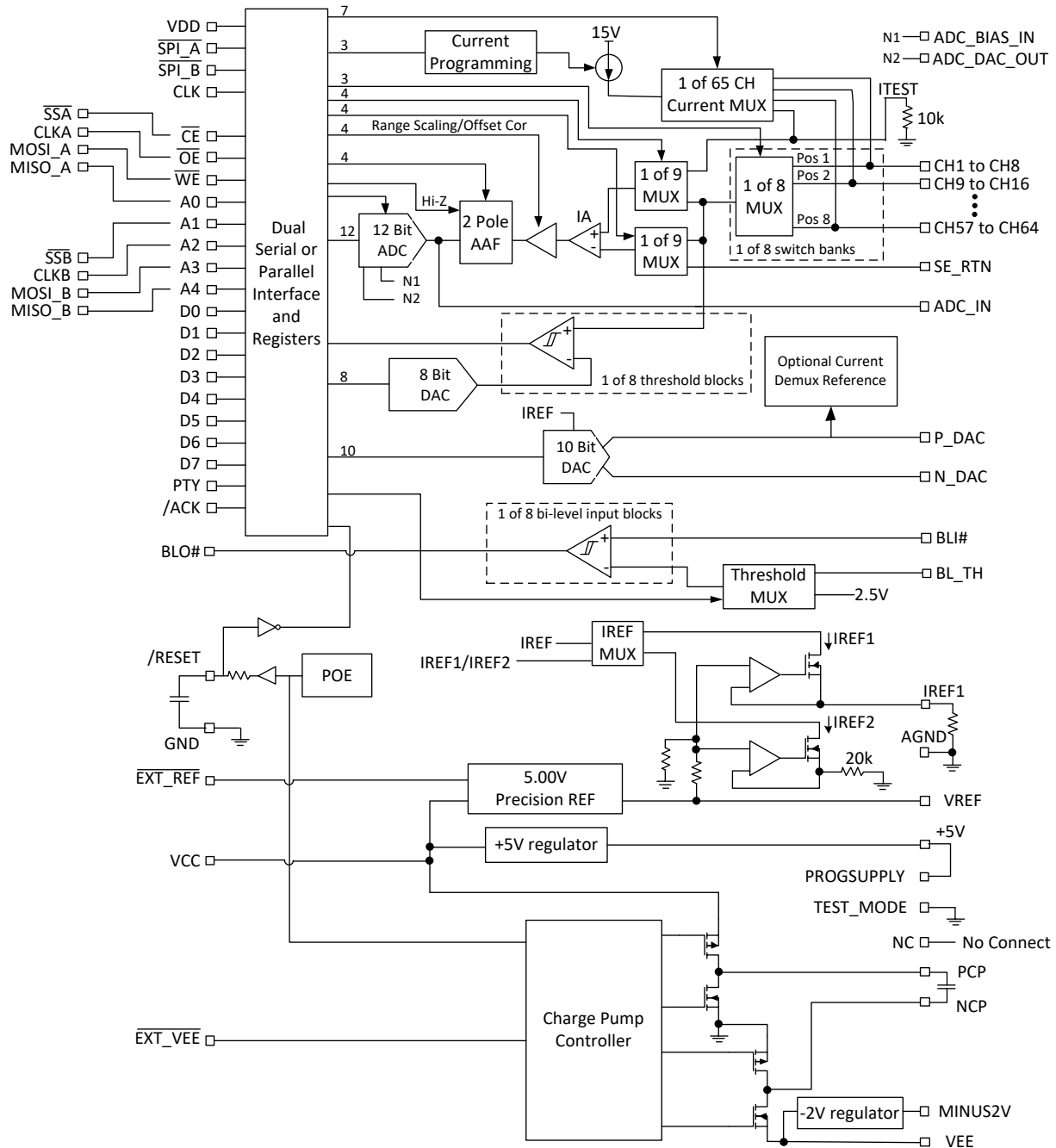

Figure 3 · LX7730 Top Level Block Diagram

Functional Block Diagram

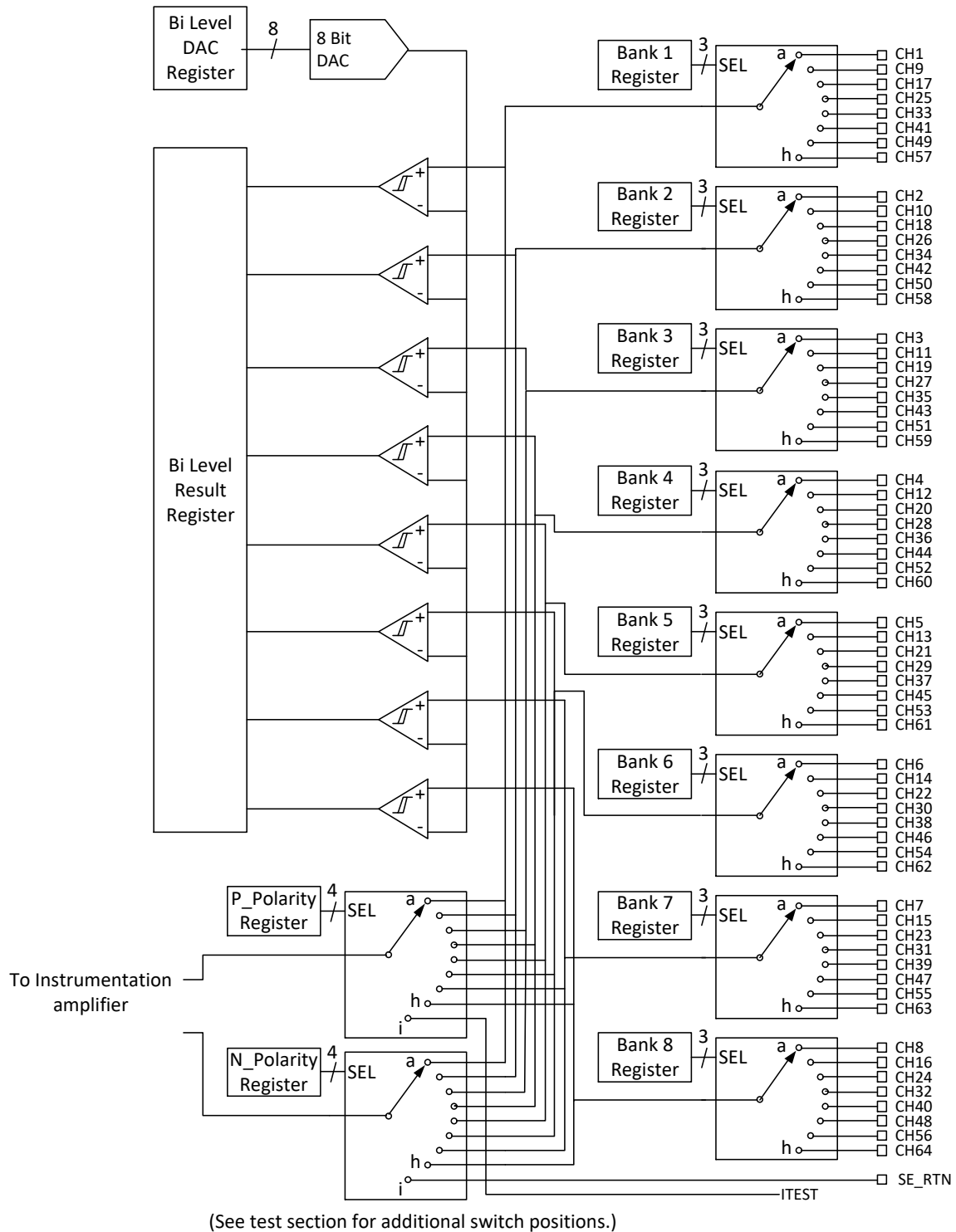

Figure 4 · LX7730 Sensor Multiplexer Expanded View Block Diagram

Absolute Maximum Ratings

Note: Stresses above those listed in “ABSOLUTE MAXIMUM RATINGS”, may cause permanent damage to the device. This is a stress only rating and operation of the device at these or any other conditions above those indicated in the operational sections of this specification is not implied.

Parameter	Min	Max	Units
Main Power (VCC) to GND	-0.5	20	V
Logic Supply Voltage (VDD) to GND	-0.5	7	V
+5V (current internally limited)	-0.5	7	V
VEE (current internally limited)	-20	+0.5	V
FPGA interface (Pins 2 thru 32) to GND	-0.5	7	V
Sensor Inputs (CH1 - CH64, SE_RTN) to GND	-15	15	V
Bi-Level Inputs (BLI1 to 8) to GND	-10	10	V
Input clamp currents		3	mA
ADC_IN, AI_OUT, DAC_N/P, RESET, VREF, BL_TH, IREF# to GND	-0.5	7	V
Operating Junction Temperature	-55	150	°C
Storage Junction Temperature	-65	160	°C
ESD Susceptibility (HBM, ML_STD883, Method 3015.7) Except as noted: Low voltage I/O and power pins are rated to 1000V.		500	V
Peak Lead Solder Temperature (10 seconds)		260 (+0, -5)	°C

Operating Ratings

Note: Performance is generally guaranteed over this range as further detailed below under Electrical Characteristics.

Parameter	Min	Max	Units
VCC	11.4	16	V
VDD	2.25	5.5	V
VEE (when externally applied)	-16	-10	V
+5V (current internally limited)	4.5	5.5	V
FPGA Interface (Pins 2 thru 32) to GND		5.5	V
Sensor Inputs (CH1 - CH64, SE_RTN) to GND		10	V
Bi-Level Inputs (BLI1 to 8) to GND		8	V
Input Clamp Currents		Fault condition ≤ 3	mA
ADC_IN, AI_OUT, DAC_N/P, RESET, VREF, BL_TH, IREF# to GND		5.5	V
Current from Reference Voltage (VREF pin)	0	10	mA

Thermal Properties

Thermal Resistance	Typ	Units
θ_{JC}	2	°C/W

Note: The θ_{JC} numbers assume no forced airflow. Junction Temperature is calculated using $T_J = T_C + (PD \times \theta_{JC})$. In particular, θ_{JC} is a function of the PCB construction. The stated number above is for a four-layer board in accordance with JESD-51 (JEDEC).

Electrical Characteristics

The following specifications apply over the operating ambient temperature of $-55^{\circ}\text{C} \leq T_A \leq 125^{\circ}\text{C}$ except where otherwise noted with the following test conditions: $V_{CC} = 15\text{V}$, $V_{DD} = 3.3\text{V}$; $R_{IREF} = 20\text{k}\Omega$ 1%; $R_{ADC_BIAS_IN} = 7.87\text{k}\Omega$ 0.1%; $R_{ADC_DAC_OUT} = 158\Omega$ 0.1%; / EXT_VEE open, /EXT_REF open. CH1 and CH2 selected and CH2 grounded. CLK = 500kHz. Reg 7 = 001010xx. Typical parameter refers to $T_J = 25^{\circ}\text{C}$. Positive currents flow into the pin.

Symbol	Parameters	Test Conditions/Comments	Min	Typ	Max	Units
Operating Current						
I_{VCC}	VCC Normal Current		38	70	85	mA
I_{VCC}	VCC Standby Current	Chip Enable Register de-asserted	2.0	4.0	7.0	mA
I_{VEE}	VEE Current	Using external VEE source. Positive current out of pin.	-2	-4.7	-7.0	mA
I_{VDD}	VDD Current	All digital I/O pins static		0.9		mA
Under Voltage Detection						
V_{VCC}	VCC UVLO	Voltage rising; 200mV Hysteresis	9.5	10	10.5	V
V_{VEE}	VEE UVLO	Voltage falling; 200mV Hysteresis	-8.2	-8.0	-7.5	V
V_{+5V}	+5V UVLO	Voltage rising; 200mV Hysteresis	3.9	4.15	4.4	V
Internally Regulated Voltages and Currents						
V_{VEE}	VEE voltage	$V_{CC} - V_{VEE} $	1.5	2.6	3	V
V_{+5V_NOM}	+5V voltage		4.75	5.00	5.25	V
V_{REF_NOM}	VREF voltage		4.95	5.00	5.05	V
V_{IREF}	IREF pin voltage	$R_{IREF} = 20\text{k}\Omega$	1.568	1.600	1.632	V
Analog MUX						
$V_{CH\#_DIFF}$	Differential Range	CH# to CH# or CH# to SE_RTN	0		5	V
$V_{CH\#_COMM}$	Common Mode Range	With $V_{CH1} - V_{CH2} = 5\text{V}$	-5		5	V
$V_{CH\#_CLP_P}$	Voltage Clamp (power applied)	Clamp Current = 1mA (into pin) ⁽¹⁾	VCC	16	17	V
		Clamp Current = 1mA (out of pin)	-23	-20	-16	
$V_{CH\#_CLP}$	Voltage Clamp ($V_{CC}=V_{VEE}=0$)	Clamp Current = 1mA (into pin)	16	20	23	V
		Clamp Current = 1mA (out of pin)	-23	-20	-16	
All to V_{CH1}	Ch – Ch Isolation	CH1 and SE_RTN selected; CH2 to CH64 each with series 2k Ω to a 10kHz common source, CH1 with 2k Ω to GND. SE_RTN to GND.		60		dB
V_{ADC_IN}	Settling Time	Including dead time			10	μs
$I_{CH\#_BIAS}$	Bias Current	$V_{CH1} = -5\text{V}$ to 5V	-200	0	200	nA
$I_{CH\#_LEAK}$	Leakage Current	$V_{CH1} = -5\text{V}$ to 5V ; IC powered off	-200	0	200	nA

Symbol	Parameters	Test Conditions/Comments	Min	Typ	Max	Units
I _{SE_RTN}	Bias Current	V _{SE_RTN} = -5V to 5V	-200	0	200	nA
I _{SE_RTN}	Leakage Current	V _{SE_RTN} = -5V to 5V; IC powered off	-200	0	200	nA
Programmable Current Source						
I _{CH#_FSC}	Full scale current	Use_DAC off; Doub_Wt off	1880	1940	2000	μA
I _{CH#_IN}	Integral nonlinearity	Use_DAC off; Doub_Wt off	-7.5	0	7.5	
I _{CH#_DN}	Differential nonlinearity	Use_DAC off; Doub_Wt off	-7.5	0	7.5	
I _{CH#_FSC_DW}	Full scale current	Use_DAC off; Doub_Wt on	3710	3830	3950	
I _{CH#_IN_DW}	Integral nonlinearity	Use_DAC off; Doub_Wt on	-15	0	15	
I _{CH#_DN_DW}	Differential nonlinearity	Use_DAC off; Doub_Wt on	-15	0	15	
I _{CH#_DAC31}	At DAC = code 31	Use_DAC asserted	290	300	310	
I _{CH#_IN_DAC}	Integral nonlinearity	Use_DAC asserted; straight line from 0 to code 31.	-2	0	2	
I _{CH#_DN_DAC}	Differential nonlinearity	Use_DAC asserted; first 31 codes.	-2	0	2	
Instrumentation Amplifier with gain control (measured at ADC_IN)						
V _{IA_OFFSET}	Calculated by interpolation	Gain = 0.4; Referenced to Input -55°C , 25°C	-2	13	25	mV
		Gain = 0.4; Referenced to Input 125°C	-2	13	30	
		Gain = 2.0; Referenced to Input -55°C , 25°C	-3	0	3	
		Gain = 2.0; Referenced to Input 125°C	-3	0	4	
		Gain = 10; Referenced to Input -55°C , 25°C	-3	0	3	
		Gain = 10; Referenced to Input 125°C	-3	0	3	
V _{IA_GAIN}	Gain = (Vo2 – Vo1)/(Vi2 - Vi1)	Gain = 0.4	0.398	0.400	0.402	Vout/Vin
		Gain = 2.0	1.992	1.998	2.004	
		Gain = 10	9.965	9.995	10.025	
T _{IA_RISE}	Output Step Rise Time Reg 7 =001010xx 10% to 90%; Vo =2Vpp	Gain = 0.4	120	210	333	us
		Gain = 2.0	31	52	105	
		Gain = 10	31	52	105	
P _{1_IA}	Pole frequency	Set Reg 7 for 400Hz	360	600	1000	Hz
P _{2_IA}	Pole frequency	Set Reg 7 for 2kHz	1.4	2.8	3.8	kHz
P _{3_IA}	Pole frequency	Set for 10kHz	8.8	13.5	18.2	kHz
Analog-to-Digital Converter (input at ADC_IN)						
V _{ADC_LR}	Linear Range	Input applied to ADC_IN	0		2.0	V
V _{ADC_FSE}	Full scale error	Best fit curve applied to full range	-2.5	0	2.5	%
V _{ADC_OFFSET}	Offset Error		-10	0	10	mV
V _{ADC_IN}	Integral nonlinearity	-55°C , 25°C	-6	0	6	LSB
		125°C	-7	0	7	

Symbol	Parameters	Test Conditions/Comments	Min	Typ	Max	Units
V _{ADC_DN}	Differential nonlinearity		-1	0	3	
I _{ADC_LEAK}	Leakage current	IA in Hi-Z state; ADC not converting	-0.2	0	0.2	μA
t _{CONV}	Conversion Time	Cycles of CLK pin, guaranteed by design		13		clocks
t _{ACQU}	Acquisition Time			25		
t _{SAMP}	Sample Period			38		
Adjustable threshold Bi-Level MUX and DAC						
V _{DAC8_MAX}	Threshold DAC Max Output	Using code value of 255/255	4.95	5.00	5.05	V
V _{DAC8_LSB}	Threshold DAC LSB Weight			19.5		mV
V _{DAC8_IL}	DAC Integral Linearity	Using codes 20 to 240, best fit straight line	-1		1	LSB
V _{DAC8_OFF}	Offset error		-10		10	mV
V _{DAC8_DL}	DAC Differential Linearity		-0.75		0.75	LSB
V _{CMP#_HYS}	Hysteresis	Rising threshold = DAC output; falling threshold has hysteresis	75	112	150	mV
10 Bit Current DAC						
I _{DAC10_PFS}	Full scale		-2.06	-2.00	-1.94	mA
I _{DAC10_NFS}	Full scale			0		mA
I _{DAC10_LSB}	LSB Weight			-1.953		μA
I _{DAC10_IN}	Integral Nonlinearity		-5	0	5	LSB
I _{DAC_DN}	Differential Nonlinearity		-0.5	0	0.5	LSB
V _{DAC10_PN}	Compliance Range		0		3	V
T _{DAC10_SET}	Settling			0.2	1	μs
Fixed Threshold Bi-Level Inputs						
V _{BLI#_THRES}	Threshold (Rising Voltage)	Internal reference	2.45	2.50	2.55	V
		With external 2.50V reference	2.45	2.50	2.55	
V _{BLI#_HYS}	Hysteresis	Only falling threshold has hysteresis; Rising is dead on	60	120	180	mV
V _{BLI#_CLP_P}	Voltage Clamp (power applied)	Clamp Current = 1mA (into pin)	15	20	23	V
		Clamp Current = 1mA (out of pin)	-23	-20	-15	
V _{BLI#_CLP}	Voltage Clamp (power removed)	Clamp Current = 1mA (into pin)	15	20	23	V
		Clamp Current = 1mA (out of pin)	-23	-20	-15	
I _{BLI#_BIAS}	Bias Current	V _{BLI1} = 0V to 5V	-0.2	0	1.5	μA
I _{BLI#_LEAK}	Leakage Current	V _{BLI1} = 0V to 5V; IC powered off	-0.2	0	1.5	μA
t _{BLI#}	Propagation Delay	High to low transition	0.3	0.8	1.3	μs
		Low to high transition	0.8	2.1	3.4	
V _{BL_TH}	Ext Threshold Pin Range		0.1		4.9	V
I _{BL_TH}	Threshold Pin Leakage	V _{BL_TH} = 0V to 5V	-0.2	0	2.0	μA

Logic Levels for FPGA Interface I/Os						
V _{LOG_IN}	Input Logic Threshold	Threshold Voltage	35	50	65	%VDD
V _{EXT_VEE} , V _{EXT_VREF}	Program pins	Threshold Voltage	2.0	2.5	3.0	V
V _{LOG_OUT}	Logic Output Levels	High Logic Level (4mA source)	VDD-0.3		VDD	V
		Low Logic Level (4mA sink)	0		0.3	
I _{LOG_IN}	Input currents	/SPI_A, /SPI_B: VLOG_IN = 3.3V	-2	0	2	μA
		/SPI_A, /SPI_B: VLOG_IN = 0V	-10	-4	-1.5	
		Pins 2,6,8-10,14-21, 22: I/O as input VLOG_IN = 3.3V	1.5	4	10	
		Pins 2,6,8-10,14-21, 22: I/O as input VLOG_IN = 0V	-2	0	2	
		Pins 3-5,7: I/O as input VLOG_IN = 3.3V	-2	0	2	
		Pins 3-5,7: I/O as input VLOG_IN = 0V	-10	-4	-1.5	
		/EXT_VREF or /EXT_VEE = 5V	-2	0	2	
		/EXT_VREF or /EXT_VEE = 0V	-12	-6	-1.5	
		/RESET with power on enabled: VLOG_IN = 3.3V	1.5	4	10	
		/RESET with power on enabled: VLOG_IN = 0V	-150	-66	-33	

(1) Voltage Clamp (power applied) 1mA into pin will clamp to the VCC supply

Register Map

Note: Each register has an address which is selectable using the address bits. All registers can be read by asserting the OE line. All registers can be written to (with the exception of the ADC High and Low Bytes) by asserting the WE line.

Addr	Type	Name	Bit 7	Bit 6	Bit 5	Bit 4	Bit 3	Bit 2	Bit 1	Bit 0	
0	W	Master reset	0	1	1	0	1	0	1	0	
1	R/W	Function enable	Chip Enable	Sensor MUX	Current Source Disable	Bi-Lvl Comp	Analog Amp	10 Bit DAC	Fixed Bi-Lvl	12 bit ADC	
2	R/W	Power status	Use IREF2	Mon VCC	Mon VEE	Mon +5V	Mon VREF	VCC UVLO	VEE UVLO	+5V UVLO	
3	R/W	Non-Inv MUX Channel	Not Used			Non-inverting Input MUX Channel Selection					
4	R/W	Inverting MUX Channel	-	Use SE_RTN	Inverting Input MUX Channel Selection (Overridden if SE_RTN bit set)						
5	R/W	Current MUX Level	Use DAC	Not Used			Double Weight	Current Setting (1 to 8)			
6	R/W	Current MUX Channel	Not Used			Current Channel Selection (1 to 64)					
7	R/W	Signal Conditioning Amp	-	AAF Off	2 nd Pole Freq.		1st Pole Freq.		Gain Setting		
8	R/W	ADC Control	Auto Sample Rate			Auto Conv	Data Ready	Busy	Start Conv	ADC_IN = HiZ	
9	RO	ADC Upper Byte	Upper Byte for the 12 bit ADC								
10	RO	ADC Lower Bits	Not Used				Lower Bits for the 12 bit ADC				
11	R/W	BL Threshold DAC	Threshold DAC setting								
12	R/W	Bi-Level Bank Switch Position	Use BL_TH	Not Used			EN BL Sw Pos	1 of 8 switch positions			
13	RO	Bi-Level Status	Comp 7	Comp 6	Comp 5	Comp 4	Comp 3	Comp 2	Comp 1	Comp 0	
14	R/W	DAC Upper Byte	Upper byte for 10 bit DAC output								
15	R/W	DAC Lower Bits	Not Used						Lower bits		
16	R/W	Calibration	IA Short	Not Used		Cont Check	NP TEST	Not Used	I GND	-	
17	R/W	OTP	Not Used						OTP_out_select	OTP_in_select	

There are 32 addressable registers. Some will be reserved for self-test. For details about each register see Theory of Operation Section below.

Trimming / Test Register

Addr	Bit 7	Bit 6	Bit 5	Bit 4	Bit 3	Bit 2	Bit 1	Bit 0
18	cmux 2	cmux 1	cmux 0	vref 4	vref 3	vref 2	vref 1	vref 0
19	vbgtc 3	vbgtc 2	vbgtc 1	vbgtc 0	offs 3	offs 2	offs 1	offs 0
20	vbg 4	vbg 3	vbg 2	vbg 1	vbg 0	vtoi 4	vtoi 3	vtoi 2
21	vtoi 1	vtoi 0	osc 3	osc 2	osc 1	osc 0	ADCvtoi 4	ADCvtoi 3
22	ADCvtoi 2	ADCvtoi 1	ADCvtoi 0					
23	lo_dis							

Trimming

One time trimming circuits will set the default for all trimming bits. Using the OTP_in_select bit the defaults can be read by the SPI or parallel bus. Writing to the trimming registers along with the OTP_out_select bit allows the defaults to be modified; when OTP_out_select is de-asserted, the trim values revert back to the default state.

Name	Bits	Description
cmux	3	Adjust 10bit I DAC reference
vref	5	Vref adjust
vbgtc	4	Bandgap temperature coefficient adjust
offs	4	Instrumentation amplifier offset adjust
vbg	5	Bandgap value adjust
vtoi	5	Programmable current source adjust (global vtoi adjust, trimmed first)
osc	4	Charge pump clock adjust
ADCvtoi	5	ADC current reference adjust
lo_dis	1	Disables the output of all i/o pins for the input threshold test

Typical Application

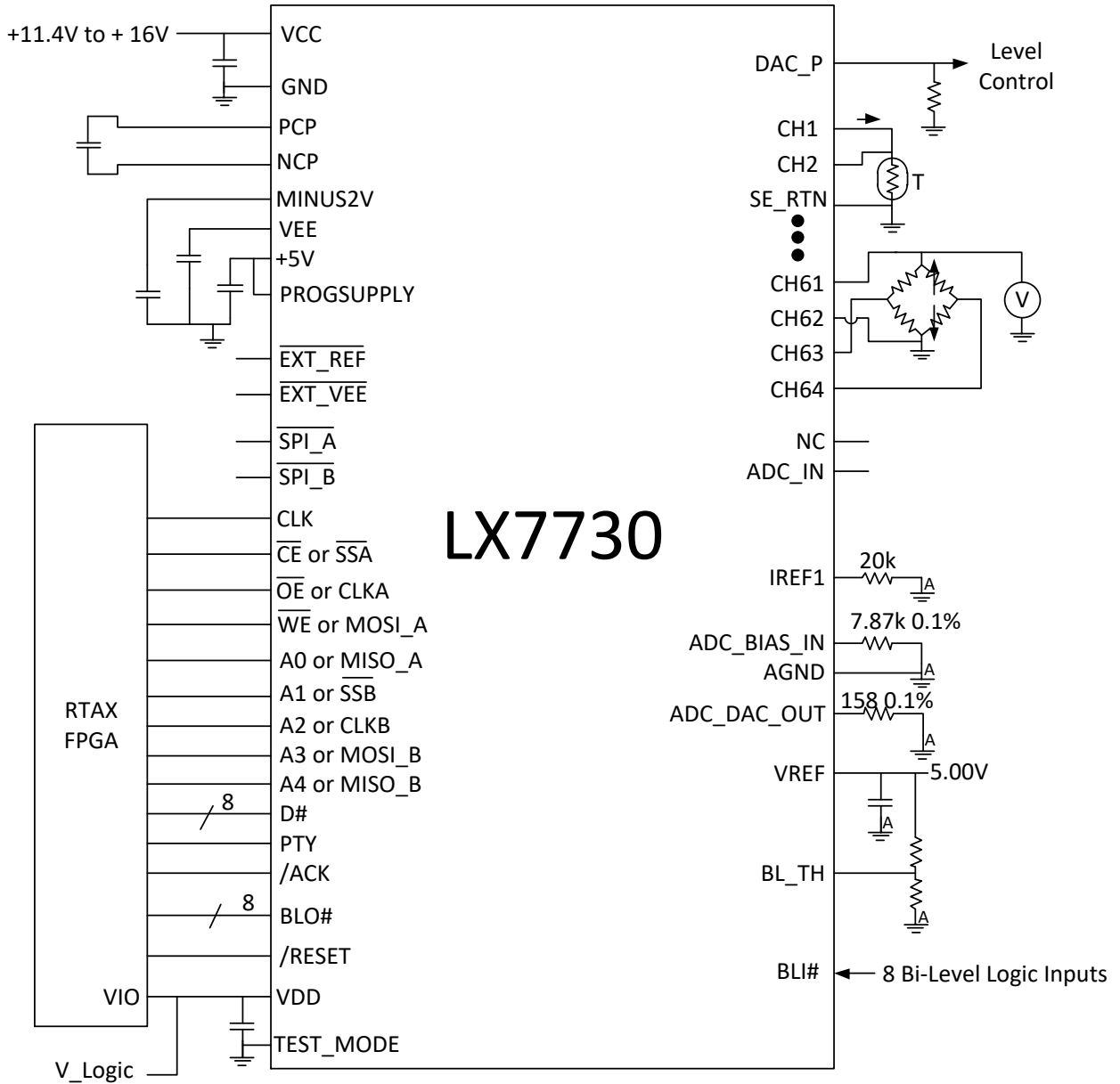

Figure 5 · Typical Application

Theory of Operation

Analog Multiplexer

The analog multiplexer (AMUX) consists of 64 inputs. There are two outputs which are the non-inverting and inverting inputs of the following instrumentation amplifier stage. Since the ADC processes only positive voltages, the input voltage at the non-inverting channel is expected to be greater than or equal to the inverting channel. The AMUX is physically divided into eight banks of eight inputs. Only one CH#, from one input bank can be selected at a time which means that differential measurements must consist of two CH#s from two different input banks. For a single ended input measurement, the common SE_RTN reference pin can be selected by asserting the appropriate bit in the inverting terminal AMUX register. The EN_BL SW POS bit of register 12 must be de-asserted to use the analog multiplexing registers (3 and 4). The address bits for the Analog MUX (registers 3 and 4) are shown in the table below.

		Pos 0	Pos 1	Pos 2	Pos 3	Pos 4	Pos 5	Pos 6	Pos 7
	Bits [2:0]	000	001	010	011	100	101	110	111
	Bits [5:3]								
Bank 0	000	CH1	CH9	CH17	CH25	CH33	CH41	CH49	CH57
Bank 1	001	CH2	CH10	CH18	CH26	CH34	CH42	CH50	CH58
Bank 2	010	CH3	CH11	CH19	CH27	CH35	CH43	CH51	CH59
Bank 3	011	CH4	CH12	CH20	CH28	CH36	CH44	CH52	CH60
Bank 4	100	CH5	CH13	CH21	CH29	CH37	CH45	CH53	CH61
Bank 5	101	CH6	CH14	CH22	CH30	CH38	CH46	CH54	CH62
Bank 6	110	CH7	CH15	CH23	CH31	CH39	CH47	CH55	CH63
Bank 7	111	CH8	CH16	CH24	CH32	CH40	CH48	CH56	CH64

Bi-Level Inputs with Adjustable Threshold

The 64 sensor inputs can also be used as bi-level detection inputs. The bi-level detection comparators monitor one position, simultaneously, from each of the input banks; the position is register selectable. The Bi-level MUX and the AMUX are not independent, the EN_BL SW POS bit of register 12 must be asserted to use the Bi-Level MUX. The selected eight bi-level inputs are compared to a common adjustable threshold that is developed using an 8 bit binary DAC. The outputs for the group of 8 are available in a register that is continuously updated and can be polled to monitor the status. The comparators are sampled during the clock cycle that the Bi-Level Status is read.

Differential Amplifier, Gain scaling, Anti-Aliasing Filter

The AMUX feeds directly into the inputs of an instrumentation amplifier with three selectable fixed gain settings (x0.4, x2 and x10) selectable using register 7. The Instrumentation Amplifier has a buffered output to drive the two pole anti-aliasing filter (AAF); the AAF poles can be set to 10kHz, 2kHz or 400Hz using register 7. The output of the AAF drives the ADC input. The output of the entire gain and filter stage is accessible at the ADC_IN pin. The ADC has a dynamic range of 0 to 2V and can be driven directly from the ADC_IN pin if the AAF is turned off using register 7 (AAF off) or register 8 (ADC_IN = HiZ).

The instrumentation amplifier on a gain setting of 0.4 has a relatively high slew rate; this requires a wait state for the IA output to settle for large signal level changes.

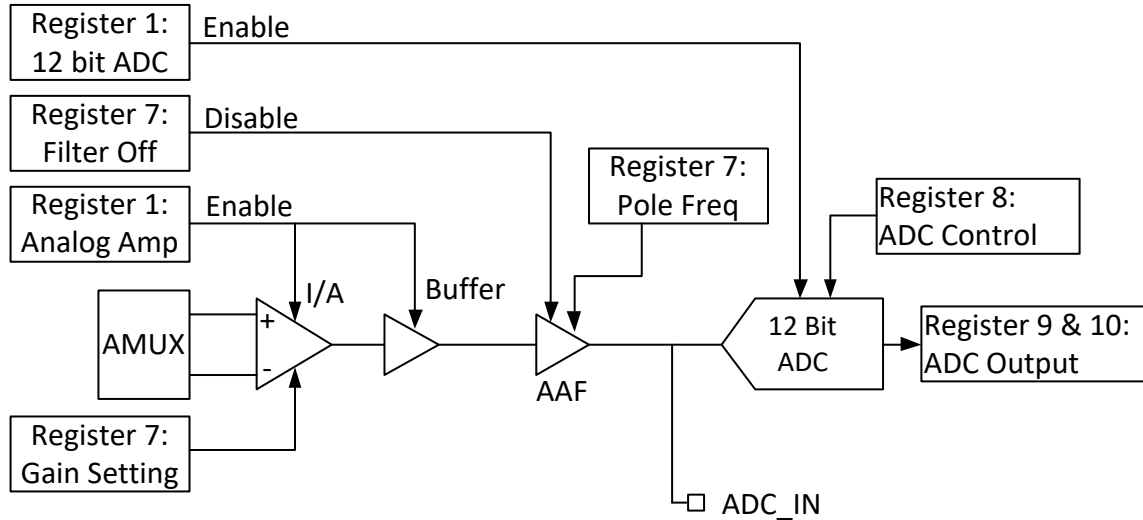

The table below indicates how to configure the amplifier and filter chain for various modes of operation.

Condition	12 bit ADC	Analog Amp	AAF off
Use entire chain: IA, buffer, AAF and ADC	on	on	on
Use ADC driven by ADC_IN	on	Don't care	off
Shut everything off to save maximum power	off	off	off

12 Bit ADC

The ADC uses a successive approximation register (SAR) design. The CLK input sequences the ADC logic. The specified linearity and offset error of the ADC is a result of fitting a straight line to the ADC response curve.

The ADC can be set to convert continuously or to convert on request using START CONVERT. Whenever a conversion is in process the BUSY status bit is asserted. When the conversion is complete the DATA READY bit is set.

If the continuous conversion is selected using the Auto Conv bit of register 8, the ADC values are updated continuously whether or not the registers are read.

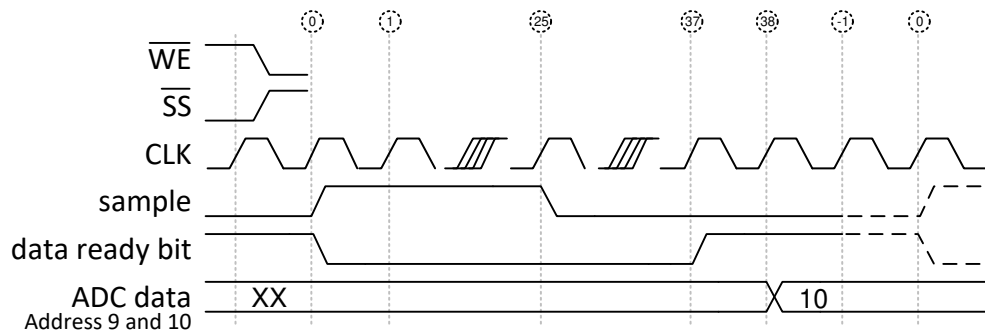

The ADC will start conversion at the rising edge of the CLK after the Start Conv bit is set. In parallel mode the Start Conv bit is set by the falling edge of /WE and in SPI mode it is set by the rising edge of /SS#.

The ADC samples the input for 25 clocks, and converts the sampled value for 12 clocks. The Data Ready bit is set after CLK 37. ADC Upper Byte, register 9, and ADC Lower Byte, register 10, are available for read after CLK 38.

If the Auto Conv bit is set and the Auto Sample Rate is set to 000, the next conversion will start 2 clocks after CLK 38.

10-bit Current DAC

The output of the DAC should be terminated in a resistor that is less than 1.5kΩ to insure the DAC stays within its compliance range. A parallel 1nF or greater capacitor can also be used to help reduce bit change glitches. The DAC has complementary outputs that are accomplished by steering the current between the two outputs based on the DAC setting. At zero LSBs, the DAC_N is full scale and DAC_P is off. The 10-bit Current DAC positive output, DAC_P should be open circuited and the negative output DAC_N can be connected to GND if the Use_DAC bit is asserted. (See current De-Mux description.)

Current De-Mux

The current de-mux routes a programmable current to whichever of the 64 CH inputs is selected. There are several modes of operation depending on the current amplitude required. The maximum current is available when the Use_DAC bit is de-asserted and the Double_Weight bit is asserted; this provides eight levels ranging from 500uA to 4mA. When both the Use_DAC and Double_Weight bits are de-asserted there are eight possible levels from 250uA to 2mA. When current source level is changed, the current source should be settled in its new position within 10us. If the Use_DAC bit is asserted, the 10bit DAC is used to set the de-mux current; each LSB has a weight of 10uA. A maximum of 300uA is suggested (code 31) when operating in this mode. The current de-mux can be shut off by asserting the Current Source Disable bit of register 1; the current De-MUX defaults to the off state at power up and must be enabled.

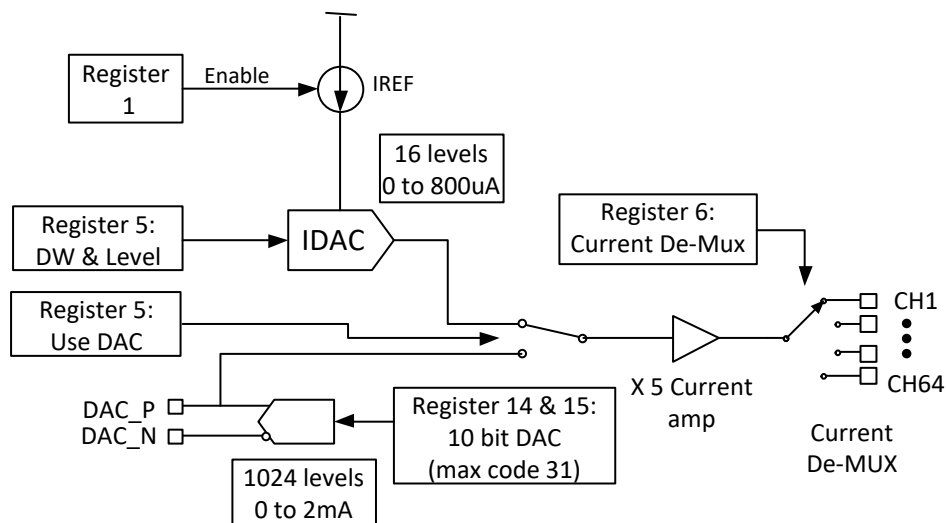

Fixed Bi-Level Inputs

There are eight fixed bi-level inputs with a 2.5V internal threshold setting common to all detectors. There is also a register selectable external threshold pin BL_TH where a threshold voltage can be programmed using a voltage divider to VREF that can be used in place of the internal reference. These logic threshold detected outputs go directly to output pins so they can be monitored directly

by the FPGA without the delay of the digital interface. A low pass filter and threshold hysteresis provides high frequency noise rejection.

Power On Reset

In Manual reset mode, the FPGA logically drives the RESET pin directly. The RESET pin should be asserted and released a few milliseconds after power is applied to place the registers in the default state. In auto-reset mode, a capacitor should be connected from RESET to GND to provide SEFI immunity and to program the reset time delay: the time delay from a valid VDD and internal 5V rail within the IC until the reset is released. The equation for this timing is:

$$DELAY = 35000 \times C_{RESET}$$

FPGA Interface

There are two options provided for the FPGA interface; either a single parallel interface or two SPI interfaces. Grounding either the SPI_A or SPI_B pin will select either of these interfaces; these pins have a 1MΩ pull-up to VDD. Only one interface can be active at any one time, but it is acceptable to switch between interfaces; this should only be done when the interface is idle or at rest. The LX7730 executes a command as soon as it has been received with the exception of the 10-bit DAC. The DAC output is updated when the upper byte MSB register is written to.

The LX7730 performs a simple even parity check on the combination of the address, data and PTY (parity) bits for parallel data and the combination of address, data, W/R and P (parity) for serial data. The W/R bit is high for a register write and low for a register read. If a parity error is discovered, the command will not execute and the /ACK pin is pulled high, see “Interface Timing” for /ACK output timing. Both SPI and parallel data transfers have even parity. The PTY line supports a parity bit for the parallel data transfers.

Interface Timing

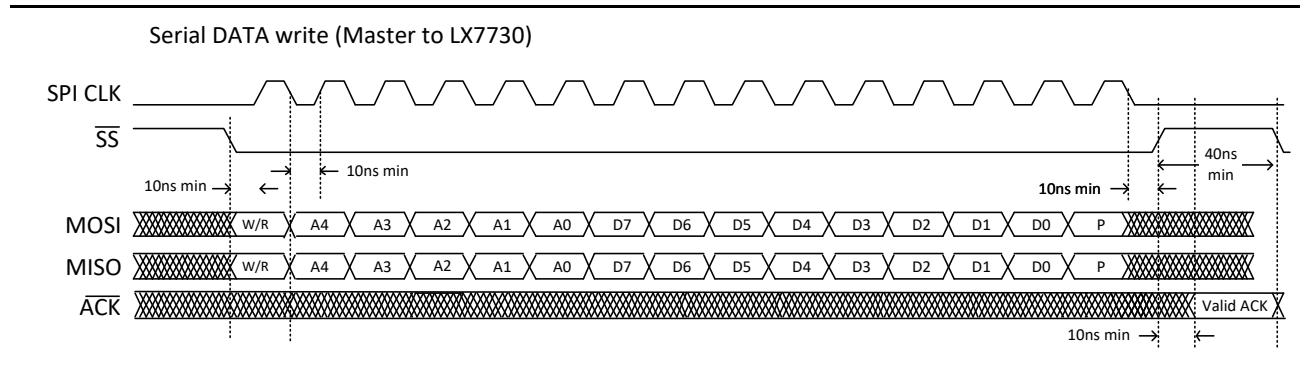

Figure 6 · Serial Data Write Timing Diagram

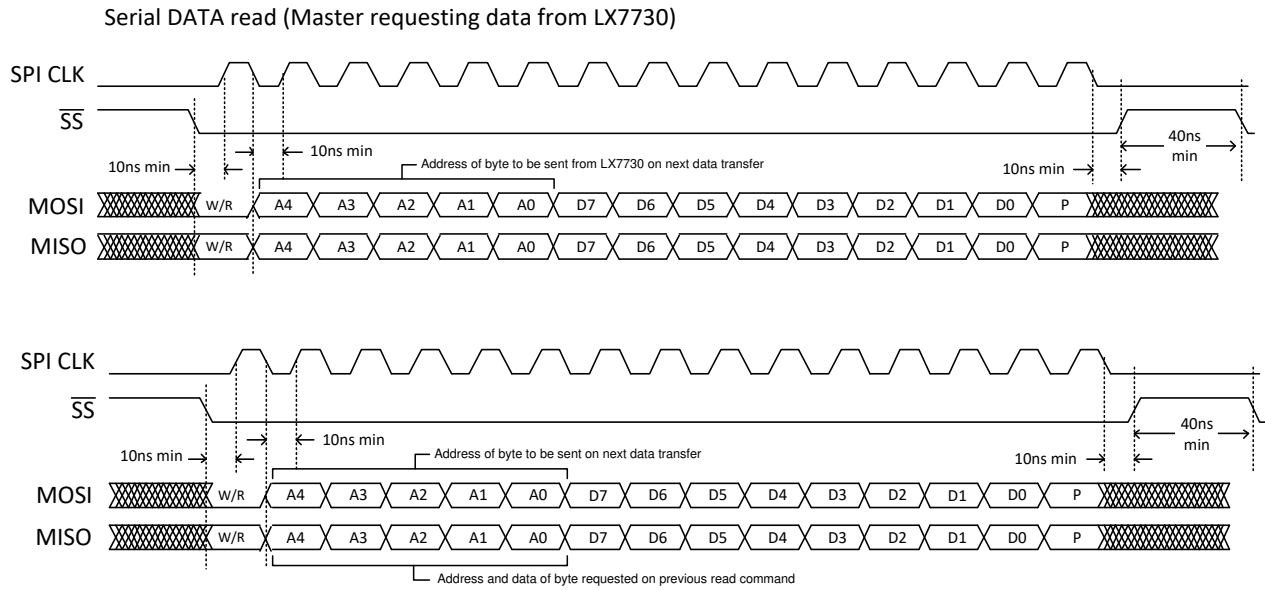
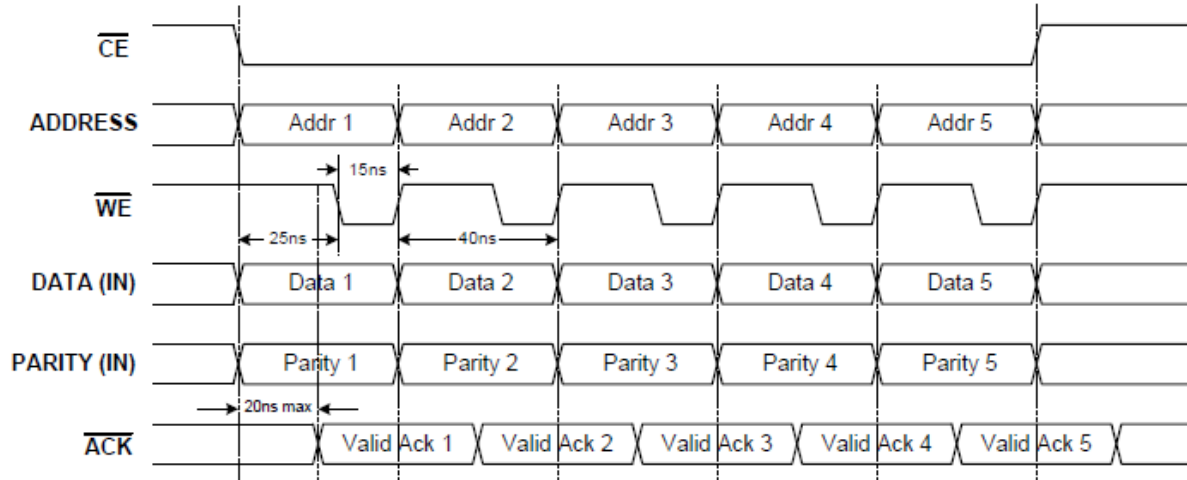

Figure 7 · Serial Data Read Timing Diagram

Parallel Write/Read Diagram (with minimum period of 40ns):

1. Successive DATA Write cycles (\overline{OE} remains high)



2. Successive DATA Read cycles (\overline{WE} remains high)

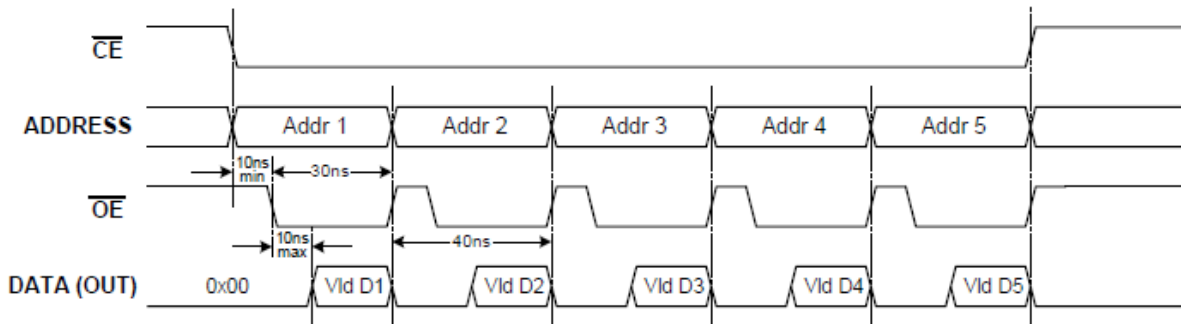

Figure 8 · Parallel Data Transfer Timing Diagram for Successive Data Transfers

Note: For “serial data write” /ACK output is valid after /SS rises. It will remain valid until the next time /SS is pulled low. For “parallel data write” the /ACK output is valid after the address, data, and PTY signals are stable. The /ACK output should be low while /CE is low for the data to be written to the registers

Register Descriptions

Register address 0: Master Reset

Register address 0 is used to perform a master reset which returns all internal registers to the power on (default) state. During the applied reset state, test signals are routed to BLO5 to 8. The mapping for this is: BLO5 = VCC UVLO, BLO6 = VEE UVLO, BLO7 = +5V UVLO, BLO8 = Power On Enable. To perform the master reset, the bit code 01101010 must be written to register 0; then, to restore normal operation a write to register 0 of another code (such as 00000000) is required.

Register address 1: Function Enable

The Function enable register provides the option to power down functions that are not used; the default would be to have everything active. The idea is to conserve power but only to the extent it can be done without affecting any of the functions that are still active.

Function Enable Register			
Bit #	Name	Default	Description
7	Chip Enable	1	If de-asserted everything but the active power supplies and digital interface to the FPGA is turned off but the internal register contents are preserved; this is a low power sleep mode. CH# and BLI# and DAC pins are cold spared. If de-asserted, functions corresponding to bits 0 thru 6 are disabled.
6	Sensor MUX	1	If de-asserted, all CH switching and routing (Analog or Bi-Level) is turned off. CH# pins are cold spared.
5	Current Source Disable	1	If asserted, the multiplexed current source directed to a CH# pin is not used and powered down. If de-asserted, the multiplexed current source is enabled and directed to the CH# defined in register 6
4	Bi-level comp	1	If de-asserted, power is removed from the bi-level comparators but doing so does not affect the functionality of the Analog Multiplexer and ADC.
3	Analog Amplifiers	1	If de-asserted, the instrumentation amplifier and buffer driving the AAF are powered down. The ADC and Bi-level comparators are not affected. However, the ADC must be driven by an external signal using ADC_IN pin (with Filter Off bit asserted or ADC=Hi Z asserted).
2	10 Bit DAC	1	If de-asserted, the 10-bit DAC is not used and powered down. DAC outputs are cold spared.
1	Fixed Bi-Level	1	If de-asserted, the Fixed Bi-level converters are not used and powered down. BLI# inputs are cold spared.
0	12 Bit ADC	1	If de-asserted, the 12-bit ADC is not used and powered down.

Register address 2: Power Status

The Power Status register provides the option to check for a UVLO condition or to monitor the power rails. There is also a bit for selection of the redundant IREF pin.

Power Status Register

Bit #	Name	Default	Description
7	Use IREF2	0	If asserted, IREF2 is used to set the reference current instead of the resistor attached to IREF1.
6	Monitor VCC	0	If asserted, this action overrides the setting of the register of address 3 and routes VCC pin divided by 6 to the non-inverting terminal of the IA (instrumentation amplifier). It overrides the setting of the address 4 register and applies GND to the inverting terminal of the IA.
5	Monitor VEE	0	If asserted, this action overrides the setting of the register of address 4 and routes VEE pin divided by 6 to the inverting terminal of the IA (instrumentation amplifier). It overrides the setting of the address 3 register and applies GND to the non-inverting terminal of the IA.
4	Monitor +5V	0	If asserted, this action overrides the setting of the register of address 3 and routes +5V pin divided by 2 to the non-inverting terminal of the IA (instrumentation amplifier). It overrides the setting of the address 4 register and applies GND to the inverting terminal of the IA.
3	Monitor VREF	0	If asserted, this action overrides the setting of the register of address 3 and routes VREF pin divided by 2 to the non-inverting terminal of the IA (instrumentation amplifier). It overrides the setting of the address 4 register and applies GND to the inverting terminal of the IA.
2	VCC UVLO	0	Asserted by the LX7730 if VCC is below the UVLO threshold.
1	VEE UVLO	0	Asserted by the LX7730 if VEE is below the UVLO threshold.
0	+5V UVLO	0	Asserted by the LX7730 if the +5V is below the UVLO threshold.

Register address 3: Non-Inverting MUX Channel Select

The Non-Inverting MUX Channel Select register is used to select the CH# pin that is routed by the analog MUX to the non-inverting pin of the Instrumentation amplifier.

Non-Inverting MUX Channel Select Register

Bit #	Name	Default	Description
6 - 7	Not Used	0	
5	Bank D2	0	These 6 bits are used to select an input channel. Bits 3 to 5 are used to select the bank and bits 0 to 2 are used to select the position. The conversion of bank/position to CH# follows this equation: $CH\# = (\text{Reg } [2:0] \times 8) + \text{Reg } [5:3] + 1$ For example, to route CH11 to the non-inverting terminal of the instrumentation amplifier, the value in register 3 would be 00-010-001.
4	Bank D1	0	
3	Bank D0	0	
2	Position D2	0	
1	Position D1	0	
0	Position D0	0	

Register address 4: Inverting MUX Channel Select

The Inverting MUX Channel Select register is used to select the CH# pin that is routed by the analog MUX to the inverting pin of the Instrumentation amplifier. There is also a bit (Use SE_RTN, bit 6, that when asserted, overrides the value determined by bits D5 to D0 and instead of selecting an CH# pin, connects the SE_RTN input pin to the inverting pin of the instrumentation amplifier.

Inverting MUX Channel Select Register			
Bit #	Name	Default	Description
7	Not Used	0	
6	Use SE_RTN	0	If asserted, this bit routes the SE_RTN pin to the inverting terminal of the instrumentation amplifier.
5	Bank D2	0	These 6 bits are used to select an input channel. Bits 3 to 5 are used to select the bank and bits 0 to 2 are used to select the position. The conversion of bank/position to CH# follows this equation: $CH\# = (\text{Reg } [2:0] \times 8) + \text{Reg } [5:3] + 1$ For example, to route CH11 to the inverting terminal of the instrumentation amplifier, the value in register 3 would be 00-010-001.
4	Bank D1	0	
3	Bank D0	0	
2	Position D2	0	
1	Position D1	0	
0	Position D0	0	

Register address 5: Current MUX Level

The Current MUX level register is used to set the current in the programmable current source. Only the lower four LSBs are used since there are only sixteen possible levels. Bit 3, when asserted, doubles the current source reference current which doubles the weight of each output current setting.

Current De-MUX Level Register			
Bit #	Name	Default	Description
7	Use DAC	0	When asserted the 10-bit DAC is used to program the current for the current De-Mux. The current output will be 5 X the 10-bit DAC DAC_P output. The DAC_P output will also be disabled. (1)
4 - 6	Not Used	0	Not Used
3	Double Weight	0	When asserted, this bit doubles the weight of the current source as determined by bits D2 to D0.
2	D2 (MSB)	0	These 3 bits are used to select the amplitude of the programmable current source. Their binary value (BV) represents a number from 0 to 7. If bit D3 is not asserted, the current source output is $(BV + 1) \times 250\mu\text{A}$. If bit D3 is asserted the current source output is $2 \times (BV+1) \times 250\mu\text{A}$.
1	D1	0	
0	D0 (LSB)	0	

(1) DAC_N should still have an impedance of 1.5KΩ or less to ground

Register address 6: Current MUX Channel Selection

The Current MUX Select register is used to route the current source to one of the 64 input channels (CH#).

Current MUX Channel Selection Register

Bit #	Name	Default	Description
6 - 7	Not Used	0	Not Used
5	D5 (MSB)	0	These 6 bits are used to select an input channel. Their binary value represents a number from 0 to 63. The CH# pin selected is their binary value plus 1. For example, value D5 to D0 = 011011 or binary 27 will route the output of the programmable current source to CH28.
4	D4	0	
3	D3	0	
2	D2	0	
1	D1	0	
0	D0 (LSB)	0	

Register address 7: Signal Conditioning Amplifier

The Signal Conditioning Amplifier register controls the gain and pole location for the signal conditioning amplifier located between the output of the instrumentation amplifier and the input to the ADC. It can be shut off to facilitate bypassing or using external signal.

Signal Conditioning Amplifier Register

Bit #	Name	Default	Description
7	Not Used	0	Not Used
6	AAF off	0	If de-asserted (and ADC=HiZ is also de-asserted), the AAF amplifier is fully functional and the output of the AAF drives the ADC input with a low impedance driver. When asserted, the AAF filter is off and the ADC can be driven from ADC_IN.
5	Second Pole Frequency MSB	0	These two pins are used to select the pole frequency for a single pole response for one of two possible single pole filters. The frequency settings are [D5, D4] = 00, 01, 10 for 400, 2k, 10k in Hertz, respectively (setting 11 is not used).
4	Second Pole Frequency LSB	0	
3	First Pole Frequency MSB	0	These two pins are used to select the pole frequency for a single pole response for one of two possible single pole filters. The frequency settings are [D3, D2] = 00, 01, 10 for 400, 2k, 10k in Hertz, respectively (setting 11 is not used).
2	First Pole Frequency LSB	0	
1	Gain Setting MSB	0	These two pins are used to select the gain setting for the amplifier channel. The gain settings are [D1, D0] = 00, 01, 10 for a gain of 0.4, 2.0, or 10. The [D1,D0] = 11 setting is not used (but also sets a gain of 10).
0	Gain Setting LSB	0	