



Chipsmall Limited consists of a professional team with an average of over 10 year of expertise in the distribution of electronic components. Based in Hongkong, we have already established firm and mutual-benefit business relationships with customers from,Europe,America and south Asia,supplying obsolete and hard-to-find components to meet their specific needs.

With the principle of “Quality Parts,Customers Priority,Honest Operation,and Considerate Service”,our business mainly focus on the distribution of electronic components. Line cards we deal with include Microchip,ALPS,ROHM,Xilinx,Pulse,ON,Everlight and Freescale. Main products comprise IC,Modules,Potentiometer,IC Socket,Relay,Connector.Our parts cover such applications as commercial,industrial, and automotives areas.

We are looking forward to setting up business relationship with you and hope to provide you with the best service and solution. Let us make a better world for our industry!



Contact us

Tel: +86-755-8981 8866 Fax: +86-755-8427 6832

Email & Skype: info@chipsmall.com Web: www.chipsmall.com

Address: A1208, Overseas Decoration Building, #122 Zhenhua RD., Futian, Shenzhen, China



DUAL FREQUENCY VOLTAGE-CONTROLLED CRYSTAL OSCILLATOR (VCXO) 10 TO 810 MHz

Features

- Available with any-rate output frequencies from 10 to 810 MHz
- Two selectable output frequencies
- 3rd generation DSPLL[®] with superior jitter performance
- Internal fixed fundamental mode crystal frequency ensures high reliability and low aging
- Available CMOS, LVPECL, LVDS, and CML outputs
- 3.3, 2.5, and 1.8 V supply options
- Industry standard 5x7 and 3.2x5 mm packages
- Pb-free/RoHS-compliant
- -40 to +85 °C operating range

Applications

- SONET/SDH (OC-3/12/48)
- Networking
- SD/HD SDI/3G SDI video
- FTTx
- Clock recovery and jitter cleanup PLLs
- FPGA/ASIC clock generation

Description

The Si596 dual-frequency VCXO utilizes Silicon Laboratories' advanced DSPLL[®] circuitry to provide a low-jitter clock at high frequencies. The Si596 is available with any-rate output frequency from 10 to 810 MHz. Unlike traditional VCXOs, where a different crystal is required for each output frequency, the Si596 uses one fixed crystal to provide a wide range of output frequencies. This IC-based approach allows the crystal resonator to provide exceptional frequency stability and reliability. In addition, DSPLL clock synthesis provides supply noise rejection, simplifying the task of generating low-jitter clocks in noisy environments. The Si596 IC-based VCXO is factory-configurable for a wide variety of user specifications including frequency, supply voltage, output format, tuning slope, and absolute pull range (APR). Specific configurations are factory programmed at time of shipment, thereby eliminating the long lead times associated with custom oscillators.

Functional Block Diagram

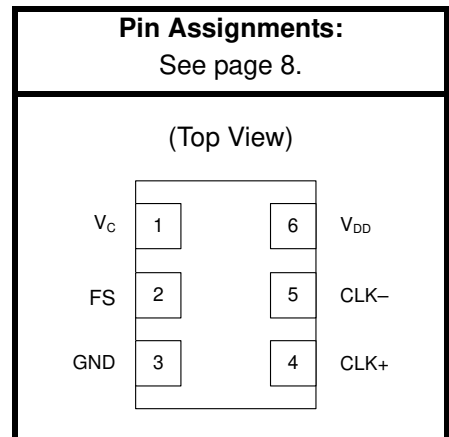
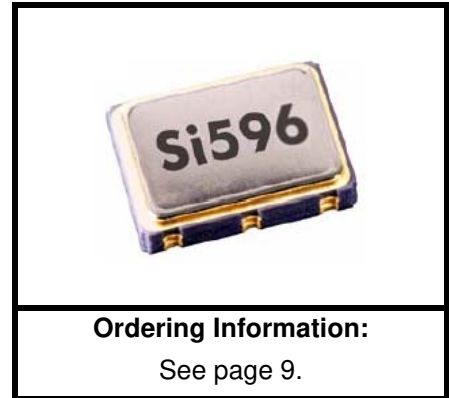
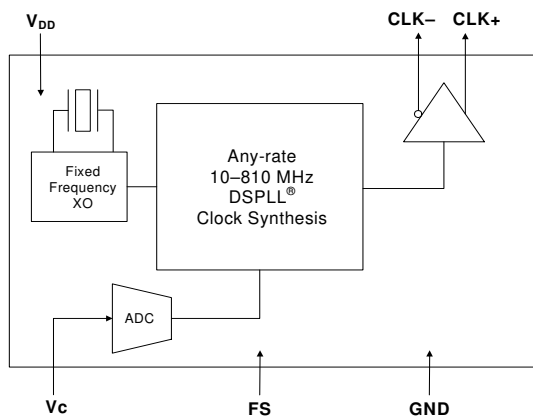

TABLE OF CONTENTS

<u>Section</u>	<u>Page</u>
1. Electrical Specifications	3
2. Pin Descriptions	8
3. Ordering Information	9
4. Package Outline Diagram: 5 x 7 mm, 6-pin	10
5. PCB Land Pattern: 5 x 7 mm, 6-pin	11
6. Package Outline Drawing: 3.2 x 5 mm, 6-pin	12
7. PCB Land Pattern: 3.2 x 5 mm, 6-pin	13
8. Si596 Top Marking: 5x7 mm	14
9. Si596 Top Marking: 3.2x5 mm	15
Revision History	16

1. Electrical Specifications

Table 1. Recommended Operating Conditions

Parameter	Symbol	Test Condition	Min	Typ	Max	Units
Supply Voltage ¹	V_{DD}	3.3 V option	2.97	3.3	3.63	V
		2.5 V option	2.25	2.5	2.75	
		1.8 V option	1.71	1.8	1.89	
Supply Current	I_{DD}	LVPECL	—	120	135	mA
		CML	—	110	120	
		LVDS	—	100	110	
		CMOS	—	90	100	
Frequency Select (FS) ²		V_{IH}	$0.75 \times V_{DD}$	—	—	V
		V_{IL}	—	—	0.5	
Operating Temperature Range	T_A		−40	—	85	°C

Notes:

- Selectable parameter specified by part number. See 3. "Ordering Information" on page 9 for further details.
- FS pin includes an internal 17 k Ω pullup resistor to V_{DD} . When the FS is left floating, the pullup causes FS = 1 = second frequency selected.

Table 2. V_C Control Voltage Input

Parameter	Symbol	Test Condition	Min	Typ	Max	Units
Control Voltage Tuning Slope ^{1,2,3}	K_V	10 to 90% of V_{DD}	—	45	—	ppm/V
				95		
				125		
				185		
				380		
Control Voltage Linearity ⁴	L_{VC}	BSL	−5	± 1	+5	%
		Incremental	−10	± 5	+10	
Modulation Bandwidth	BW		9.3	10.0	10.7	kHz
V_C Input Impedance	Z_{VC}		500	—	—	k Ω
V_C Input Capacitance	C_{VC}		—	50	—	pF
Nominal Control Voltage	V_{CNOM}	@ f_0	—	$V_{DD}/2$	—	V
Control Voltage Tuning Range	V_C		0		V_{DD}	V

Notes:

- Positive slope; selectable option by part number. See 3. "Ordering Information" on page 9.
- For best jitter and phase noise performance, always choose the smallest K_V that meets the application's minimum APR requirements. See "AN266: VCXO Tuning Slope (K_V), Stability, and Absolute Pull Range (APR)" for more information.
- K_V variation is $\pm 10\%$ of typical values.
- BSL determined from deviation from best straight line fit with V_C ranging from 10 to 90% of V_{DD} . Incremental slope determined with V_C ranging from 10 to 90% of V_{DD} .

Table 3. CLK± Output Frequency Characteristics

Parameter	Symbol	Test Condition	Min	Typ	Max	Units
Nominal Frequency ^{1,2,3}	f _O	LVDS/CML/LVPECL	10	—	810	MHz
		CMOS	10	—	160	
Temperature Stability ^{1,4}		T _A = -40 to +85 °C	-20 -50	— —	+20 +50	ppm
Absolute Pull Range ^{1,4}	APR		±10	—	±370	ppm
Power up Time ⁵	t _{OSC}		—	—	10	ms
Settling Time After FS Change	T _{FRQ}		—	—	10	ms

Notes:

1. See Section 3. "Ordering Information" on page 9 for further details.
2. Specified at time of order by part number.
3. Nominal output frequency set by V_{CNOM} = V_{DD}/2.
4. Selectable parameter specified by part number.
5. Time from power up or tristate mode to f_O.

Table 4. CLK± Output Levels and Symmetry

Parameter	Symbol	Test Condition	Min	Typ	Max	Units
LVPECL Output Option ¹	V _O	mid-level	V _{DD} - 1.42	—	V _{DD} - 1.25	V
	V _{OD}	swing (diff)	1.1	—	1.9	V _{PP}
	V _{SE}	swing (single-ended)	0.55	—	0.95	V _{PP}
LVDS Output Option ²	V _O	mid-level	1.125	1.20	1.275	V
	V _{OD}	swing (diff)	0.5	0.7	0.9	V _{PP}
CML Output Option ²	V _O	2.5/3.3 V option mid-level	—	V _{DD} - 1.30	—	V
		1.8 V option mid-level	—	V _{DD} - 0.36	—	
	V _{OD}	2.5/3.3 V option swing (diff)	1.10	1.50	1.90	V _{PP}
		1.8 V option swing (diff)	0.35	0.425	0.50	
CMOS Output Option ³	V _{OH}		0.8 x V _{DD}	—	V _{DD}	V
	V _{OL}		—	—	0.4	
Rise/Fall time (20/80%)	t _R , t _F	LVPECL/LVDS/CML	—	—	350	ps
		CMOS with C _L = 15 pF	—	2	—	ns
Symmetry (duty cycle)	SYM	LVPECL: V _{DD} - 1.3 V (diff) LVDS: 1.25 V (diff) CMOS: V _{DD} /2	45	—	55	%

Notes:

1. 50 Ω to V_{DD} - 2.0 V.
2. R_{term} = 100 Ω (differential).
3. C_L = 15 pF. Sinking or sourcing 12 mA for V_{DD} = 3.3 V, 6 mA for V_{DD} = 2.5 V, 3 mA for V_{DD} = 1.8 V.

Table 5. CLK± Output Phase Jitter

Parameter	Symbol	Test Condition	Min	Typ	Max	Units
Phase Jitter (RMS) ^{1,2} for F_{OUT} of $50 \text{ MHz} \leq F_{OUT} \leq 810 \text{ MHz}$	ϕ_J	$K_V = 45 \text{ ppm/V}$ 12 kHz to 20 MHz	—	0.5	—	ps
		$K_V = 95 \text{ ppm/V}$ 12 kHz to 20 MHz	—	0.5	—	
		$K_V = 125 \text{ ppm/V}$ 12 kHz to 20 MHz	—	0.5	—	
		$K_V = 185 \text{ ppm/V}$ 12 kHz to 20 MHz	—	0.5	—	
		$K_V = 380 \text{ ppm/V}$ 12 kHz to 20 MHz	—	0.7	—	

Notes:

1. Refer to AN256 for further information.
2. For best jitter and phase noise performance, always choose the smallest K_V that meets the application's minimum APR requirements. See "AN266: VCXO Tuning Slope (K_V), Stability, and Absolute Pull Range (APR)" for more information.

Table 6. CLK± Output Period Jitter

Parameter	Symbol	Test Condition	Min	Typ	Max	Units
Period Jitter*	J_{PER}	RMS	—	3	—	ps
		Peak-to-Peak	—	35	—	

*Note: Any output mode, including CMOS, LVPECL, LVDS, CML. N = 1000 cycles. Refer to AN279 for further information.

Table 7. CLK± Output Phase Noise (Typical)

Offset Frequency	74.25 MHz 185 ppm/V LVPECL	148.5 MHz 185 ppm/V LVPECL	155.52 MHz 95 ppm/V LVPECL	Units
100 Hz	-77	-68	-77	dBc/Hz
1 kHz	-101	-95	-101	
10 kHz	-121	-116	-119	
100 kHz	-134	-128	-127	
1 MHz	-149	-144	-144	
10 MHz	-151	-147	-147	
20 MHz	-150	-148	-148	

Table 8. Environmental Compliance and Package Information

Parameter	Conditions/Test Method
Mechanical Shock	MIL-STD-883, Method 2002
Mechanical Vibration	MIL-STD-883, Method 2007
Solderability	MIL-STD-883, Method 2003
Gross and Fine Leak	MIL-STD-883, Method 1014
Resistance to Solder Heat	MIL-STD-883, Method 2036
Contact Pads	Gold over Nickel

Table 9. Thermal Characteristics

(Typical values $T_A = 25\text{ }^\circ\text{C}$, $V_{DD} = 3.3\text{ V}$)

Parameter	Symbol	Test Condition	Min	Typ	Max	Unit
5x7mm, Thermal Resistance Junction to Ambient	θ_{JA}	Still Air	—	84.6	—	$^\circ\text{C/W}$
5x7mm, Thermal Resistance Junction to Case	θ_{JC}	Still Air	—	38.8	—	$^\circ\text{C/W}$
3.2x5mm, Thermal Resistance Junction to Ambient	θ_{JA}	Still Air	—	31.1	—	$^\circ\text{C/W}$
3.2x5mm, Thermal Resistance Junction to Case	θ_{JC}	Still Air	—	13.3	—	$^\circ\text{C/W}$
Ambient Temperature	T_A		-40	—	85	$^\circ\text{C}$
Junction Temperature	T_J		—	—	125	$^\circ\text{C}$

Table 10. Absolute Maximum Ratings¹

Parameter	Symbol	Rating	Units
Maximum Operating Temperature	T_{AMAX}	85	$^\circ\text{C}$
Supply Voltage	V_{DD}	-0.5 to +3.8	V
Input Voltage	V_I	-0.5 to $V_{DD} + 0.3$	
Storage Temperature	T_S	-55 to +125	$^\circ\text{C}$
ESD Sensitivity (HBM, per JESD22-A114)	ESD	2500	V
Soldering Temperature (Pb-free profile) ²	T_{PEAK}	260	$^\circ\text{C}$

Table 10. Absolute Maximum Ratings¹

Parameter	Symbol	Rating	Units
Soldering Temperature Time @ T _{PEAK} (Pb-free profile) ²	t _p	20–40	seconds
Notes: <ol style="list-style-type: none">1. Stresses beyond those listed in Absolute Maximum Ratings may cause permanent damage to the device. Functional operation or specification compliance is not implied at these conditions. Exposure to maximum rating conditions for extended periods may affect device reliability.2. The device is compliant with JEDEC J-STD-020C. Refer to Si5xx Packaging FAQ available for download from www.silabs.com/VCXO for further information, including soldering profiles.			

2. Pin Descriptions

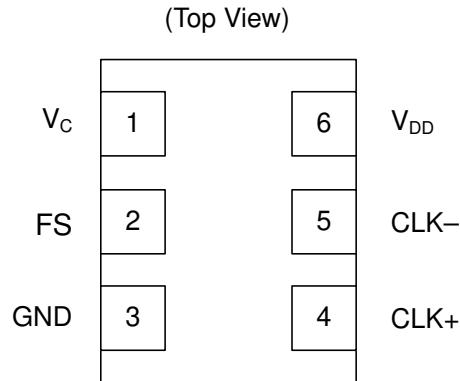

Table 11. Si596 Pin Descriptions

Pin	Name	Type	Function
1	V_C	Analog Input	Control Voltage
2	FS*	Input	Frequency Select: 0 = first frequency selected 1 = second frequency selected
3	GND	Ground	Electrical and Case Ground
4	CLK+	Output	Oscillator Output
5	CLK- (N/C for CMOS)	Output	Complementary Output (N/C for CMOS, do not make external connection)
6	V_{DD}	Power	Power Supply Voltage

***Note:** FS pin includes a 17 k Ω resistor to V_{DD} . When the FS is left floating, the pullup causes FS = 1 = second frequency selected. See 3. "Ordering Information" on page 9 for details on frequency select ordering options.

3. Ordering Information

The Si596 supports a variety of options including frequency, temperature stability, tuning slope, output format, and V_{DD} . Specific device configurations are programmed into the Si596 at time of shipment. Configurations are specified using the Part Number Configuration chart shown below. Silicon Labs provides a web browser-based part number configuration utility to simplify this process. To access this tool refer to www.silabs.com/oscillators and click "Customize" in the product table. The Si596 VCXO series is supplied in industry-standard, RoHS compliant, lead-free, 6-pad, 5 x 7 mm and 3.2 x 5 mm packages. Tape and reel packaging is an ordering option.

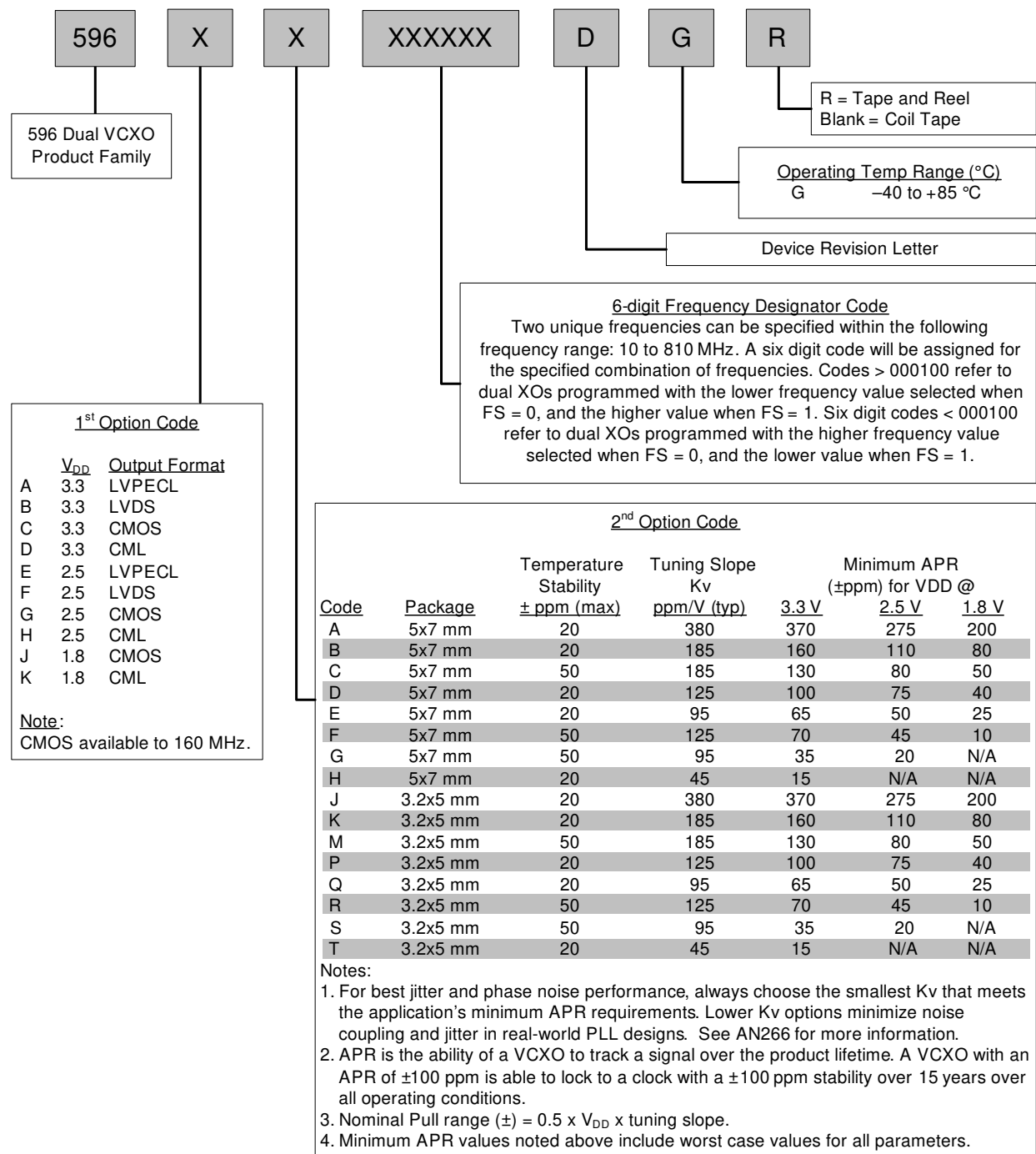

Figure 1. Part Number Convention

4. Package Outline Diagram: 5 x 7 mm, 6-pin

Figure 2 illustrates the package details for the 5 x 7 mm Si596. Table 12 lists the values for the dimensions shown in the illustration.

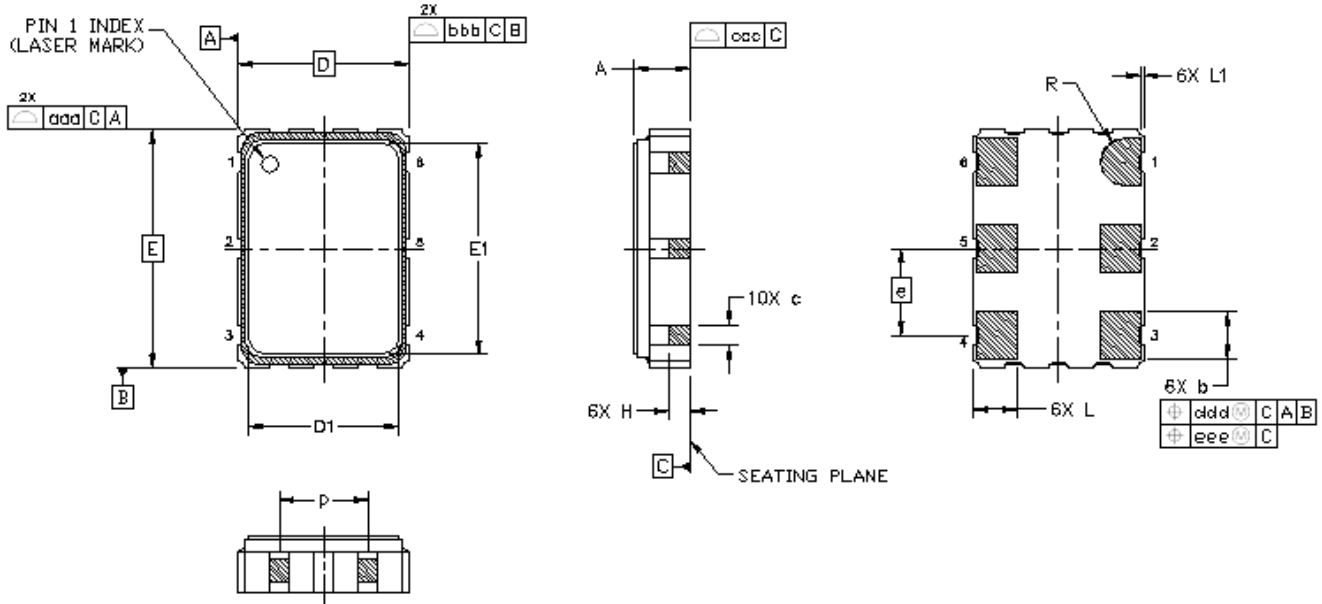

Figure 2. Si596 Outline Diagram

Table 12. Package Diagram Dimensions (mm)

Dimension	Min	Nom	Max
A	1.50	1.65	1.80
b	1.30	1.40	1.50
c	0.50	0.60	0.70
D	5.00 BSC		
D1	4.30	4.40	4.50
e	2.54 BSC.		
E	7.00 BSC.		
E1	6.10	6.20	6.30
H	0.55	0.65	0.75
L	1.17	1.27	1.37
L1	0.05	0.10	0.15
p	1.80	—	2.60
R	0.70 REF		
aaa	0.15		
bbb	0.15		
ccc	0.10		
ddd	0.10		
eee	0.05		

5. PCB Land Pattern: 5 x 7 mm, 6-pin

Figure 3 illustrates the 6-pin PCB land pattern for the 5 x 7 mm Si596. Table 13 lists the values for the dimensions shown in the illustration.

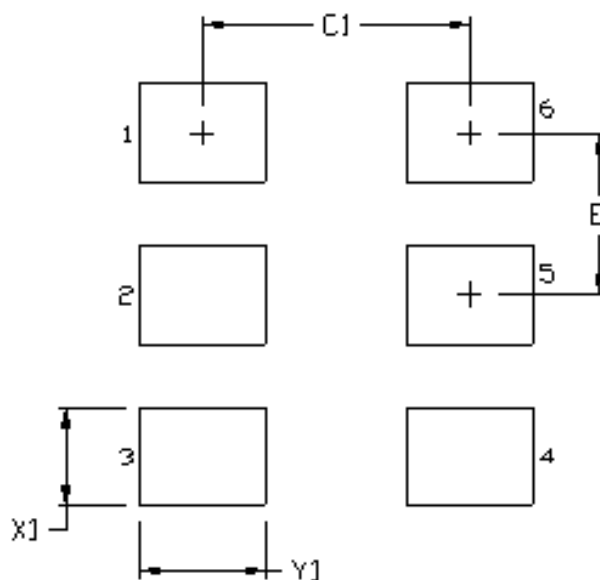

Figure 3. Si596 PCB Land Pattern

Table 13. PCB Land Pattern Dimensions (mm)

Dimension	(mm)
C1	4.20
E	2.54
X1	1.55
Y1	1.95

Notes:

General

1. All dimensions shown are in millimeters (mm) unless otherwise noted.
2. Dimensioning and Tolerancing is per the ANSI Y14.5M-1994 specification.
3. This Land Pattern Design is based on the IPC-7351 guidelines.
4. All dimensions shown are at Maximum Material Condition (MMC). Least Material Condition (LMC) is calculated based on a Fabrication Allowance of 0.05 mm.

Solder Mask Design

1. All metal pads are to be non-solder mask defined (NSMD). Clearance between the solder mask and the metal pad is to be 60 μm minimum, all the way around the pad.

Stencil Design

1. A stainless steel, laser-cut and electro-polished stencil with trapezoidal walls should be used to assure good solder paste release.
2. The stencil thickness should be 0.125 mm (5 mils).
3. The ratio of stencil aperture to land pad size should be 1:1.

Card Assembly

1. A No-Clean, Type-3 solder paste is recommended.
2. The recommended card reflow profile is per the JEDEC/IPC J-STD-020 specification for Small Body Components.

Si596

6. Package Outline Drawing: 3.2 x 5 mm, 6-pin

Figure 4 illustrates the package details for the 3.2 x 5 mm Si596. Table 14 lists the values for the dimensions shown in the illustration.

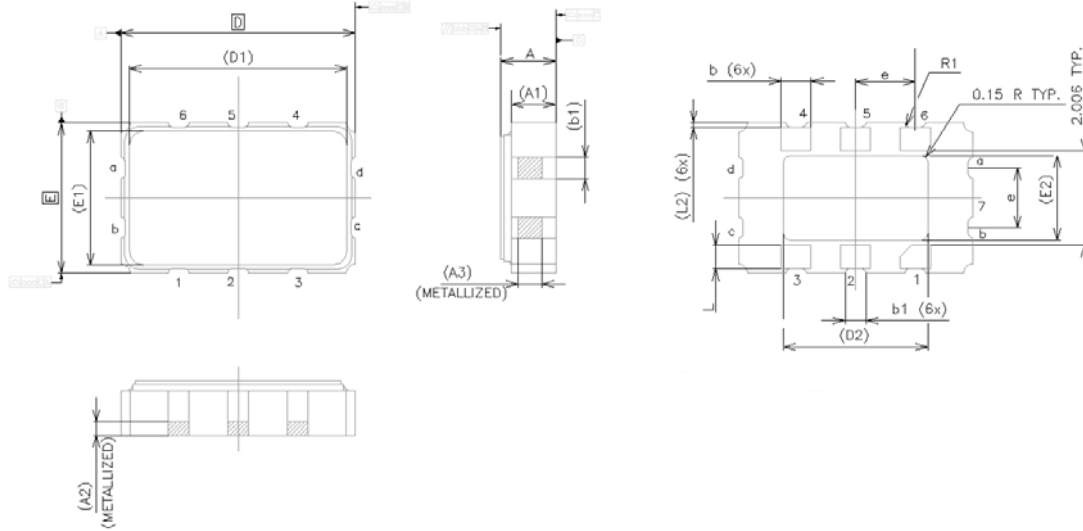

Figure 4. Si596 Outline Diagram

Table 14. Package Diagram Dimensions (mm)

Dimension	Min	Nom	Max	Dimension	Min	Nom	Max
A	1.02	1.17	1.32	E1	2.85 BSC		
A1	0.99	1.10	1.21	E2	1.91 BSC		
A2	0.5 BSC			L	0.35	0.45	0.55
A3	0.30 BSC			L2	0.05	0.10	0.15
b	0.54	0.64	0.74	R1	0.10 REF		
B1	0.35	0.45	0.55	aaa	0.15		
D	5.00 BSC			bbb	0.15		
D1	4.65 BSC			ccc	0.08		
D2	3.38 BSC			ddd	0.10		
e	1.27 BSC			eee	0.05		
E	3.20 BSC						

Notes:

1. All dimensions shown are in millimeters (mm) unless otherwise noted.
2. Dimensioning and Tolerancing per ANSI Y14.5M-1994.

7. PCB Land Pattern: 3.2 x 5 mm, 6-pin

Figure 5 illustrates the 6-pin PCB land pattern for the 3.2 x 5 mm Si596. Table 15 lists the values for the dimensions shown in the illustration.

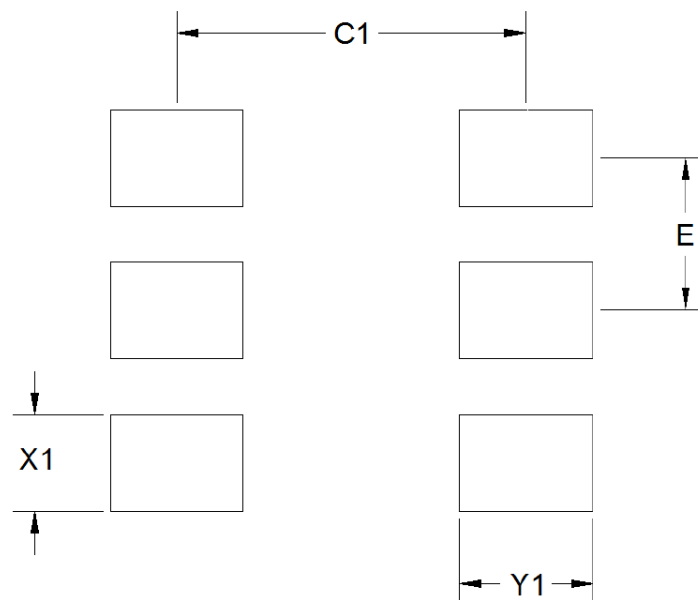

Figure 5. Si596 PCB Land Pattern

Table 15. PCB Land Pattern Dimensions (mm)

Dimension	(mm)
C1	2.91
E	1.27
X1	0.80
Y1	1.10

Notes:

General

1. All dimensions shown are in millimeters (mm) unless otherwise noted.
2. Dimensioning and Tolerancing is per the ANSI Y14.5M-1994 specification.
3. This Land Pattern Design is based on the IPC-7351 guidelines.
4. All dimensions shown are at Maximum Material Condition (MMC). Least Material Condition (LMC) is calculated based on a Fabrication Allowance of 0.05 mm.

Solder Mask Design

1. All metal pads are to be non-solder mask defined (NSMD). Clearance between the solder mask and the metal pad is to be 60 μm minimum, all the way around the pad.

Stencil Design

1. A stainless steel, laser-cut and electro-polished stencil with trapezoidal walls should be used to assure good solder paste release.
2. The stencil thickness should be 0.125 mm (5 mils).
3. The ratio of stencil aperture to land pad size should be 1:1.

Card Assembly

1. A No-Clean, Type-3 solder paste is recommended.
2. The recommended card reflow profile is per the JEDEC/IPC J-STD-020C specification for Small Body Components.

Si596

8. Si596 Top Marking: 5x7 mm

Si596. Table 16 lists the line information.

Figure 6 illustrates the mark specification for the 5x7

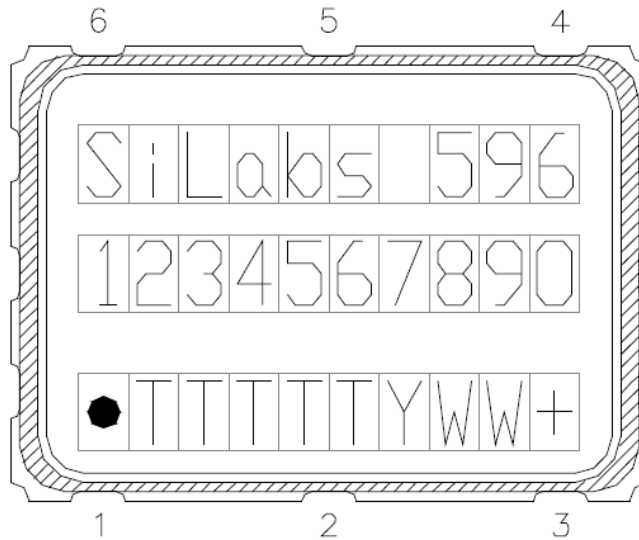

Figure 6. Mark Specification
Table 16. Si596 Top Mark Description

Line	Position	Description
1	1–10	“SiLabs”+ Part Family Number, 596 (First 3 characters in part number)
2	1–10	Si596: Option1+Option2+Freq(6)+Temp
3	Trace Code	
	Position 1	Pin 1 orientation mark (dot)
	Position 2	Product Revision (D)
	Position 3–6	Tiny Trace Code (4 alphanumeric characters per assembly release instructions)
	Position 7	Year (least significant year digit), to be assigned by assembly site (ex: 2009 = 9)
	Position 8–9	Calendar Work Week number (1–53), to be assigned by assembly site
	Position 10	“+” to indicate Pb-Free and RoHS-compliant

9. Si596 Top Marking: 3.2x5 mm

Figure 7 illustrates the mark specification for the 3.2x5 mm Si596. Table 17 lists the line information.

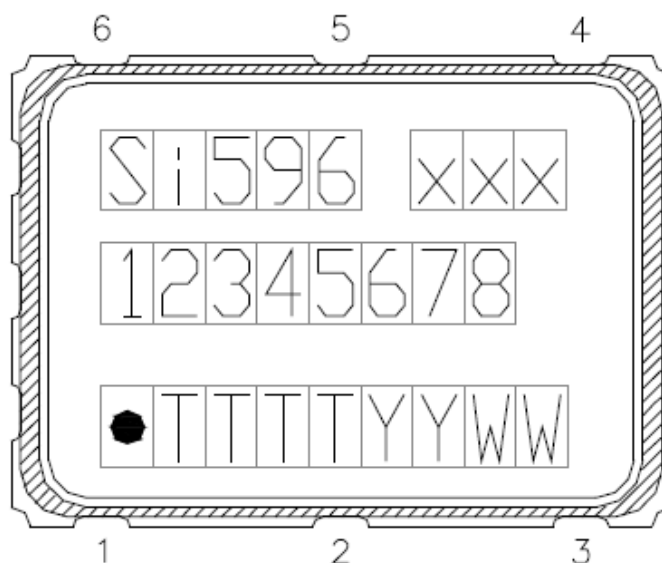

Figure 7. Mark Specification

Table 17. Si596 Top Mark Description

Line	Position	Description
1	1–5	“Si”+ Part Family Number, 596 (First 3 characters in part number)
	6-8	Crystal trace code (3 alphanumeric characters assigned by assembly site)
2	1–8	Si596: Option1+Option2+Freq(6)
3	Trace Code	
	Position 1	Pin 1 orientation mark (dot)
	Position 2	Product Revision (D)
	Position 3–5	Tiny Trace Code (3 alphanumeric characters per assembly release instructions)
	Position 6-7	Year (last two digits of year), to be assigned by assembly site (ex: 2017 = 17)
	Position 8–9	Calendar Work Week number (1–53), to be assigned by assembly site

REVISION HISTORY

Revision 1.2

June, 2018

- Changed “Trays” to “Coil Tape” in 3. "Ordering Information" on page 9.

Revision 1.1

December, 2017

- Added 3.2 x 5 mm package.

Revision 1.0

June, 2016

- Initial release.



ClockBuilder Pro

One-click access to Timing tools, documentation, software, source code libraries & more. Available for Windows and iOS (CBGo only).

www.silabs.com/CBPro



Timing Portfolio
www.silabs.com/timing



SW/HW
www.silabs.com/CBPro



Quality
www.silabs.com/quality



Support and Community
community.silabs.com

Disclaimer

Silicon Labs intends to provide customers with the latest, accurate, and in-depth documentation of all peripherals and modules available for system and software implementers using or intending to use the Silicon Labs products. Characterization data, available modules and peripherals, memory sizes and memory addresses refer to each specific device, and "Typical" parameters provided can and do vary in different applications. Application examples described herein are for illustrative purposes only. Silicon Labs reserves the right to make changes without further notice and limitation to product information, specifications, and descriptions herein, and does not give warranties as to the accuracy or completeness of the included information. Silicon Labs shall have no liability for the consequences of use of the information supplied herein. This document does not imply or express copyright licenses granted hereunder to design or fabricate any integrated circuits. The products are not designed or authorized to be used within any Life Support System without the specific written consent of Silicon Labs. A "Life Support System" is any product or system intended to support or sustain life and/or health, which, if it fails, can be reasonably expected to result in significant personal injury or death. Silicon Labs products are not designed or authorized for military applications. Silicon Labs products shall under no circumstances be used in weapons of mass destruction including (but not limited to) nuclear, biological or chemical weapons, or missiles capable of delivering such weapons.

Trademark Information

Silicon Laboratories Inc.®, Silicon Laboratories®, Silicon Labs®, SiLabs® and the Silicon Labs logo®, Bluegiga®, Bluegiga Logo®, Clockbuilder®, CMEMS®, DSPLL®, EFM®, EFM32®, EFR, Ember®, Energy Micro, Energy Micro logo and combinations thereof, "the world's most energy friendly microcontrollers", Ember®, EZLink®, EZRadio®, EZRadioPRO®, Gecko®, ISOModem®, Micrium, Precision32®, ProSLIC®, Simplicity Studio®, SiPHY®, Telegesis, the Telegesis Logo®, USBXpress®, Zentri, Z-Wave, and others are trademarks or registered trademarks of Silicon Labs. ARM, CORTEX, Cortex-M3 and THUMB are trademarks or registered trademarks of ARM Holdings. Keil is a registered trademark of ARM Limited. All other products or brand names mentioned herein are trademarks of their respective holders.



Silicon Laboratories Inc.
400 West Cesar Chavez
Austin, TX 78701
USA

<http://www.silabs.com>