



Chipsmall Limited consists of a professional team with an average of over 10 year of expertise in the distribution of electronic components. Based in Hongkong, we have already established firm and mutual-benefit business relationships with customers from,Europe,America and south Asia,supplying obsolete and hard-to-find components to meet their specific needs.

With the principle of "Quality Parts,Customers Priority,Honest Operation,and Considerate Service",our business mainly focus on the distribution of electronic components. Line cards we deal with include Microchip,ALPS,ROHM,Xilinx,Pulse,ON,Everlight and Freescale. Main products comprise IC,Modules,Potentiometer,IC Socket,Relay,Connector.Our parts cover such applications as commercial,industrial, and automotives areas.

We are looking forward to setting up business relationship with you and hope to provide you with the best service and solution. Let us make a better world for our industry!



Contact us

Tel: +86-755-8981 8866 Fax: +86-755-8427 6832

Email & Skype: info@chipsmall.com Web: www.chipsmall.com

Address: A1208, Overseas Decoration Building, #122 Zhenhua RD., Futian, Shenzhen, China



REV	ECN NO	REVISIONS	DRN	CKD	APP	DATE
A		NEW RELEASE	TWC	TC	N.O.	9-22-05
B		UPDATED LED SPECS, ADDED RoHS COMPLIANT NOTE, ADDED ESD NOTE AND SYMBOL.	KLJ	NO	MES	2-15-08
C		UPDATE LED INT (3.55 & 42) WAS (2.24 & 37) FOR 5972301213F, 202F	JTD	NO	MES	2-29-12

NOTES:

- COLORLESS CLEAR WINDOW.
- LED CHIP: InGaAlP
- LED LEAD FINISH: PURE MATT TIN (Sn) $8.0 \pm 2.0 \mu\text{m}$ WITH NICKEL (Ni) UNDERLAYER OVER COPPER (Cu).
- DIALIGHT PART NUMBERS: 597-2001-202F, -213F
597-2301-202F, -213F
597-2401-202F, -213F.
- PACKAGING:
-202F SUFFIX INDICATES 20 PCS SAMPLE STRIP
-213F SUFFIX INDICATES 2000 PARTS/REEL ON 13" [330 mm] DIA. REEL
- REEL AND PACKAGING HAS A LABEL WITH DIALIGHT LOGO, DIALIGHT P/N, QTY PER REEL, DATE CODE, LOT NUMBER, INTENSITY BIN CODE, COLOR BIN CODE, AND COUNTRY OF ORIGIN.
- THIS ASSEMBLY CONTAINS ELECTROSTATIC DISCHARGE SENSITIVE DEVICES (ESDS). MAINTAIN ALL PRECAUTIONARY MEASURES DURING ASSEMBLY, HANDLING, AND STORAGE IN ACCORDANCE WITH IPC-A-610.

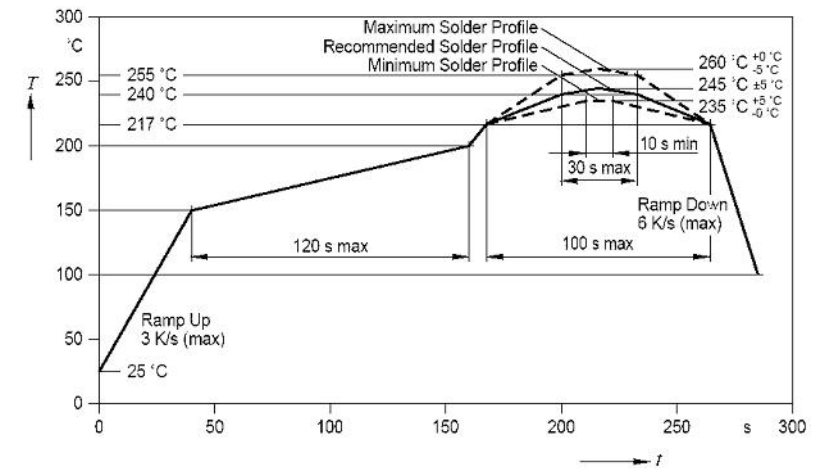
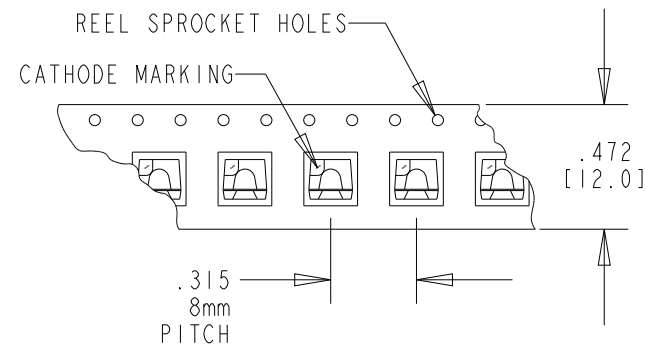
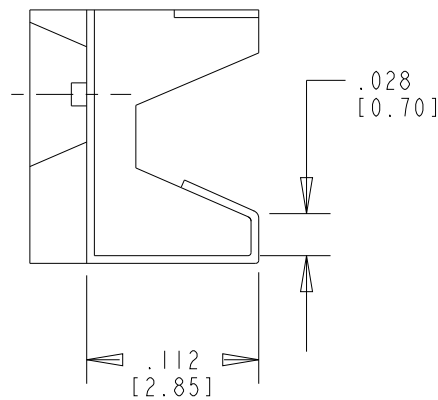
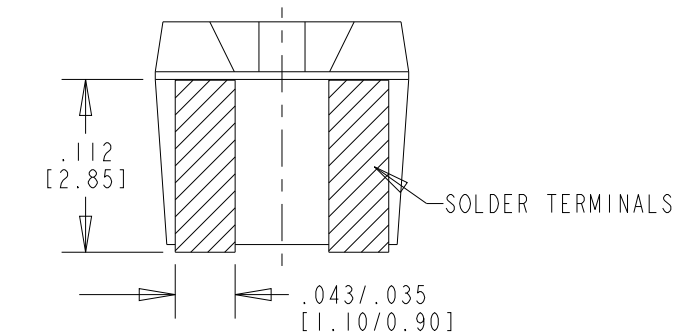
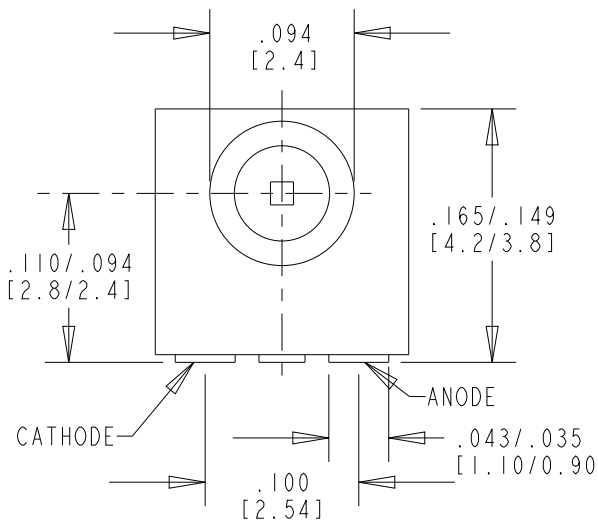
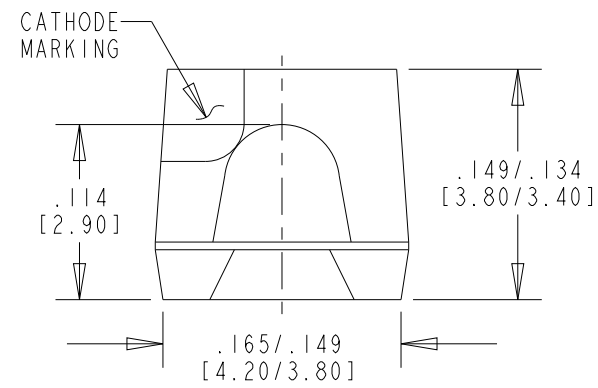

BI-COLOR OPERATING CHARACTERISTICS AT T _a = 25 °C AMBIENT															
DIALIGHT P/N	COLOR	FORWARD VOLTAGE (V) @ I _F = 10 mA			LUMINOUS INTENSITY (mcd) @ I _F = 2 mA			LUMINOUS INTENSITY (mcd) @ I _F = 10 mA			PEAK WAVELENGTH (nm)	DOMINANT WAVELENGTH (nm)			VIEWING ANGLE (2 θ 1/2)
		MIN.	TYP.	MAX.	MIN.	TYP.	MAX.	MIN.	TYP.	MAX.	TYP.	MIN.	TYP.	MAX.	
597-2001-213F, -202F	RED	1.7	1.8	2.2	4.5	7.8	11.2	20	40	60	643	624	630	636	120
597-2301-213F, -202F	GREEN	1.7	1.8	2.2	3.55	5.6	9.0	10	42	50	572	566	570	575	120
597-2401-213F, -202F	YELLOW	1.7	1.8	2.2	5.6	14.0	22.4	25	70	115	591	580	587	595	120

ABSOLUTE MAXIMUM RATINGS AT 25°C AMBIENT	UNITS	RED	GREEN	YELLOW
POWER DISSIPATION	mW	45	40	45
CONTINUOUS FORWARD CURRENT	mA	20		
PEAK FORWARD CURRENT t _p < 10 μS, D=.005	mA	100		
REVERSE VOLTAGE @ 10 μA	V	12		
SOLDERING TEMPERATURE, 10 SEC.	°C	260		
OPERATING TEMPERATURE	°C	-40 TO +100		
STORAGE TEMPERATURE	°C	-40 TO +100		



ATTENTION:
OBSERVE PRECAUTIONS FOR HANDLING ELECTROSTATIC SENSITIVE DEVICES

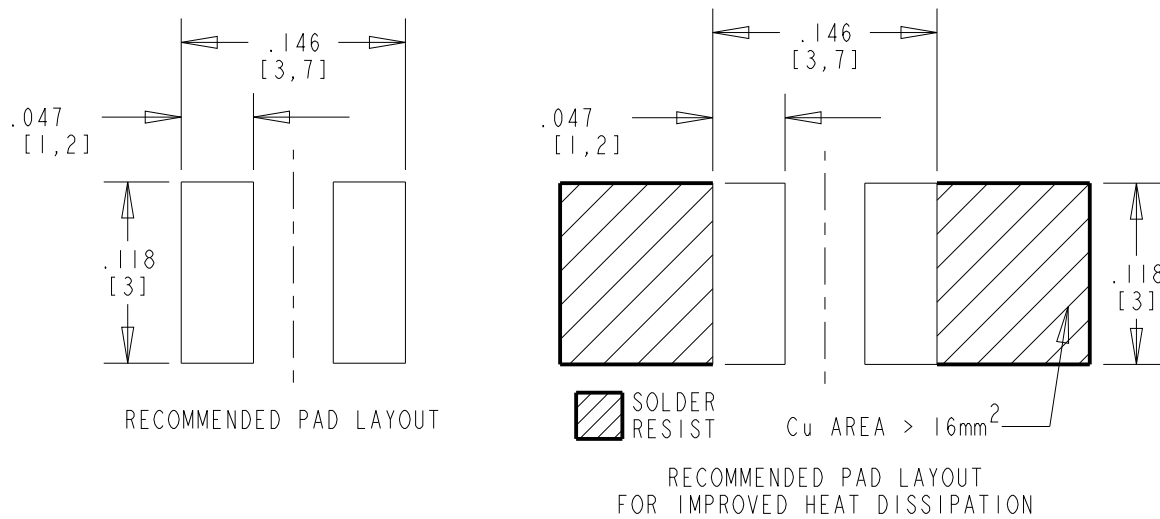

RoHS COMPLIANT 597-2X01-2XXF

Part Numbers with the "F" suffix ending are RoHS Compliant. For example: 597-2401-207F
Reel and bag packaging are marked with "RoHS Compliant" label or equivalent markings. These parts can be used with RoHS reflow profile. Parts can be wave soldered, dip soldered or hand soldered using typical lead-free soldering process with max 260°C temp. for 10 sec.

THIS DRAWING AND THE CONTENTS HEREIN ARE CONFIDENTIAL AND THE SOLE PROPERTY OF DIALIGHT. REPRODUCTION OF THIS DRAWING OR CONSTRUCTION OF ANY PARTS WITHIN THIS DRAWING ARE FORBIDDEN WITHOUT THE WRITTEN CONSENT OF DIALIGHT.

SCALE: DRAWING SCALE ALL DIM'S IN: INCHES (MM)	DRAWING NUMBER C-17300	REV C
TOLERANCES: UNLESS OTHERWISE SPECIFIED FRACTIONS: ±1/64 DECIMALS (.XX): ±.01 DECIMALS (.XXX): ±.005 DECIMALS (.XXXX): ±.0005 ANGLES: ±1°	TITLE SMT-SIDELED RoHS COMPLIANT	MATERIAL
FINISH:	1501 ROUTE 34 SOUTH FARMINGDALE, NJ 07727	
FSCM 83330	SHEET 1 OF 1	FAMILY TABLE: