



Chipsmall Limited consists of a professional team with an average of over 10 year of expertise in the distribution of electronic components. Based in Hongkong, we have already established firm and mutual-benefit business relationships with customers from,Europe,America and south Asia,supplying obsolete and hard-to-find components to meet their specific needs.

With the principle of “Quality Parts,Customers Priority,Honest Operation,and Considerate Service”,our business mainly focus on the distribution of electronic components. Line cards we deal with include Microchip,ALPS,ROHM,Xilinx,Pulse,ON,Everlight and Freescale. Main products comprise IC,Modules,Potentiometer,IC Socket,Relay,Connector.Our parts cover such applications as commercial,industrial, and automotives areas.

We are looking forward to setting up business relationship with you and hope to provide you with the best service and solution. Let us make a better world for our industry!



Contact us

Tel: +86-755-8981 8866 Fax: +86-755-8427 6832

Email & Skype: info@chipsmall.com Web: www.chipsmall.com

Address: A1208, Overseas Decoration Building, #122 Zhenhua RD., Futian, Shenzhen, China



OPERATING CHARACTERISTICS AT 25°C AMBIENT

COLOR	LUMINOUS INTENSITY @ I _F = 20 mA (mcd)			FORWARD VOLTAGE @ I _F = 20 mA (V)		REVERSE CURRENT (μA)	DOMINANT WAVELENGTH (nm)			PEAK WAVELENGTH (nm)	VIEWING ANGLE (DEG)
	MIN	TYP	MAX	TYP	MAX	MAX	MIN	TYP	MAX	TYP	TYP
	RED	28	55	112	2.0	2.4	10	—	631	—	639
GREEN	28	45	112	2.0	2.4	10	567	571	577	574	



ATTENTION:
OBSERVE PRECAUTIONS FOR
HANDLING ELECTROSTATIC
SENSITIVE DEVICES

RoHS COMPLIANT 597-7703-60XF

Part Numbers with the "F" suffix ending are RoHS Compliant. Reel and bag packaging are marked with "RoHS Compliant" label or equivalent markings. These parts can be used with RoHS reflow profile. Parts can be wave soldered, dip soldered or hand soldered using typical lead-free soldering process with max 260°C temp. for 5 sec.

ABSOLUTE MAXIMUM RATINGS AT 25°C AMBIENT	COLOR		UNITS
	RED	GREEN	
POWER DISSIPATION	75	75	mW
DC FORWARD CURRENT	30	30	mA
PEAK FORWARD CURRENT (1/10 DUTY CYCLE, 0.1ms PULSE)	80	80	mA
DERATE LINEARLY FROM 25°C	0.42	0.42	mA/°C
REVERSE VOLTAGE	5		V
STORAGE TEMPERATURE	-40 TO +85°C		°C
OPERATING TEMPERATURE	-30 TO +85°C		°C
IR SOLDERING TEMPERATURE, FOR 10 SEC	260		°C

REV	ECN NO	REVISIONS	DRN	CKD	APP	DATE
A	—	NEW RELEASE	KLJ	JLC	N.O.	6-30-09
B	—	ADDED PCB LAYOUT	AJF	KLJ	NO	7-24-09

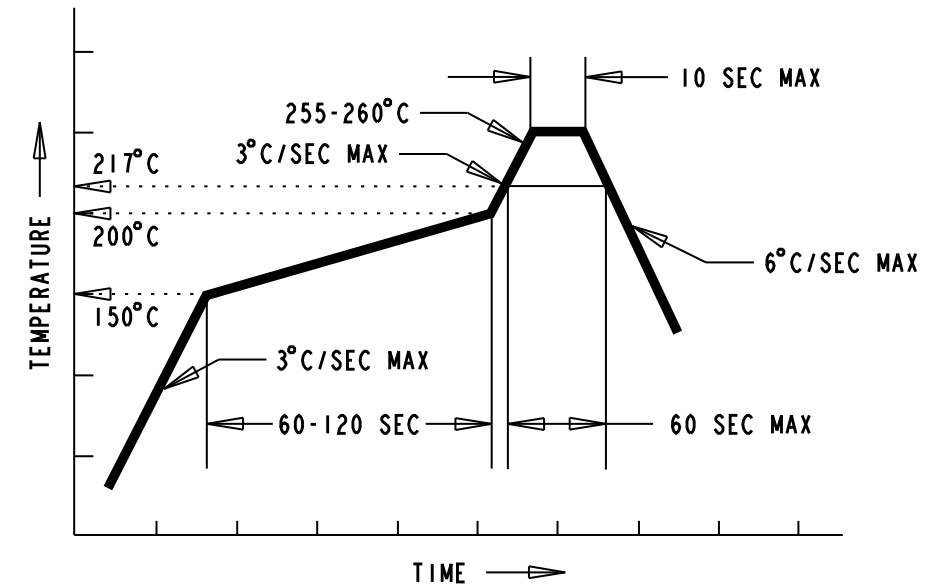

RECOMMENDED RoHS SOLDER PROFILE

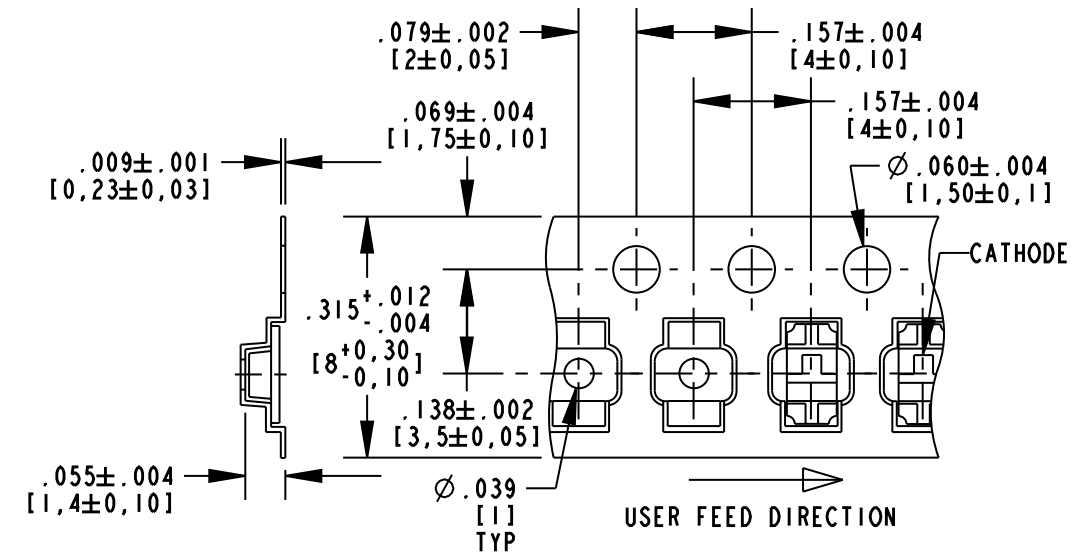
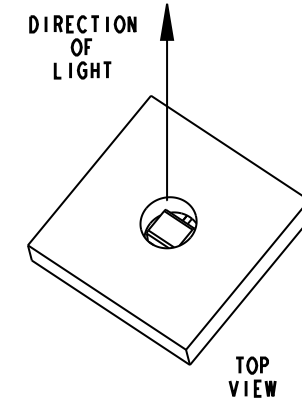
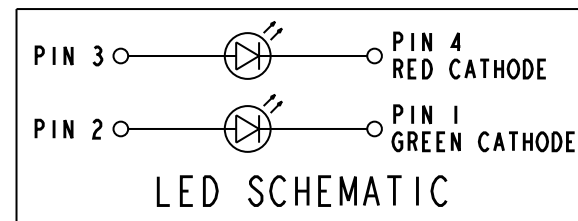
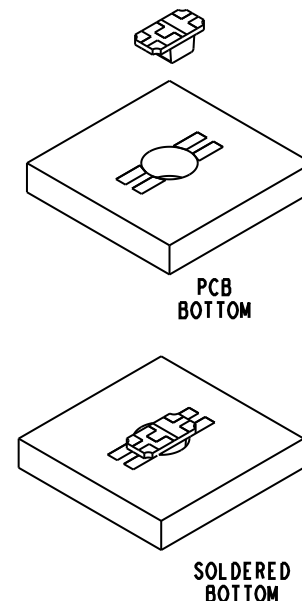
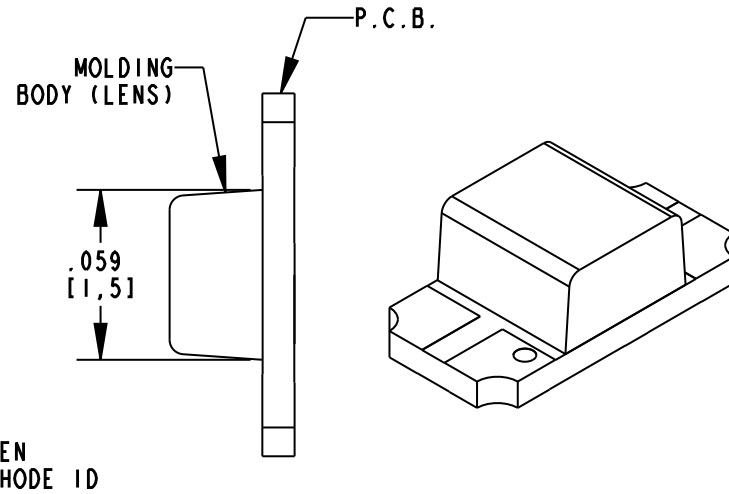
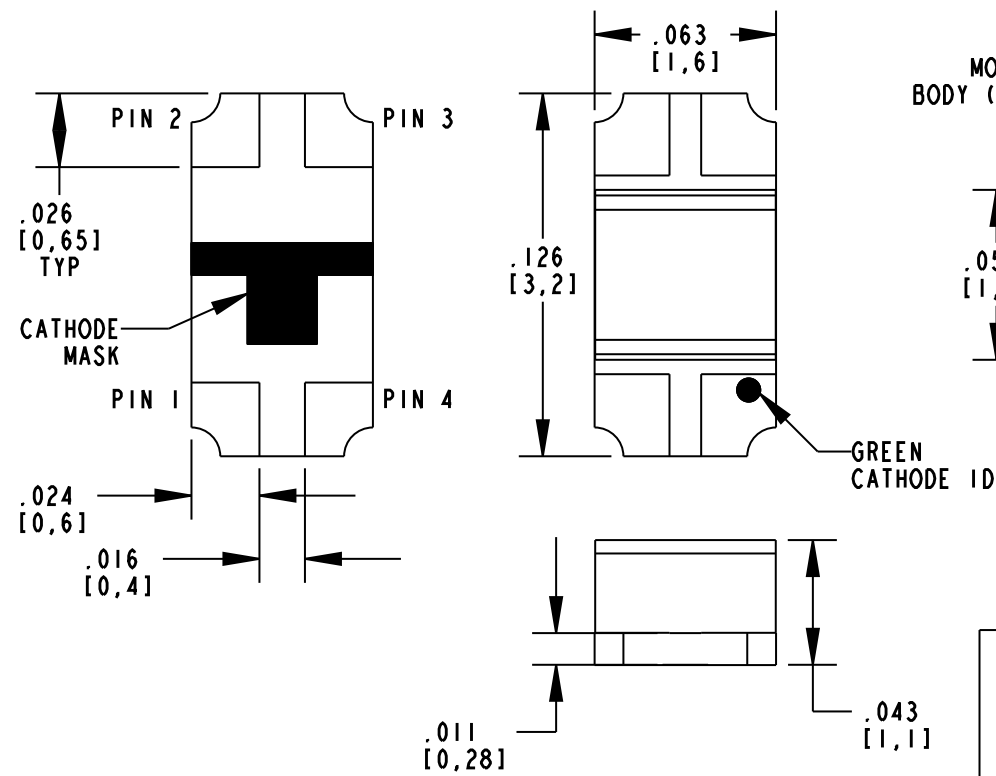

PACKAGE DIMENSIONS OF TAPE AND REEL

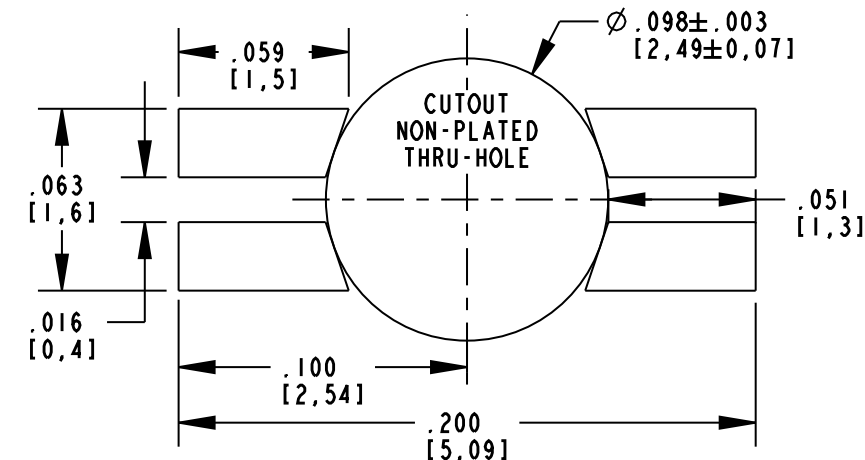

RECOMMENDED SOLDER PAD LAYOUT

NOTES:

- LENS: WATER CLEAR
- LED CHIP: AlInGaP RED & GREEN
- LEADS ARE GOLD (Au) PLATED FINISH.
- PACKAGING: -602F SUFFIX MEANS 20 PCS SAMPLE STRIP
-607F SUFFIX MEANS 3000 PARTS/REEL, Ø7 INCH REEL
- MOISTURE SENSITIVITY LEVEL 3.
- TAPE AND REEL LEDS MAY REQUIRE RE-TAPING AFTER TWELVE MONTHS.
- DIALIGHT PART NUMBERS: 597-7703-602F, 597-7703-607F
- THIS ASSEMBLY CONTAINS ELECTROSTATIC DISCHARGE SENSITIVE DEVICES (ESDS). MAINTAIN ALL PRECAUTIONARY MEASURES DURING ASSEMBLY, HANDLING, AND STORAGE IN ACCORDANCE WITH IPC-A-610.

THIS DRAWING AND THE CONTENTS HEREIN ARE CONFIDENTIAL AND THE SOLE PROPERTY OF DIALIGHT. REPRODUCTION OF THIS DRAWING OR CONSTRUCTION OF ANY PARTS WITHIN THIS DRAWING ARE FORBIDDEN WITHOUT THE WRITTEN CONSENT OF DIALIGHT.

SCALE: 15.000	DRAWING NUMBER	REV
ALL DIM'S IN: INCHES (MM)	C-17741	B
TOLERANCES: UNLESS OTHERWISE SPECIFIED	TITLE 3.2mm x 1.6mm x 1.1mm REVERSE MOUNT LED; RoHS COMPLIANT	
FRACTIONS: ±1/64	MATERIAL	
DECIMALS (.XX): ±.01	-	
DECIMALS (.XXX): ±.005	-	
ANGLES: ±3°	-	
FINISH:	-	
FSCM 83330	Dialight 1501 ROUTE 34 SOUTH FARMINGDALE, NJ 07727	
SHEET 1 OF 1		FAMILY TABLE: