



Chipsmall Limited consists of a professional team with an average of over 10 year of expertise in the distribution of electronic components. Based in Hongkong, we have already established firm and mutual-benefit business relationships with customers from,Europe,America and south Asia,supplying obsolete and hard-to-find components to meet their specific needs.

With the principle of “Quality Parts,Customers Priority,Honest Operation,and Considerate Service”,our business mainly focus on the distribution of electronic components. Line cards we deal with include Microchip,ALPS,ROHM,Xilinx,Pulse,ON,Everlight and Freescale. Main products comprise IC,Modules,Potentiometer,IC Socket,Relay,Connector.Our parts cover such applications as commercial,industrial, and automotives areas.

We are looking forward to setting up business relationship with you and hope to provide you with the best service and solution. Let us make a better world for our industry!



Contact us

Tel: +86-755-8981 8866 Fax: +86-755-8427 6832

Email & Skype: info@chipsmall.com Web: www.chipsmall.com

Address: A1208, Overseas Decoration Building, #122 Zhenhua RD., Futian, Shenzhen, China





EEPROM PROGRAMMABLE CLOCK GENERATOR

IDT5V49EE902

Description

The IDT5V49EE902 is a programmable clock generator intended for high performance data-communications, telecommunications, consumer, and networking applications. There are four internal PLLs, each individually programmable, allowing for four unique non-integer-related frequencies. The frequencies are generated from a single reference clock. The reference clock can come from one of the two redundant clock inputs. Automatic or manual switchover function allows any one of the redundant clocks to be selected during normal operation.

The IDT5V49EE902 is in-system, programmable and can be programmed through the use of I²C interface. An internal EEPROM allows the user to save and restore the configuration of the device without having to reprogram it on power-up.

Each of the four PLLs has an 7-bit reference divider and a 12-bit feedback divider. This allows the user to generate four unique non-integer-related frequencies. The PLL loop bandwidth is programmable to allow the user to tailor the PLL response to the application. For instance, the user can tune the PLL parameters to minimize jitter generation or to maximize jitter attenuation. Spread spectrum generation and/or fractional divides are allowed on two of the PLLs.

There are a total of six 8-bit output dividers. Each output bank can be configured to support LVTTTL, LVPECL, LVDS or HCSL logic levels. Out0 (Output 0) supports 3.3V single-ended output only. The outputs are connected to the PLLs via a switch matrix. The switch matrix allows the user to route the PLL outputs to any output bank. This feature can be used to simplify and optimize the board layout. In addition, each output's slew rate and enable/disable function is programmable.

Features

- Four internal PLLs
- Internal non-volatile EEPROM
- Fast (400kHz) mode I²C serial interface
- Input frequency range: 1 MHz to 200 MHz
- Output frequency range: 4.9 kHz to 500 MHz
- Reference crystal input with programmable linear load capacitance
 - Crystal frequency range: 8 MHz to 50 MHz
- Four independently controlled VDDO (1.8V - 3.3V)
- Each PLL has a 7-bit reference divider and a 12-bit feedback-divider
- 8-bit output-divider blocks
- Fractional division capability on one PLL
- Two of the PLLs support spread spectrum generation capability
- I/O Standards:
 - Outputs - 1.8 - 3.3 V LVTTTL/ LVCMOS
 - Outputs - LVPECL, LVDS and HCSL
 - Inputs - 3.3 V LVTTTL/ LVCMOS
- Programmable slew rate control
- Programmable loop bandwidth
- Programmable output inversion to reduce bimodal jitter
- Redundant clock inputs with auto and manual switchover options
- Individual output enable/disable
- Power-down mode
- 3.3V core V_{DD}
- Available in VFQFPN package
- -40 to +85 C Industrial Temp operation

Functional Block Diagram

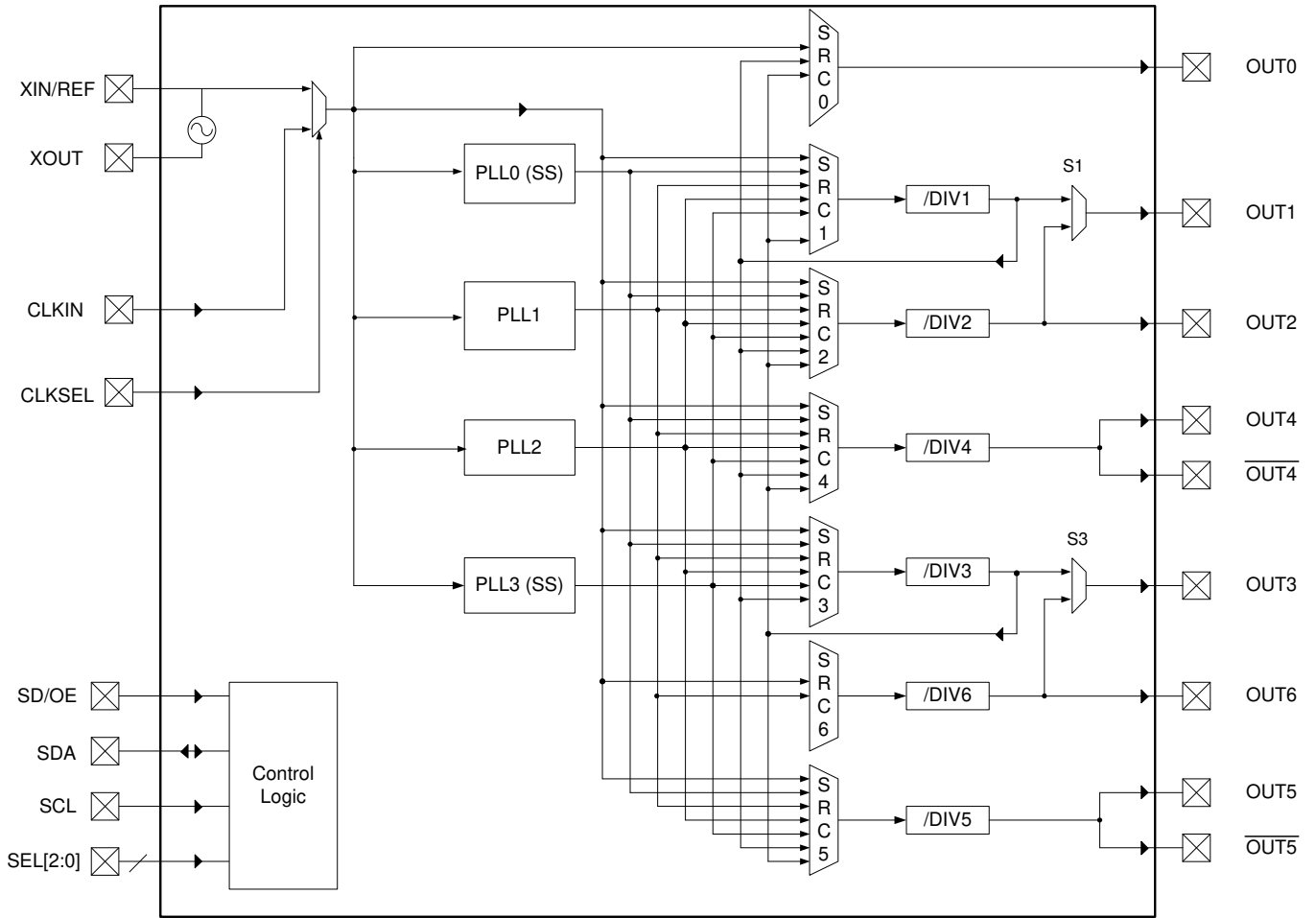

1. OUT1 & OUT2, OUT4 & $\overline{\text{OUT4}}$, OUT3 & OUT6, and OUT5 & $\overline{\text{OUT5}}$ pairs can be configured to be LVDS, LVPECL or HCSSL, or two single-ended LVTTTL outputs.
2. CLKIN, CLKSEL, SD/OE and SEL[2:0] have pull down resistors.

PIN CONFIGURATION

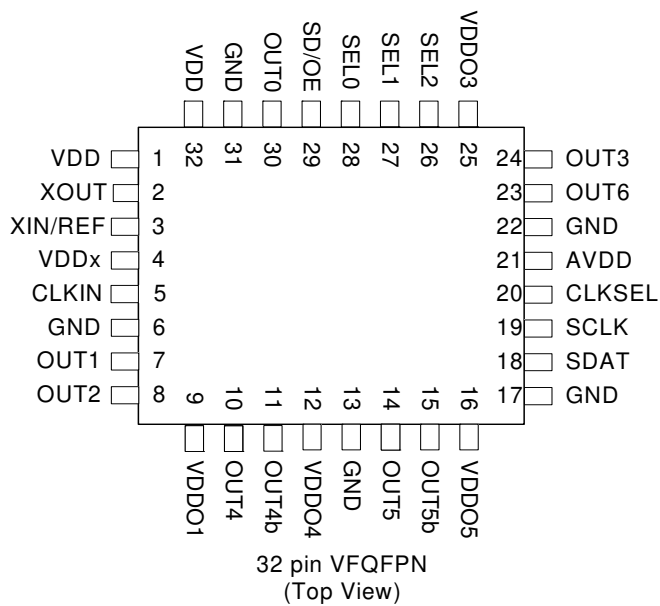

Pin Descriptions

Pin Name	NL32 Pin#	I/O	Pin Type	Pin Description
CLKIN	5	I	LVTTL	Input clock. Weak internal pull down resistor.
XOUT	2	O	LVTTL	CRYSTAL_OUT -- Reference crystal feedback.
XIN / REF	3	I	LVTTL	CRYSTAL_IN -- Reference crystal input or external reference clock input.
SDAT	18	I/O	Open Drain	Bidirectional I ² C data. An external pull-up resistor is required. See I ² C specification for pull-up value recommendation.
SCLK	19	I	LVTTL	I ² C clock. An external pull-up resistor is required. See I ² C specification for pull-up value recommendation.
CLKSEL	20	I	LVTTL	Input clock selector. Weak internal pull down resistor.
SEL2	26	I	LVTTL	Configuration select pin. Weak internal pull down resistor.
SEL1	27	I	LVTTL	Configuration select pin. Weak internal pull down resistor.
SEL0	28	I	LVTTL	Configuration select pin. Weak internal pull down resistor.
SD/OE	29	I	LVTTL	Enables/disables the outputs or powers down the chip. The SP bit (0x02) controls the polarity of the signal to be either active HIGH or LOW. (Default is active LOW.) Weak internal pull down resistor.
OUT0	30	O	LVTTL	Configurable clock output 0. 3.3V LVTTL levels.

Pin Name	NL32 Pin#	I/O	Pin Type	Pin Description
OUT1	7	O	Adjustable ¹	Configurable clock output 1. Single-ended or differential when combined with OUT2. Output levels controlled by VDDO1.
OUT2	8	O	Adjustable ¹	Configurable clock output 2. Single-ended or differential when combined with OUT1. Output levels controlled by VDDO1.
OUT3	24	O	Adjustable ¹	Configurable clock output 3. Single-ended or differential when combined with OUT6. Output levels controlled by VDDO3.
OUT4	10	O	Adjustable ^{1,2}	Configurable clock output 4. Single-ended or differential when combined with OUT4b. Output levels controlled by VDDO4.
OUT4b	11	O	Adjustable ^{1,2}	Configurable clock output 4b. Single-ended or differential when combined with OUT4. Output levels controlled by VDDO4.
OUT5	14	O	Adjustable ^{1,2}	Configurable clock output 5. Single-ended or differential when combined with OUT5b. Output levels controlled by VDDO5.
OUT5b	15	O	Adjustable ^{1,2}	Configurable clock output 5b. Single-ended or differential when combined with OUT5. Output levels controlled by VDDO5.
OUT6	23	O	Adjustable ¹	Configurable clock output 6. Single-ended or differential when combined with OUT3. Output levels controlled by VDDO3.
VDD	1,4, 21, 32		Power	Device power supply. Connect to 3.3V.
VDDx	4		Power	Crystal oscillator power supply. Connect to 3.3V through 5Ω resistor. Use filtered analog power supply if available.
AVDD	21		Power	Device analog power supply. Connect to 3.3V. Use filtered analog power supply if available.
VDDO1	9		Power	Device power supply. Connect to 1.8 to 3.3V. Sets output voltage levels for OUT1 and OUT2.
VDDO3	25		Power	Device power supply. Connect to 1.8 to 3.3V. Sets output voltage levels for OUT3 and OUT6.
VDDO4	12		Power	Device power supply. Connect to 1.8 to 3.3V. Sets output voltage levels for OUT4 and OUT4b.
VDDO5	16		Power	Device power supply. Connect to 1.8 to 3.3V. Sets output voltage levels for OUT5 and OUT5b.
GND	6, 13, 17, 22, 31, PAD		Power	Connect to Ground.

1. Outputs are user programmable to drive single-ended 3.3-V LVTTTL, or differential LVDS, LVPECL or HCSL interface levels

2. When only an individual single-ended clock output is required, tie OUT# and OUT#b together.

3. Analog power plane should be isolated from a 3.3V power plane through a ferrite bead.

4. Each power pin should have a dedicated 0.01μF de-coupling capacitor. Digital VDDs may be tied together.

5. Unused clock inputs (REFIN or CLKIN) must be pulled high or low - they cannot be left floating. If the crystal oscillator is not used, XOUT must be left floating.

PLL Features and Descriptions

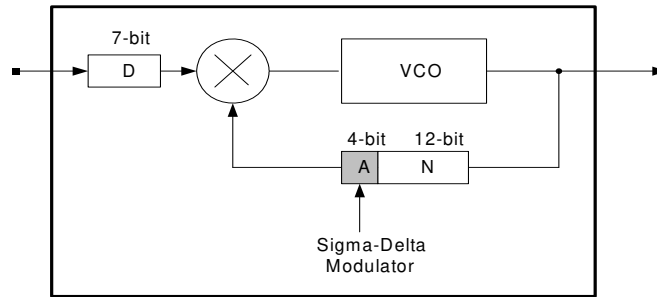

PLL0 Block Diagram

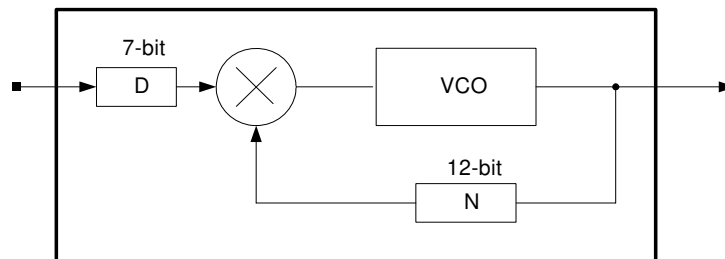

PLL1, PLL2 and PLL3 Block Diagram

	Pre-Divider (D) ¹ Values	Multiplier (M) ² Values	Programmable Loop Bandwidth	Spread Spectrum Generation Capability
PLL0	1 - 127	10 - 8206	Yes	Yes
PLL1	1 - 127	1 - 4095	Yes	No
PLL2	1 - 127	1 - 4095	Yes	No
PLL3	3 - 127	12 - 4095	Yes	Yes

1. For PLL0, PLL1 and PLL2, D=0 means PLL power down. For PLL3, 0, 1, and 2 are DNU (do not use)
 2. For PLL0, $M = 2^*N + A + 1$ (for $A > 0$); $M = 2^*N$ (for $A = 0$); $A \leq N-1$. For PLL1, PLL2 and PLL3, $M=N$.

Reference Clock Input Pins and Selection

The IDT5V49EE902 supports up to two clock inputs. One of the clock inputs (XIN/ REF) can be driven by either an external crystal or a reference clock. The second clock input (CLKIN) can only be driven from an external reference clock. The CLKSEL pin selects the input clock from either XTAL/REF or CLKIN.

Either clock input can be set as the primary clock. The primary clock designation is to establish which is the main reference clock to the PLLs. The non-primary clock is designated as the secondary clock in case the primary clock goes absent and a backup is needed. The PRIMSRC bit (0xBE through 0xC3) determines which clock input will be selected as primary clock. When PRIMSRC bit is "0", XIN/REF is selected as the primary clock, and when "1", CLKIN as the primary clock.

The two external reference clocks can be manually selected using the CLKSEL pin. The SM bits (0xBE through 0xC3) must be set to "0x" for manual switchover which is detailed in SWITCHOVER MODES section.

Crystal Input (XIN/REF)

The crystal used should be a fundamental mode quartz crystal; overtone crystals should not be used.

When the XIN/REF pin is driven by a crystal, it is important to set the internal inverter oscillator drive strength and tuning/load capacitor values correctly to achieve the best clock performance. These values are programmable through I²C interface to allow for maximum compatibility with crystals from various manufacturers, processes, performances, and qualities. The internal load capacitors are true parallel-plate capacitors for ultra-linear performance. Parallel-plate capacitors were chosen to reduce the frequency shift that occurs when non-linear load capacitance interacts with load, bias, supply, and temperature changes. External non-linear crystal load capacitors should not be used for applications that are sensitive to absolute frequency requirements. The value of the internal load capacitors are determined by XTAL[4:0] bits. The load capacitance can be set with a resolution of 0.125 pF for a total crystal load ranging from 3.5 pF to 7.5 pF. Check with the crystal vendor's load capacitance specification for the exact setting to tune the internal load capacitor. The following equation governs how the total

internal load capacitance is set.

$$\text{XTAL load cap} = 3.5 \text{ pF} + \text{XTAL}[4:0] * 0.125 \text{ pF (Eq. 1)}$$

Parameter	Bits	Step (pF)	Min (pF)	Max (pF)
XTAL	8	0.125	0	4

When using an external reference clock instead of a crystal on the XTAL/REF pin, the input load capacitors may be completely bypassed. This allows for the input frequency to be up to 200 MHz. When using an external reference clock, the XOUT pin must be left floating, XTAL must be programmed to the default value of "00h", and the crystal drive strength bit, XDRV (0x06), must be set to the default value of "11h".

Switchover Modes

The IDT5V49EE902 features redundant clock inputs which supports both Automatic and Manual switchover mode. These two modes are determined by the configuration bits, SM (0xBE through 0xC3). The primary clock source can be programmed, via the PRIMSRC bit, to be either XIN/REF or CLKIN. The other clock input will be considered as the secondary source. Note that the switchover modes are asynchronous. If the reference clocks are directly routed to OUTx with no phase relationship, short pulses can be generated during switchover. The automatic switchover mode will work only when the primary clock source is XIN/REF. Switchover modes are not supported for crystal input configurations.

Manual Switchover Mode

When SM[1:0] is "0x", the redundant inputs are in manual switchover mode. In this mode, CLKSEL pin is used to switch between the primary and secondary clock sources. As previously mentioned, the primary and secondary clock source setting is determined by the PRIMSRC bit. During the switchover, no glitches will occur at the output of the device, although there may be frequency and phase drift, depending on the exact phase and frequency relationship between the primary and secondary clocks.

Automatic Switchover Mode

The redundant inputs are in automatic switchover mode. Automatic switchover mode has revertive functionality. The input clock selection will switch to the secondary clock source when there are no transitions on the primary clock source for two secondary clock cycles. If both reference

clocks are at different frequencies, the device will always remain on the primary clock unless it is absent for two secondary clock cycles. The secondary clock must always run at a frequency less than or equal to the primary clock frequency.

Reference Divider, Feedback Divider, and Output Divider

Each PLL incorporates a 7-bit reference divider (D[6:0]) and a 12-bit feedback divider (N[11:0]) that allows the user to generate four unique non-integer-related frequencies. Each output divide supports 8-bit output-divider (PM and Q[7:0]). The following equation governs how the output frequency is calculated.

$$F_{OUT} = \frac{F_{IN} * \left(\frac{M}{D}\right)}{ODIV} \quad (\text{Eq. 1})$$

Where FIN is the reference frequency, M is the total feedback-divider value, D is the reference divider value, ODIV is the total output-divider value, and FOUT is the resulting output frequency.

For PLL0,

$$M = 2 * N + A + 1 \quad (\text{for } A > 0)$$

$$M = 2 * N \quad (\text{for } A = 0)$$

For PLL1, PLL2 and PLL3,

$$M = N$$

PM and Q[6:0] are the bits used to program the 8-bit output-dividers for outputs OUT1-6. OUT0 does not have any output divide along its path. The 8-bit output-dividers will bypass or divide down the output banks' frequency with even integer values ranging from 2 to 256.

There is the option to choose between disabling the output-divider, utilizing a div/1, a div/2, or the 7-bit Q-divider by using the PM bit. If the output is disabled, it will be driven High, Low or High Impedance, depending on OEM[1:0]. Each bank, except for OUT0, has a PM bit. When disabled, no clocks will appear at the output of the divider, but will remain powered on. The output divides selection table is shown below.

Q[6:0]	PM	Output Divider
111 1111	0	Disabled
	1	/1
<111 1111	0	/2
	1	/((Q[6:0] + 2) * 2)

Note that the actual 7-bit Q-divider value has a 2 added to the integer value Q and the outputs are routed through another div/2 block. The output divider should never be disabled unless the output bank will never be used during normal operation. The output frequency range for LVTTTL outputs are from 4.9KHz to 200MHz. The output frequency for LVPECL/LVDS/HCSL outputs range from 4.9KHz to 500MHz.

Spread Spectrum Generation (PLL0)

PLL0 supports spread spectrum generation capability, which users have the option of turning on or off. Spread spectrum profile, frequency, and spread amplitude are fully programmable. The programmable spread spectrum generation parameters are TSSC[3:0], NSSC[2:0], SS_OFFSET[5:0], SD[3:0], DITH, and X2 bits. These bits are in the memory address from 0xAC to 0xBD for PLL0. The spread spectrum generation on PLL0 can be enabled/disabled using the TSSC[3:0] bits. To enable spread spectrum, set TSSC > '0' and set NSSC[2:0], SS_OFFSET[5:0], SD[3:0], and the A[3:0] (in the total M value) accordingly. To disable spread spectrum generation, set TSSC = '0'.

TSSC[3:0]

These bits are used to determine the number of phase/frequency detector cycles per spread spectrum cycle (ssc) steps. The modulation frequency can be calculated with the TSSC bits in conjunction with the NSSC bits. Valid TSSC integer values for the modulation frequency range from 5 to 14. Values of 0 - 4 and 15 should not be used.

NSSC[2:0]

These bits are used to determine the number of delta-encoded samples used for a single quadrant of the spread spectrum waveform. All four quadrants of the spread spectrum waveform are mirror images of each other. The modulation frequency is also calculated based on the NSSC bits in conjunction with the TSSC bits. Valid NSSC integer

values range from 1 to 6. Values of 0 and 7 should not be used.

SS_OFFSET[5:0]

These bits are used to program the fractional offset with respect to the nominal M integer value. For center spread, the SS_OFFSET is set to '0' so that the spread spectrum waveform is centered about the nominal M (Mnom) value. For down spread, the SS_OFFSET > '0' such the spread spectrum waveform is centered about the (Mideal -1 +SS_Offset) value. The downspread percentage can be thought of in terms of center spread. For example, a downspread of -1% can also be considered as a center spread of ±0.5% but with Mnom shifted down by one and offset. The SS_OFFSET has integer values ranging from 0 to 63.

SD[3:0]

These bits are used to shape the profile of the spread spectrum waveform. These are delta-encoded samples of the waveform. There are twelve sets of SD samples. The NSSC bits determine how many of these samples are used for the waveform. The sum of these delta-encoded samples (sigma delta- encoded samples) determine the amount of spread and should not exceed (63 - SS_OFFSET). The maximum spread is inversely proportional to the nominal M integer value.

DITH

This bit is used for dithering the sigma-delta-encoded samples. This will randomize the least-significant bit of the input to the spread spectrum modulator. Set the bit to '1' to enable dithering.

X2

This bit will double the total value of the sigma-delta-encoded-samples which will increase the amplitude of the spread spectrum waveform by a factor of two. When X2 is '0', the amplitude remains nominal but if set to '1', the amplitude is increased by x2. The following equations govern how the spread spectrum is set:

$$T_{SSC} = TSSC[3:0] + 2 \text{ (Eq. 2)}$$

$$N_{SSC} = NSSC[2:0] * 2 \text{ (Eq. 3)}$$

$$SD[3:0]_k = S_{j+1}(\text{unencoded}) - S_j(\text{unencoded}) \text{ (Eq. 4)}$$

where S_j is the unencoded sample out of a possible 12 and

SD_k is the delta-encoded sample out of a possible 12.

$$\text{Amplitude} = ((2 * N[11:0] + A[3:0] + 1) * \text{Spread\%} / 100) / 2 \text{ (Eq. 5)}$$

if $1 < \text{Amplitude} < 2$, then set X2 bit to '1'.

Modulation frequency:

$$F_{PPFD} = F_{IN} / D \text{ (Eq. 6)}$$

$$F_{VCO} = F_{PPFD} * M_{NOM} \text{ (Eq. 7)}$$

$$F_{SSC} = F_{PPFD} / (4 * N_{SSC} * T_{SSC}) \text{ (Eq. 8)}$$

Spread:

$$\Sigma \Delta = SD_0 + SD_1 + SD_2 + \dots + SD_{11}$$

the number of samples used depends on the Nssc value

$$\Sigma \Delta \leq 63 - SS_OFFSET$$

$$\pm \text{Spread\%} = (\Sigma \Delta * 100) / (64 * (2 * N[11:0] + A[3:0] + 1)) \text{ (Eq. 9)}$$

$$\pm \text{Max Spread\%} / 100 = 1 / M_{NOM} \text{ or } 2 / M_{NOM} (X2=1)$$

Profile:

Waveform starts with SS_OFFSET, SS_OFFSET + SD_J, SS_OFFSET + SD_{J+1}, etc.

Spread Spectrum Using Sinusoidal Profile

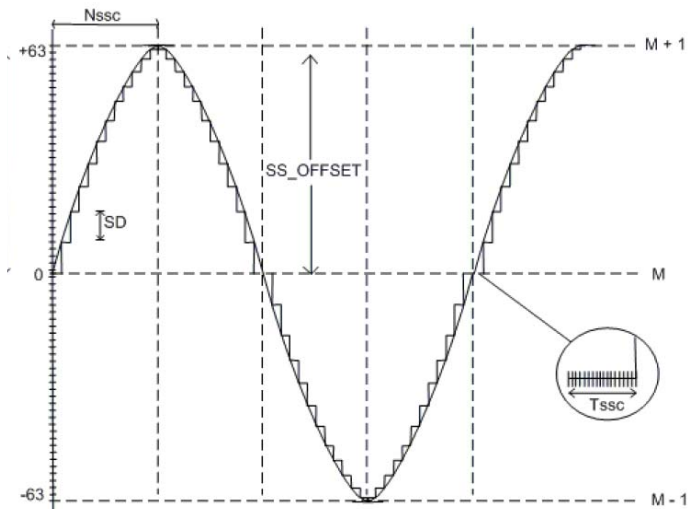

Example

$F_{IN} = 25\text{MHz}$, $F_{OUT} = 100\text{MHz}$, $F_{SSC} = 33\text{KHz}$ with center spread of $\pm 2\%$. Find the necessary spread spectrum register settings.

Since the spread is center, the SS_OFFSET can be set to '0'. Solve for the nominal M value; keep in mind that the nominal M should be chosen to maximize

the VCO. Start with $D = 1$, using Eq.6 and Eq.7.

$$M_{NOM} = 1200\text{MHz} / 25\text{MHz} = 48$$

Using Eq.4, we arbitrarily choose $N = 22$, $A = 3$. Now that we have the nominal M value, we can determine TSSC and NSSC by using Eq.8.

$$N_{SSC} * T_{SSC} = 25\text{MHz} / (33\text{KHz} * 4) = 190$$

However, using Eq. 2 and Eq.3, we find that the closest value is when TSSC = 14 and NSSC = 6. Keep in mind to maximize the number of samples used

to enhance the profile of the spread spectrum waveform.

$$T_{SSC} = 14 + 2 = 16$$

$$N_{SSC} = 6 * 2 = 12$$

$$N_{SSC} * T_{SSC} = 192$$

Use Eq.10 to determine the value of the sigma-delta-encoded samples.

$$\pm 2\% = (\Sigma\Delta * 100) / (64 * 48)$$

$$\Sigma\Delta = 61.4$$

Either round up or down to the nearest integer value. Therefore, we end up with 61 or 62 for sigma-delta-encoded samples. Since the sigma-delta-encoded samples must not exceed 63 with SS_OFFSET set to '0', 61 or 62 is well within the limits. It is the discretion of the user to define the shape of the profile that is better suited for the intended application.

Using Eq. 9 again, the actual spread for the sigma-delta-encoded samples of 56 and 57 are $\pm 1.99\%$ and $\pm 2.02\%$, respectively.

Use Eq.10 to determine if the X2 bit needs to be set;

$$\text{Amplitude} = 48 * (1.99 \text{ or } 2.02) / 100/2 = 0.48 < 1$$

Therefore, the X2 = '0'. The dither bit is left to the discretion of the user.

The example above was of a center spread using spread spectrum. For down spread, the nominal M value can be set one integer value lower to 47.

Note that the IDT5V49EE902 should not be programmed with TSSC > '0', SS_OFFSET = '0', and SD = '0' in order to prevent an unstable state in the modulator.

The PLL loop bandwidth must be at least 10x the modulation frequency along with higher damping (larger ω_{uz}) to prevent the spread spectrum from being filtered and reduce extraneous noise. Refer to the LOOP FILTER section for more detail on ω_{uz} . The A[3:0] must be used for spread spectrum, even if the total multiplier value is an even integer.

Spread Spectrum Generation (PLL3)

PLL3 support spread spectrum generation capability, which users have the option of turning on and off. Spread spectrum profile, frequency, and spread are fully programmable (within limits). The technique is different from that used in PLL0. The programmable spread spectrum generation parameters are SS_D3[7:0], SSVCO[15:0], SSENb, IP3[4:0] and RZ3[3:0] bits. These bits are in the memory address range of 0x4C to 0x85 for PLL3. The spread spectrum generation on PLL3 can be enabled/disabled using the SSENb bit. To enable spread spectrum, set SSENb = '1'.

For Spread Enabled:

Spread spectrum is configured using SS_D3(spread spectrum reference divide)

$$SS_D3 = \frac{F_{IN}}{4 * F_{MOD}} \quad (\text{Eq. 10})$$

and SSVCO (spread spectrum loop feedback counter).

$$SSVCO = [0.5 * \frac{F_{VCO}}{F_{MOD}} * (1 + SS/400) + 5] \quad (\text{Eq. 11})$$

SS is the total Spread Spectrum amount (I.e. center spread $\pm 0.5\%$ has a total spread of 1.0% and down spread -0.5% has a total spread of 0.5%.)

Loop Filter

The loop filter for each PLL can be programmed to optimize the jitter performance. The low-pass frequency response of the PLL is the mechanism that dictates the jitter transfer characteristics. The loop bandwidth can be extracted from the jitter transfer. A narrow loop bandwidth is good for jitter attenuation while a wide loop bandwidth is best for low-jitter frequency generation. The specific loop filter components that can be programmed are the resistor via the RZ[3:0] bits, zero capacitor via the CZ bit (for PLL0, PLL1 and PLL2), and the charge pump current via the IP[2:0] bits (for PLL0, PLL1 and PLL2) or IP[3:0] (for PLL3).

The following equations govern how the loop filter is set for PLL0 - PLL2:

$$\text{Resistor (Rz)} = (RZ[0] + 2 * RZ[1] + 4 * RZ[2] + 8 * RZ[3]) * 4.0 \text{ kOhm}$$

$$\text{Zero capacitor (Cz)} = 196 \text{ pF} + CZ * 217 \text{ pF}$$

$$\text{Pole capacitor (Cp)} = 15 \text{ pF}$$

$$\text{Charge pump (Ip)} = 6 * (IP[0] + 2 * IP[1] + 4 * IP[2]) \text{ uA}$$

$$\text{VCO gain (Kvco)} = 900 \text{ MHz/V} * 2\pi$$

The following equations govern how the loop filter is set for PLL3:

For Non-Spread Spectrum Operation:

$$\text{Resistor(Rz)} = \frac{(12.5 + 12.5 * (RZ[1] + 2 * RZ[2] + 4 * RZ[3]))}{* RZ[0] + 6 * (1 - RZ[0])} \text{ kOhms (Eq. 12)}$$

For Spread Spectrum Operation:

$$\text{Resistor(Rz)} = \frac{(62.5 + 12.5 * (RZ[1] + 2 * RZ[2] + 4 * RZ[3]))}{* RZ[0] + 6 * (1 - RZ[0])} \text{ kOhms (Eq. 13)}$$

$$\text{Zero capacitor (Cz)} = 250 \text{ pF}$$

$$\text{Pole capacitor (Cp)} = 15 \text{ pF}$$

For Non-Spread Spectrum Operation:

$$\text{Charge pump (Ip)} = \frac{24 * (1 + (2 * IP[0]) + (4 * IP[1]) + (8 * IP[2]))}{3 + (5 * IP[3]) + (11 * IP[4])} \text{ A (Eq. 14)}$$

For Spread Spectrum Operation:

$$\text{Charge pump (Ip)} = \frac{12 * (1 + (2 * IP[0]) + (4 * IP[1]) + (8 * IP[2]))}{27 + (5 * IP[3]) + (11 * IP[4])} \text{ A (Eq. 14)}$$

$$\text{VCO gain (Kvco)} = 900 \text{ MHz/V} * 2\pi$$

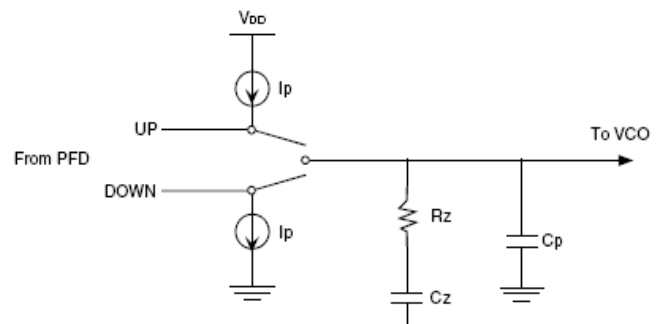

PLL Loop Bandwidth:

$$\text{Charge pump gain (K}\phi) = I_p / 2\pi$$

$$\text{VCO gain (K}_{VCO}) = 900 \text{ MHz/V} * 2\pi$$

M = Total multiplier value (See the Reference Divider, Feedback Divider and Output Divider section for more detail)

$$\omega_c = (R_z * K_\phi * K_{VCO} * C_z) / (M * (C_z + C_p))$$

$$F_c = \omega_c / 2\pi$$

Note, the phase/frequency detector frequency (F_{PFD}) is typically seven times the PLL closed-loop bandwidth (F_c) but too high of a ratio will reduce the phase margin thus compromising loop stability.

To determine if the loop is stable, the phase margin (ϕ_m) needs to be calculated as follows.

Phase Margin:

$$\omega_z = 1 / (R_z * C_z)$$

$$\omega_p = (C_z + C_p) / (R_z * C_z * C_p)$$

$$\phi_m = (360 / 2\pi) * [\tan^{-1}(\omega_c / \omega_z) - \tan^{-1}(\omega_c / \omega_p)]$$

To ensure stability in the loop, the phase margin is recommended to be $> 60^\circ$ but too high will result in the lock time being excessively long. Certain loop filter parameters would need to be compromised to not only meet a required loop bandwidth but to also maintain loop stability.

SEL[2:0] Function

The IDT5V49EE902 can support up to six unique configurations. Users may pre-programmed all these configurations, and select the configurations using SEL[2:0] pins. Alternatively, users may use I²C interface to configure these registers on-the-fly.

SEL2	SEL1	SEL0	Configuration Selections
0	0	0	Select CONFIG0
0	0	1	Select CONFIG1
0	1	0	Select CONFIG2
0	1	1	Select CONFIG3
1	0	0	Select CONFIG4
1	0	1	Select CONFIG5
1	1	0	Reserved (Do not use)
1	1	1	Reserved (Do not use)

Crystal/Clock Selection

XTCLKSEL bit is used to bypass a crystal oscillator circuit when external clock source is used.

PRMSRC bit is used to select a primary clock from XIN/REF and CLKIN.

PRMSRC bit	Primary	Secondary
0	XIN/REF	CLKIN
1	CLKIN	XIN/REF

CLKSEL input	Clock Source
0	Primary Clock Source
1	Secondary Clock Source

CLKSEL	PRMSRC	Reference Clock
0	0	XIN/REF
0	1	CLKIN
1	0	CLKIN
1	1	XIN/REF

SMx[1:0]	Switching Mode	Primary to Secondary	Secondary to Primary
0x	Manual	No	No
10	Auto	Yes	No
11	Auto-Revertive	Yes	Yes

SD/OE Pin Function

The polarity of the SD/OE signal pin can be programmed to be either active HIGH or LOW with the SP bit (0x02). When SP is “0” (default), the pin becomes active LOW and when SP is “1”, the pin becomes active HIGH. The SD/OE pin can be configured as either to shutdown the PLLs or to enable/disable the outputs.

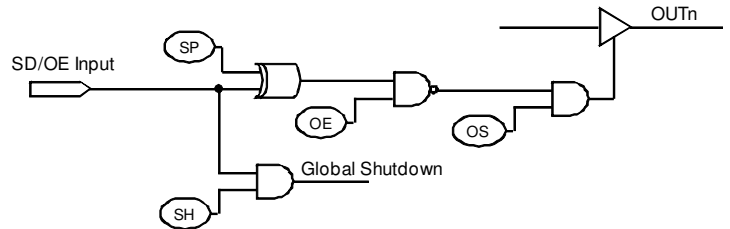

Truth Table

SH bit	SP bit	OSn bit	OEn bit	SD/OE	OUTn
0	0	0	x	x	High-Z ²
0	0	1	0	x	Enabled
0	0	1	1	0	Enabled
0	0	1	1	1	Suspended
0	1	0	x	x	High-Z ²
0	1	1	0	x	Enabled
0	1	1	1	0	Suspended
0	1	1	1	1	Enabled
1	0	0	x	0	High-Z ²
1	0	1	0	0	Enabled
1	0	1	1	0	Enabled
1	1	0	x	0	High-Z ²
1	1	1	0	0	Enabled
1	1	1	1	0	Suspended
1	x	x	x	1	Suspended ¹

Note 1 : Global Shutdown

Note 2 : Hi-Z regardless of OEM bits

Configuration OUTx IO Standard

Users can configure the individual output IO standard from a specified 1.8V to 3.3V power supplies. Each output can support 1.8V to 3.3V LVTTTL. Each output pair can support LVDS, LVPECL or HCSL from the specified 3.3V power supply. OUT0 can only be 3.3V single-ended output.

Programming the Device

I²C may be used to program the IDT5V49EE902.

– Device (slave) address = 7'b1101010

I²C Programming

The IDT5V49EE902 is programmed through an I²C-Bus serial interface, and is an I²C slave device. The read and write transfer formats are supported. The first byte of data after a write frame to the correct slave address is interpreted as the register address; this address auto-increments after each byte written or read.

The frame formats are shown in the following illustration.

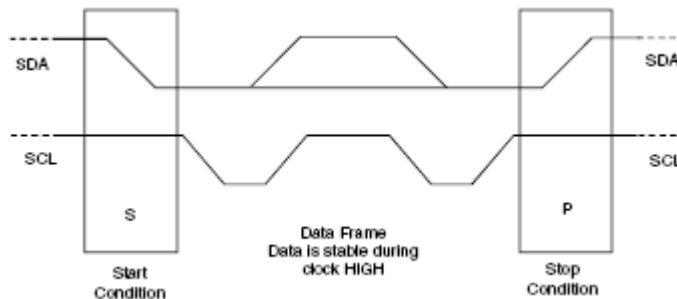

Framing

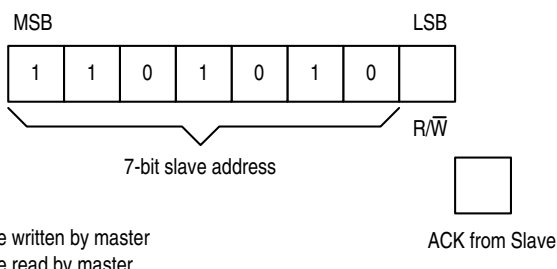

R/W
0 – Slave will be written by master
1 – Slave will be read by master

ACK from Slave

The first byte transmitted by the Master is the Slave Address followed by the R/W bit. The Slave acknowledges by sending a "1" bit.

First Byte Transmitted on I²C Bus

External I²C Interface Condition

KEY:

- From Master to Slave
- From Master to Slave, but can be omitted if followed by the correct sequence
Normally, data transfer is terminated by a STOP condition generated by the Master. However, if the Master still wishes to communicate on the bus, it can generate a separate START condition, and address another Slave address without first generating a STOP condition.
- From Slave to Master

SYMBOLS:

- ACK - Acknowledge (SDAT LOW)
- NACK – Not Acknowledge (SDAT HIGH)
- SR – Repeated Start Condition
- S – START Condition
- P – STOP Condition

Progwrite

S	Address	R/W	ACK	Command Code	ACK	Register	ACK	Data	ACK	P
	7-bits	0	1-bit	8-bits: xxxx xx00	1-bit	8-bits	1-bit	8-bits	1-bit	

Progwrite Command Frame

Writes can continue as long as a Stop condition is not sent and each byte will increment the register address.

Progreed

Note: If the expected read command is not from the next higher register to the previous read or write command, then set a known “read” register address prior to a read operation by issuing the following command:

S	Address	R/ \bar{W}	ACK	Command Code	ACK	Register	ACK	P
	7-bits	0	1-bit	8-bits: xxxx xx00	1-bit	8-bits	1-bit	

Prior to Progreed Command Set Register Address

The user can ignore the STOP condition above and use a repeated START condition instead, straight after the slave acknowledgement bit (i.e., followed by the Progreed command):

S	Address	R/ \bar{W}	ACK	ID Byte	ACK	Data_1	ACK	Data_2	ACK	Data_last	NACK	P
	7-bits	1	1-bit	8-bits	1-bit	8-bits	1-bit	8-bits	1-bit	8-bits	1-bit	

Progreed Command Frame

Progsave

S	Address	R/ \bar{W}	ACK	Command Code	ACK	P
	7-bits	0	1-bit	8-bits: xxxx xx01	1-bit	

Note:

PROGWRITE is for writing to the IDT5V49EE902 registers.

PROGREAD is for reading the IDT5V49EE902 registers.

PROGSAVE is for saving all the contents of the IDT5V49EE902 registers to the EEPROM.

PROGRESTORE is for loading the entire EEPROM contents to the IDT5V49EE902 registers.

Progrestore

S	Address	R/ \bar{W}	ACK	Command Code	ACK	P
	7-bits	0	1-bit	8-bits: xxxx xx10	1-bit	

EEPROM Interface

The IDT5V49EE902 can also store its configuration in an internal EEPROM. The contents of the device's internal programming registers can be saved to the EEPROM by issuing a save instruction (ProgSave) and can be loaded back to the internal programming registers by issuing a restore instruction (ProgRestore).

To initiate a save or restore using I²C, only two bytes are transferred. The Device Address is issued with the read/write bit set to “0”, followed by the appropriate command code. The save or restore instruction executes after the STOP condition is issued by the Master, during which time the IDT5V49EE902 will not generate Acknowledge bits. The IDT5V49EE902 will acknowledge the instructions after it has completed execution of them. During that time, the I²C bus should be interpreted as busy by all other users of the bus.

On power-up of the IDT5V49EE902, an automatic restore is performed to load the EEPROM contents into the internal programming registers. The IDT5V49EE902 will be ready to accept a programming instruction once it acknowledges its 7-bit I²C address.

I²C Bus DC Characteristics

Symbol	Parameter	Conditions	Min	Typ	Max	Unit
V _{IH}	Input HIGH Level		0.7xV _{DD}			V
V _{IL}	Input LOW Level				0.3xV _{DD}	V
V _{HYS}	Hysteresis of Inputs		0.05xV _{DD}			V
I _{IN}	Input Leakage Current				±1.0	µA
V _{OL}	Output LOW Voltage	I _{OL} = 3 mA			0.4	V

I²C Bus AC Characteristics for Standard Mode

Symbol	Parameter	Min	Typ	Max	Unit
F _{SCLK}	Serial Clock Frequency (SCL)	0		100	kHz
t _{BUF}	Bus free time between STOP and START	4.7			µs
t _{SU:START}	Setup Time, START	4.7			µs
t _{HD:START}	Hold Time, START	4			µs
t _{SU:DATA}	Setup Time, data input (SDA)	250			ns
t _{HD:DATA}	Hold Time, data input (SDA) ¹	0			µs
t _{OVD}	Output data valid from clock			3.45	µs
C _B	Capacitive Load for Each Bus Line			400	pF
t _R	Rise Time, data and clock (SDAT, SCLK)			1000	ns
t _F	Fall Time, data and clock (SDAT, SCLK)			300	ns
t _{HIGH}	HIGH Time, clock (SCLK)	4			µs
t _{LOW}	LOW Time, clock (SCLK)	4.7			µs
t _{SU:STOP}	Setup Time, STOP	4			µs

Note 1: A device must internally provide a hold time of at least 300 ns for the SDAT signal (referred to the V_{IH(MIN)} of the SCLK signal) to bridge the undefined region of the falling edge of SCLK.

I²C Bus AC Characteristics for Fast Mode

Symbol	Parameter	Min	Typ	Max	Unit
F _{SCLK}	Serial Clock Frequency (SCL)	0		400	kHz
t _{BUF}	Bus free time between STOP and START	1.3			μs
t _{SU:START}	Setup Time, START	0.6			μs
t _{HD:START}	Hold Time, START	0.6			μs
t _{SU:DATA}	Setup Time, data input (SDA)	100			ns
t _{HD:DATA}	Hold Time, data input (SDA) ¹	0			μs
t _{OVD}	Output data valid from clock			0.9	μs
C _B	Capacitive Load for Each Bus Line			400	pF
t _R	Rise Time, data and clock (SDA, SCL)	20 + 0.1xC _B		300	ns
t _F	Fall Time, data and clock (SDA, SCL)	20 + 0.1xC _B		300	ns
t _{HIGH}	HIGH Time, clock (SCL)	0.6			μs
t _{LOW}	LOW Time, clock (SCL)	1.3			μs
t _{SU:STOP}	Setup Time, STOP	0.6			μs

Note 1: A device must internally provide a hold time of at least 300 ns for the SDA signal (referred to the V_{IH}(MIN) of the SCL signal) to bridge the undefined region of the falling edge of SCL.

Absolute Maximum Ratings

Stresses above the ratings listed below can cause permanent damage to the IDT5V49EE902. These ratings, which are standard values for IDT commercially rated parts, are stress ratings only. Functional operation of the device at these or any other conditions above those indicated in the operational sections of the specifications is not implied. Exposure to absolute maximum rating conditions for extended periods can affect product reliability. Electrical parameters are guaranteed only over the recommended operating temperature range.

Symbol	Description	Min	Max	Unit
V_{DD}	Internal Power Supply Voltage	-0.5	+4.6	V
V_I	Input Voltage ¹	-0.5	+4.6	V
V_O	Output Voltage (not to exceed 4.6 V) ¹	-0.5	$V_{DD}+0.5$	V
T_J	Junction Temperature		150	°C
T_{STG}	Storage Temperature	-65	150	°C

1. Input negative and output voltage ratings may be exceeded if the input and output current ratings are observed.

Recommended Operation Conditions

Symbol	Parameter	Min	Typ	Max	Unit
V_{DD}	Power supply voltage for V_{DD} pins supporting core and outputs	3.135	3.3	3.465	V
V_{DDX}	Power supply voltage for crystal oscillator. Use filtered analog power supply if available.	3.135	3.3	3.465	V
AV_{DD}	Analog power supply voltage. Use filtered analog power supply if available.	3.135	3.3	3.6	V
V_{DDOX}	3.3V VDDO Range	3.0	3.3	3.465	V
	2.5V VDDO Range for 2.5V LVTTTL	2.25	2.5	2.75	V
	1.8V VDDO Range for 1.8V LVTTTL	1.7	1.8	1.9	V
	Power supply voltage for V_{DD} pins supporting LVDS/LVPECL/HCSL outputs	3.135	3.3	3.465	V
T_A	Operating temperature, ambient	-40		+85	°C
C_{LOAD_OUT}	Maximum load capacitance (3.3V LVTTTL only)			15	pF
	Maximum load capacitance (1.8V/2.5V LVTTTL only)			8	pF
F_{IN}	External reference crystal	8		50	MHz
	External reference clock CLKIN	1		200	
t_{PU}	Power up time for all V_{DD} s to reach minimum specified voltage (power ramps must be monotonic)	0.05		5	ms

Capacitance ($T_A = +25\text{ }^\circ\text{C}$)

Symbol	Parameter	Min	Typ	Max	Unit
C_{IN}	Input Capacitance (CLKIN, CLKSEL, SD/OE, SDA, SCL, SEL[2:0])		3	7	pF
Pull-down Resistor	CLKIN, CLKSEL, SD/OE, SEL[2:0]		180		k Ω
Crystal Specifications					
XTAL_FREQ	Crystal frequency	8		50	MHz
XTAL_MIN	Minimum crystal load capacitance	3.5			pF
XTAL_MAX	Maximum crystal load capacitance			35.5	pF
XTAL_V _{PP}	Voltage swing (peak-to-peak, nominal)	1.5	2.3	3.2	V

DC Electrical Characteristics for 3.3-V LVTTTL ¹

Symbol	Parameter	Test Conditions	Min	Typ	Max	Unit
V_{OH}	Output HIGH Voltage		2.4		V_{DD}	V
V_{OL}	Output LOW Voltage				0.4	V
V_{IH}	Input HIGH Voltage		2			V
V_{IL}	Input LOW Voltage				0.8	V
I_{OZDD}	Output Leakage Current	3-state outputs. $V_O = V_{DD}$ or GND, $V_{DD} = 3.6V$			10	μA

Note 1: See "Recommended Operating Conditions" table.

Power Supply Characteristics for PLLs and LVTTTL Outputs

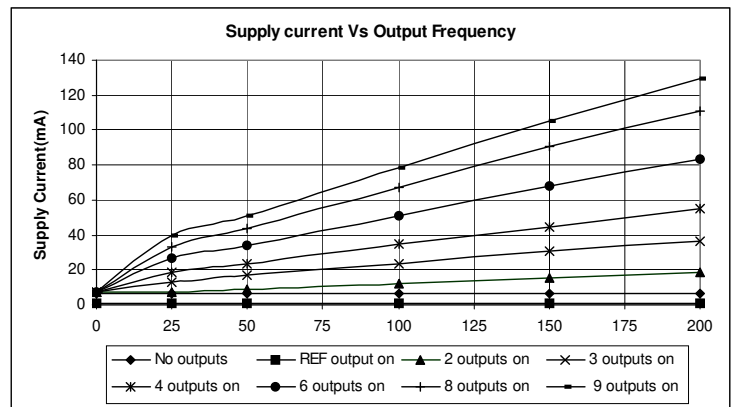
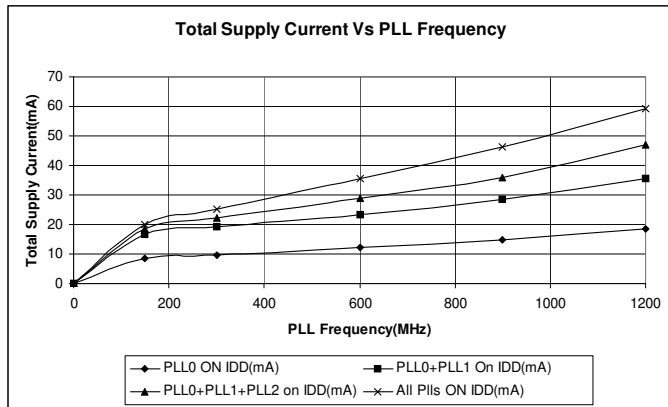

DC Electrical Characteristics for LVDS

Symbol	Parameter	Min	Typ	Max	Unit
$V_{OT (+)}$	Differential Output Voltage for the TRUE binary state	247		454	mV
$V_{OT (-)}$	Differential Output Voltage for the FALSE binary state	-247		-454	mV
ΔV_{OT}	Change in V_{OT} between Complimentary Output States			50	mV
V_{OS}	Output Common Mode Voltage (Offset Voltage)	1.125	1.2	1.375	V
ΔV_{OS}	Change in V_{OS} between Complimentary Output States			50	mV
I_{OS}	Outputs Short Circuit Current, V_{OUT+} or $V_{OUT-} = 0V$ or V_{DD}		9	24	mA
I_{OSD}	Differential Outputs Short Circuit Current, $V_{OUT+} = V_{OUT-}$		6	12	mA

Power Supply Characteristics for LVDS Outputs ¹

Symbol	Parameter	Test Conditions ²	Typ	Max	Unit
I_{DDQ}	Quiescent V_{DD} Power Supply Current	REF = LOW Outputs enabled, all outputs unloaded	68	90	mA
I_{DDD}	Dynamic V_{DD} Power Supply Current per Output	$V_{DD} = \text{Max.}$, $C_L = 0\text{pF}$	30	45	$\mu\text{A}/\text{MHz}$
I_{TOT}	Total Power V_{DD} Supply Current	$F_{\text{REFERENCE CLOCK}} = 100 \text{ MHz}$, $C_L = 2 \text{ pF}$	86	130	mA
		$F_{\text{REFERENCE CLOCK}} = 200 \text{ MHz}$, $C_L = 2 \text{ pF}$	100	150	
		$F_{\text{REFERENCE CLOCK}} = 400 \text{ MHz}$, $C_L = 2 \text{ pF}$	122	190	

Note 1: Output banks 4 and 5 are toggling. Other output banks are powered down.

Note 2: The termination resistors are excluded from these measurements.

DC Electrical Characteristics for LVPECL

Symbol	Parameter	Min	Typ	Max	Unit
V_{OH}	Output Voltage HIGH, terminated through 50Ω tied to $V_{DD}-2 \text{ V}$	$V_{DD}-1.2$		$V_{DD}-0.9$	V
V_{OL}	Output Voltage LOW, terminated through 50Ω tied to $V_{DD}-2 \text{ V}$	$V_{DD}-1.95$		$V_{DD}-1.61$	V
V_{SWING}	Peak-to-Peak Output Voltage Swing	0.55		0.93	V

Power Supply Characteristics for LVPECL Outputs ¹

Symbol	Parameter	Test Conditions ²	Typ	Max	Unit
I _{DDQ}	Quiescent V _{DD} Power Supply Current	REF = LOW Outputs enabled, all outputs unloaded	86	110	mA
I _{DDD}	Dynamic V _{DD} Power Supply Current per Output	V _{DD} = Max., C _L = 0pF	35	50	μA/MHz
I _{TOT}	Total Power V _{DD} Supply Current	F _{REFERENCE CLOCK} = 100 MHz, C _L = 2 pF	120	180	mA
		F _{REFERENCE CLOCK} = 200 MHz, C _L = 2 pF	130	190	
		F _{REFERENCE CLOCK} = 400 MHz, C _L = 2 pF	140	210	

Note 1: Output banks 4 and 5 are toggling. Other output banks are powered down.

Note 2: The termination resistors are excluded from these measurements.

DC Electrical Characteristics for HCSL

Symbol	Parameter	Min	Typ	Max	Unit
V _{OH}	Output Voltage HIGH	660	700	850	mV
V _{OL}	Output Voltage LOW	-150	0	27	mV
Crossing Point Voltage	Absolute	250	350	550	mV

Power Supply Characteristics for HCSL Outputs ¹

Symbol	Parameter	Test Conditions ²	Typ	Max	Unit
I _{DDQ}	Quiescent V _{DD} Power Supply Current	REF = LOW Outputs enabled, all outputs unloaded	68	90	mA
I _{DDD}	Dynamic V _{DD} Power Supply Current per Output	V _{DD} = Max., C _L = 0pF	30	45	μA/MHz
I _{TOT}	Total Power V _{DD} Supply Current	F _{REFERENCE CLOCK} = 100 MHz, C _L = 2 pF	86	130	mA
		F _{REFERENCE CLOCK} = 200 MHz, C _L = 2 pF	100	150	
		F _{REFERENCE CLOCK} = 400 MHz, C _L = 2 pF	122	190	

Note 1: Output banks 4 and 5 are toggling. Other output banks are powered down.

Note 2: The termination resistors are excluded from these measurements.

AC Timing Electrical Characteristics

(Spread Spectrum Generation = OFF)

Symbol	Parameter	Test Conditions	Min.	Typ.	Max.	Units
f_{IN}^1	Input Frequency	Input frequency limit (CLKIN)	1		200	MHz
		Input frequency limit (XIN/REF)	8		100	MHz
1 / t1	Output Frequency	Single ended clock output limit (LVTTTL)	0.001		200	MHz
		Differential clock output limit (LVPECL/ LVDS/HCSL)	0.001		500	MHz
f_{VCO}	VCO Frequency	VCO operating frequency range	100		1300	MHz
f_{PFD}	PFD Frequency	PFD operating frequency range	0.5 ¹		100	MHz
f_{BW}	Loop Bandwidth	Based on loop filter resistor and capacitor values	0.01		10	MHz
t2	Input Duty Cycle	Duty Cycle for input	40		60	%
t3	Output Duty Cycle	Measured at $V_{DD}/2$, all outputs except Reference output	45		55	%
		Measured at $V_{DD}/2$, Reference output	40		60	%
t4 ²	Slew Rate, SLEW[1:0] = 00	Single-ended 3.3V LVCMOS output clock rise and fall time, 20% to 80% of V_{DD} (Output Load = 5 pF)		3.5		V/ns
	Slew Rate, SLEW[1:0] = 01	Single-ended 3.3V LVCMOS output clock rise and fall time, 20% to 80% of V_{DD} (Output Load = 5 pF)		2.75		V/ns
	Slew Rate, SLEW[1:0] = 10	Single-ended 3.3V LVCMOS output clock rise and fall time, 20% to 80% of V_{DD} (Output Load = 5 pF)		2		V/ns
	Slew Rate, SLEW[1:0] = 11	Single-ended 3.3V LVCMOS output clock rise and fall time, 20% to 80% of V_{DD} (Output Load = 5 pF)		1.25		V/ns
t5	Rise Times	LVDS, 20% to 80%		600		ps
	Fall Times	LVDS, 80% to 20%		600		ps
	Rise Times	LVPECL, 20% to 80%		600		ps
	Fall Times	LVPECL, 80% to 20%		600		ps
	Rise Times	HCSL, From 0.175 V to 0.525 V	175	400	700	ps
	Fall Times	HCSL, From 0.525 V to 0.175 V	175	400	700	ps
t7	Clock Jitter ⁶	Peak-to-peak period jitter, 1PLL, multiple output frequencies switching, LVTTTL outputs		80	100	ps
		Peak-to-peak period jitter, all 4 PLLs on, LVTTTL outputs ³		200	270	ps
		Peak-to-peak period jitter, 1PLL, multiple output frequencies switching, LVPECL, LVDS or HCSL outputs		60	80	ps
		Peak-to-peak period jitter, all 4 PLLs on, LVPECL, LVDS or HCSL outputs		120	160	ps

Symbol	Parameter	Test Conditions	Min.	Typ.	Max.	Units
t8	Output Skew	Skew between output to output on the same bank			75	ps
t9 ⁴	Lock Time	PLL lock time from power-up		10	20	ms
t10 ⁵	Lock Time	PLL lock time from shutdown mode			2	ms

1. Practical lower frequency is determined by loop filter settings.

2. A slew rate of 2.75V/ns or greater should be selected for output frequencies of 100MHz or higher.

3. Jitter measured with clock outputs of 27 MHz, 48 MHz, 24.576 MHz, 74.25 MHz and 25 MHz.

4. Includes loading the configuration bits from EEPROM to PLL registers. It does not include EEPROM programming/write time.

5. Actual PLL lock time depends on the loop configuration.

6. Not guaranteed until customer specific configuration is approved by IDT.

Spread Spectrum Generation Specifications

Symbol	Parameter	Description	Min	Typ	Max	Unit
f _{IN} ¹	Input Frequency	Input Frequency Limit	1		400	MHz
f _{MOD}	Mod Frequency	Modulation Frequency		33	120	kHz
f _{SPREAD} ²	Spread Value	Amount of Spread Value (programmable) - Down Spread	-0.5		-4.0	%f _{OUT}
		Amount of Spread Value (programmable) - Center Spread	±0.25		±2.0	

1. Practical lower frequency is determined by loop filter settings.

2. Not guaranteed until customer specific configuration is approved by IDT.

Test Circuits and Conditions

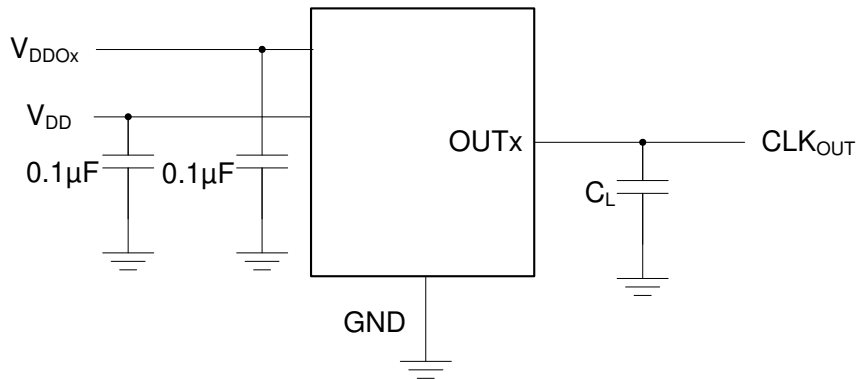

Test Circuits for DC Outputs

Other Termination Scheme (Block Diagram)

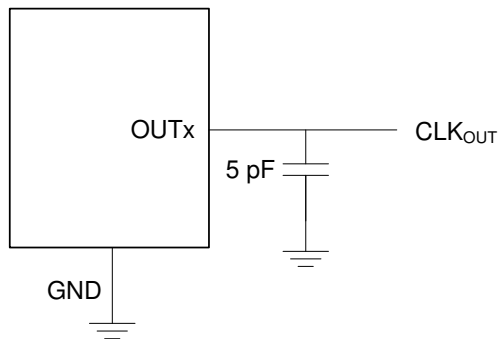

LVTTL: 5 pF for each output

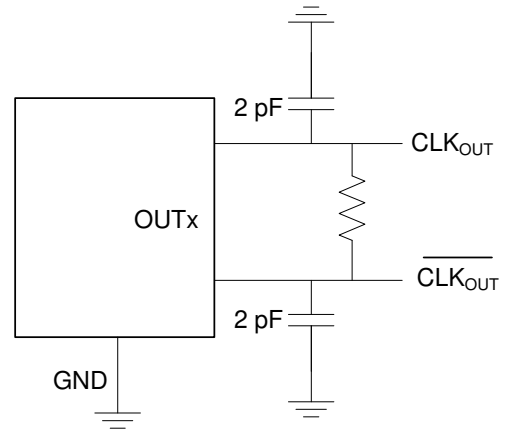

LVDS: 100Ω between differential outputs

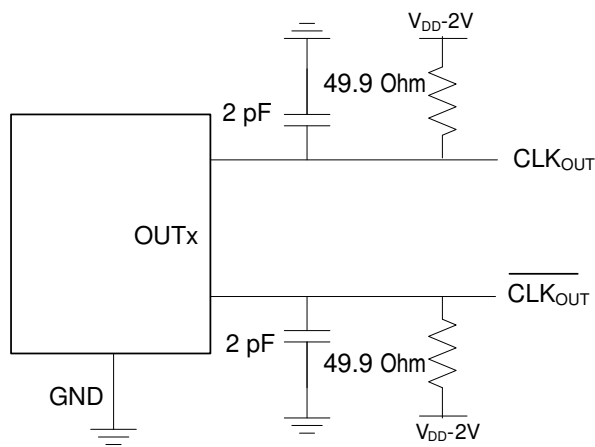

LVPECL

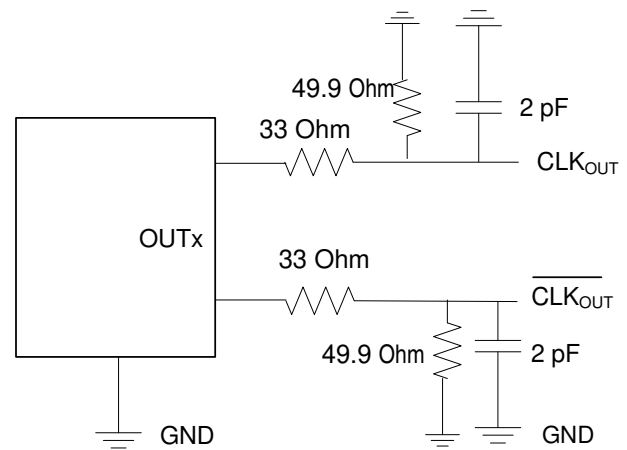

HCSSL

Programming Registers Table

Addr	Default Register Hex Value	Bit #								Description
		7	6	5	4	3	2	1	0	
0x00	00	Reserved							HW/SW	Hardware/Software Mode control HW/SW - 0=HW, 1=SW
0x01	00	Reserved				SEL[2:0]				SEL[2:0] - selects configuration in SW mode
0x02	02	SP	OE6	OE5	OE4	OE3	OE2	OE1	OE0	OE=Output Power Suspend function for OUTx ('1'=OUTx will be suspended on SD/OE pin. Disable mode is defined by OEMx bits, '0'=outputs enabled and no association with OE pin (default).
0x03	02	Reserved	OS*[6:0]							OS*[6:0] - output suspend, active low. Overrides OE setting.
0x04	0F	SH	Reserved			PLLS*[3:0]				PLLS*[3:0] - PLL Suspend, active low SH - shutdown/OE configuration
0x05	04	Reserved			XTCLKSEL	Reserved				XTCLKSEL - crystal/clock select. 0=Crytal, 1=ICLK
0x06	00	Reserved								
0x07	00	Reserved			XTAL[4:0]					XTAL[4:0] - crystal cap
0x08	00	Reserved								
0x09	00	Reserved								
0x0A	10	CZ0_CFG4	IP0[2:0]_CFG4			RZ0[3:0]_CFG4				PLL0 loop parameter
0x0B	10	CZ0_CFG5	IP0[2:0]_CFG5			RZ0[3:0]_CFG5				
0x0C	10	CZ0_CFG0	IP0[2:0]_CFG0			RZ0[3:0]_CFG0				
0x0D	10	CZ0_CFG1	IP0[2:0]_CFG1			RZ0[3:0]_CFG1				
0x0E	10	CZ0_CFG2	IP0[2:0]_CFG2			RZ0[3:0]_CFG2				
0x0F	10	CZ0_CFG3	IP0[2:0]_CFG3			RZ0[3:0]_CFG3				
0x10	00	Reserved	D0[6:0]_CFG0						PLL0 input divider and input sel D0[6:0] - 127 step Ref Div D0 = 0 means power down.	
0x11	00	Reserved	D0[6:0]_CFG1							
0x12	00	Reserved	D0[6:0]_CFG2							
0x13	00	Reserved	D0[6:0]_CFG3							
0x14	00	Reserved	D0[6:0]_CFG4							
0x15	00	Reserved	D0[6:0]_CFG5							
0x16	01	N0[7:0]_CFG4						N - Feedback Divider 2 - 4095 (values of "0" and "1" are not allowed) Total feedback with A, using provided calculation		
0x17	01	N0[7:0]_CFG5								
0x18	01	N0[7:0]_CFG0								
0x19	01	N0[7:0]_CFG1								
0x1A	01	N0[7:0]_CFG2								
0x1B	01	N0[7:0]_CFG3								
0x1C	00	A0[3:0]_CFG0			N0[11:8]_CFG0				PLL1 Loop Parameter	
0x1D	00	A0[3:0]_CFG1			N0[11:8]_CFG1					
0x1E	00	A0[3:0]_CFG2			N0[11:8]_CFG2					
0x1F	00	A0[3:0]_CFG3			N0[11:8]_CFG3					
0x20	00	A0[3:0]_CFG4			N0[11:8]_CFG4					
0x21	00	A0[3:0]_CFG5			N0[11:8]_CFG5					
0x22	10	CZ1_CFG4	IP1[2:0]_CFG4			RZ1[3:0]_CFG4				PLL1 Loop Parameter
0x23	10	CZ1_CFG5	IP1[2:0]_CFG5			RZ1[3:0]_CFG5				
0x24	10	CZ1_CFG0	IP1[2:0]_CFG0			RZ1[3:0]_CFG0				
0x25	10	CZ1_CFG1	IP1[2:0]_CFG1			RZ1[3:0]_CFG1				
0x26	10	CZ1_CFG2	IP1[2:0]_CFG2			RZ1[3:0]_CFG2				
0x27	10	CZ1_CFG3	IP1[2:0]_CFG3			RZ1[3:0]_CFG3				

Addr	Default Register Hex Value	Bit #								Description	
		7	6	5	4	3	2	1	0		
0x28	00	Reserved	D1[6:0]_CFG0								PLL1 input divider and input sel D1[6:0] - 127 step Ref Div D1 = 0 means power down.
0x29	00	Reserved	D1[6:0]_CFG1								
0x2A	00	Reserved	D1[6:0]_CFG2								
0x2B	00	Reserved	D1[6:0]_CFG3								
0x2C	00	Reserved	D1[6:0]_CFG4								
0x2D	00	Reserved	D1[6:0]_CFG5								
0x2E	01	N1[7:0]_CFG4								N - Feedback Divider 2 - 4095 (value of "0" is not allowed) Total feedback with A, using provided calculation	
0x2F	01	N1[7:0]_CFG5									
0x30	01	N1[7:0]_CFG0									
0x31	01	N1[7:0]_CFG1									
0x32	01	N1[7:0]_CFG2									
0x33	01	N1[7:0]_CFG3									
0x34	00	N3[11:8]_CFG0				N1[11:8]_CFG0				PLL3 Feedback Divider	
0x35	00	N3[11:8]_CFG1				N1[11:8]_CFG1					
0x36	00	N3[11:8]_CFG2				N1[11:8]_CFG2					
0x37	00	N3[11:8]_CFG3				N1[11:8]_CFG3					
0x38	00	N3[11:8]_CFG4				N1[11:8]_CFG4					
0x39	00	N3[11:8]_CFG5				N1[11:8]_CFG5					
0x3A	00	CZ2_CFG4	IP2[2:0]_CFG4			RZ2[3:0]_CFG4				PLL2 Loop Parameter	
0x3B	00	CZ2_CFG5	IP2[2:0]_CFG5			RZ2[3:0]_CFG5					
0x3C	00	CZ2_CFG0	IP2[2:0]_CFG0			RZ2[3:0]_CFG0					
0x3D	00	CZ2_CFG1	IP2[2:0]_CFG1			RZ2[3:0]_CFG1					
0x3E	00	CZ2_CFG2	IP2[2:0]_CFG2			RZ2[3:0]_CFG2					
0x3F	00	CZ2_CFG3	IP2[2:0]_CFG3			RZ2[3:0]_CFG3					
0x40	00	Reserved	D2[6:0]_CFG0								PLL2 Reference Divide and Input Select D2[6:0] - 127 step Ref Div D2 = 0 means power down.
0x41	00	Reserved	D2[6:0]_CFG1								
0x42	00	Reserved	D2[6:0]_CFG2								
0x43	00	Reserved	D2[6:0]_CFG3								
0x44	00	Reserved	D2[6:0]_CFG4								
0x45	00	Reserved	D2[6:0]_CFG5								
0x46	01	N2[7:0]_CFG4								N2[7:0] - PLL2 Feedback Divider 2 - 4095 (value of "0" is not allowed). (See Addr 0x4C:0x51 for N2[15:8])	
0x47	01	N2[7:0]_CFG5									
0x48	01	N2[7:0]_CFG0									
0x49	01	N2[7:0]_CFG1									
0x4A	01	N2[7:0]_CFG2									
0x4B	01	N2[7:0]_CFG3									
0x4C	80	SSENB_CFG0	0	0	IP3[4]_CFG0	N2[11:8]_CFG0				N2[11:8] - PLL2 Feedback Divide PLL3 Spread Spectrum SSENB - Spread Spectrum Enable SSENB = 1 means ON IP3[4:0] - PLL3 Charge Pump Current.	
0x4D	80	SSENB_CFG1	0	0	IP3[4]_CFG1	N2[11:8]_CFG1					
0x4E	80	SSENB_CFG2	0	0	IP3[4]_CFG2	N2[11:8]_CFG2					
0x4F	80	SSENB_CFG3	0	0	IP3[4]_CFG3	N2[11:8]_CFG3					
0x50	80	SSENB_CFG4	0	0	IP3[4]_CFG4	N2[11:8]_CFG4					
0x51	80	SSENB_CFG5	0	0	IP3[4]_CFG5	N2[11:8]_CFG5					
0x52	XX ¹	Reserved									
0x53	XX ¹	Reserved									
0x54	XX ¹	Reserved									
0x55	XX ¹	Reserved									