



Chipsmall Limited consists of a professional team with an average of over 10 year of expertise in the distribution of electronic components. Based in Hongkong, we have already established firm and mutual-benefit business relationships with customers from,Europe,America and south Asia,supplying obsolete and hard-to-find components to meet their specific needs.

With the principle of “Quality Parts,Customers Priority,Honest Operation,and Considerate Service”,our business mainly focus on the distribution of electronic components. Line cards we deal with include Microchip,ALPS,ROHM,Xilinx,Pulse,ON,Everlight and Freescale. Main products comprise IC,Modules,Potentiometer,IC Socket,Relay,Connector.Our parts cover such applications as commercial,industrial, and automotives areas.

We are looking forward to setting up business relationship with you and hope to provide you with the best service and solution. Let us make a better world for our industry!



Contact us

Tel: +86-755-8981 8866 Fax: +86-755-8427 6832

Email & Skype: info@chipsmall.com Web: www.chipsmall.com

Address: A1208, Overseas Decoration Building, #122 Zhenhua RD., Futian, Shenzhen, China



THIS DRAWING IS UNPUBLISHED. RELEASED FOR PUBLICATION - N/A .
 © COPYRIGHT N/A By - ALL RIGHTS RESERVED.

LOC	DIST	REVISIONS					
DF	B0	P	LTR	DESCRIPTION	DATE	DWN	APVD
		V		REV PER ECO-11-011379	20JUN11	PY	DE

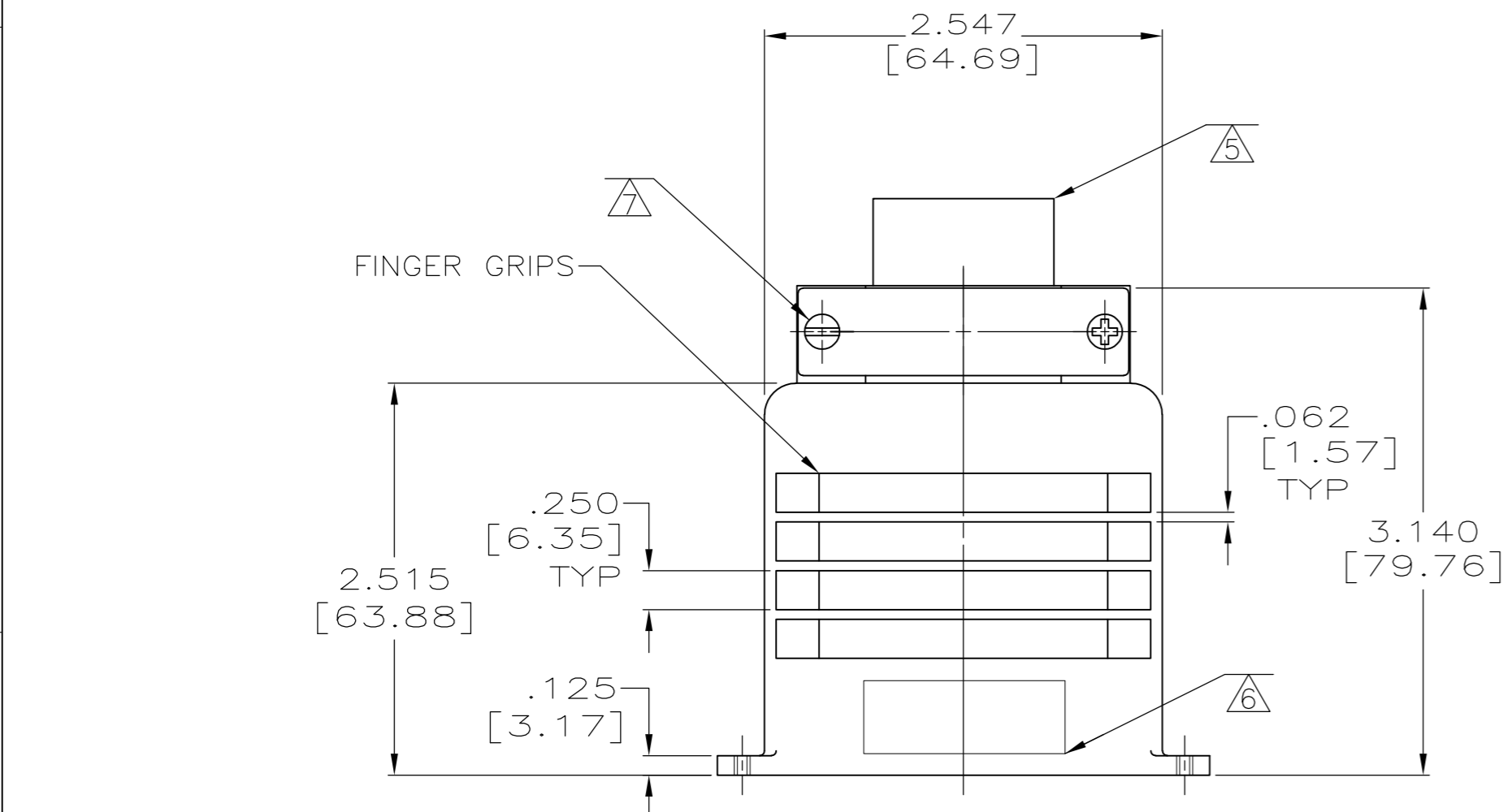
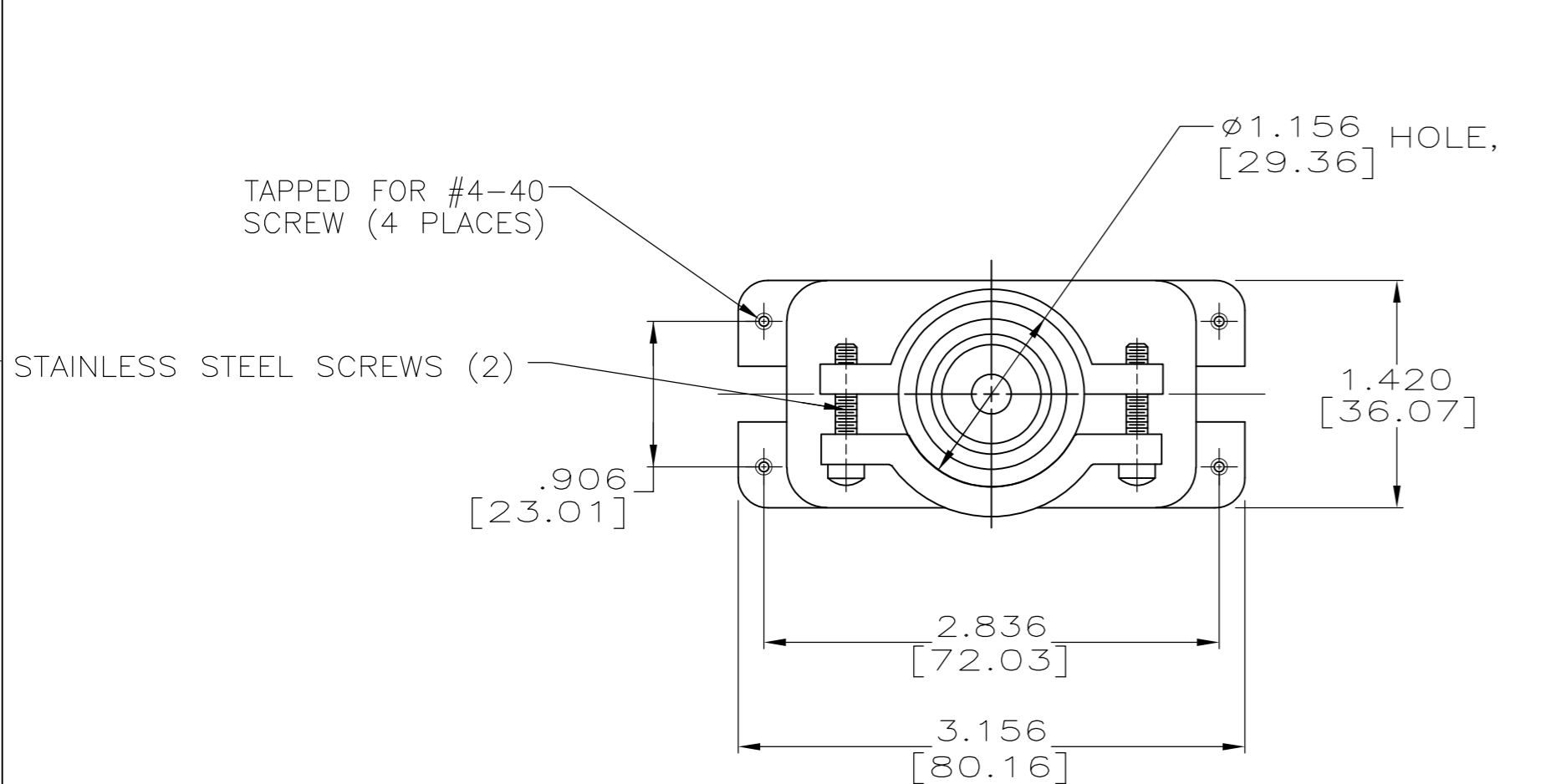

- ① ZINC PLATE PER ASTM B633 TYPE II .0002 [0.005] TO .0004 [0.010] THICK, GOLD CHROMATE.
- ② ZINC PLATE PER ASTM B633, TYPE II .0002 [0.005] TO .0004 [0.010] THICK, OLIVE DRAB CHROMATE.
- ③ ZINC PLATE PER ASTM B633 TYPE III .0002 [0.005] TO .0004 [0.010] THICK, CLEAR CHROMATE.
- ④ ZINC PLATE PER ASTM B633 TYPE II CLASS 3 COLORLESS SUPPLEMENTARY CHROMATE.
- ⑤ FOUR RUBBER BUSHINGS SUPPLIED TO, PROVIDE .250 [6.35], .625 [15.88], .750 [19.05] AND .937 [23.81], DIAMETER OUTLETS.
- 6. AMP 202301-X AND DATE CODE MARKED APPROXIMATELY AS SHOWN.
- ⑦ STANDARD FILLISTER HEAD SCREW, 1--0, 1--1, 1--3, 6--0 & 6--1.
- 8. SHIELD TO ACCOMMODATE MODULE RECEPTACLE ASSEMBLY OR PLUG ASSEMBLY.
- ⑨ BULK PACKAGED.
- ⑩ PLATED ELECTROLESS NICKEL PER SAE-AMS-C-26074, .000400[0.010]-.000800[0.020] THK (NO INTENTIONAL ADDITIONS OF LEAD OR CADMIUM PER DFE STANDARD 230-700).

OBSOLETE	⑦	YES	YES	⑩	6-202301-1
	⑦	YES	NO	⑩	6-202301-0
OBSOLETE	-	YES	YES	⑩	5-202301-5
OBSOLETE	⑦⑨	YES	YES	③	1-202301-3
OBSOLETE	-	YES	YES	①	1-202301-2
SUPERSEDED BY 6-202301-1	⑦	YES	YES	③	1-202301-1
SUPERSEDED BY 6-202301-0	⑦	YES	NO	③	1-202301-0
	-	YES	NO	③	202301-9
	-	YES	NO	②	202301-8
OBSOLETE	-	NO	NO	③	202301-7
OBSOLETE	-	YES	YES	②	202301-6
SUPERSEDED BY 5-202301-5	-	YES	YES	③	202301-5
OBSOLETE	-	NO	NO	②	202301-4
OBSOLETE	-	NO	NO	④	202301-3
OBSOLETE	-	NO	YES	②	202301-2
OBSOLETE	-	NO	YES	④	202301-1

REMARKS	FINGER GRIPS BOTH SIDES	BUSHINGS	FINISH	PART NUMBER
		⑤		

THIS DRAWING IS A CONTROLLED DOCUMENT.

DWN: JESSE A BAKER 15-JAN-93
 CHK: DALE MUMMEY 15-JAN-93
 APVD: DALE MUMMEY 15-JAN-93

TE Connectivity

SHIELD FOR MODULE ASSY
 3 BLOCK ASSY
 SERIES G

DIMENSIONS: INCHES
 TOLERANCES UNLESS OTHERWISE SPECIFIED:
 0 PLC ± -
 1 PLC ± -
 2 PLC ± -
 3 PLC ± .015[0.38]
 4 PLC ± -
 ANGLES ± 0°30'

MATERIAL: DIE CAST ALUM QQ-A-591
 FINISH: SEE TABLE

WEIGHT: -
 CUSTOMER DRAWING

SIZE: A2
 CAGE CODE: 00779
 DRAWING NO: C-202301
 RESTRICTED TO: -

SCALE: 1:1
 SHEET: 1 of 1
 REV: V