



Chipsmall Limited consists of a professional team with an average of over 10 year of expertise in the distribution of electronic components. Based in Hongkong, we have already established firm and mutual-benefit business relationships with customers from,Europe,America and south Asia,supplying obsolete and hard-to-find components to meet their specific needs.

With the principle of “Quality Parts,Customers Priority,Honest Operation,and Considerate Service”,our business mainly focus on the distribution of electronic components. Line cards we deal with include Microchip,ALPS,ROHM,Xilinx,Pulse,ON,Everlight and Freescale. Main products comprise IC,Modules,Potentiometer,IC Socket,Relay,Connector.Our parts cover such applications as commercial,industrial, and automotives areas.

We are looking forward to setting up business relationship with you and hope to provide you with the best service and solution. Let us make a better world for our industry!



## Contact us

Tel: +86-755-8981 8866 Fax: +86-755-8427 6832

Email & Skype: info@chipsmall.com Web: www.chipsmall.com

Address: A1208, Overseas Decoration Building, #122 Zhenhua RD., Futian, Shenzhen, China



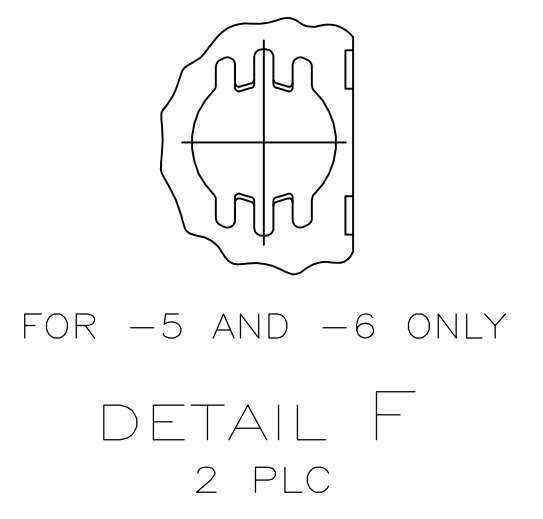
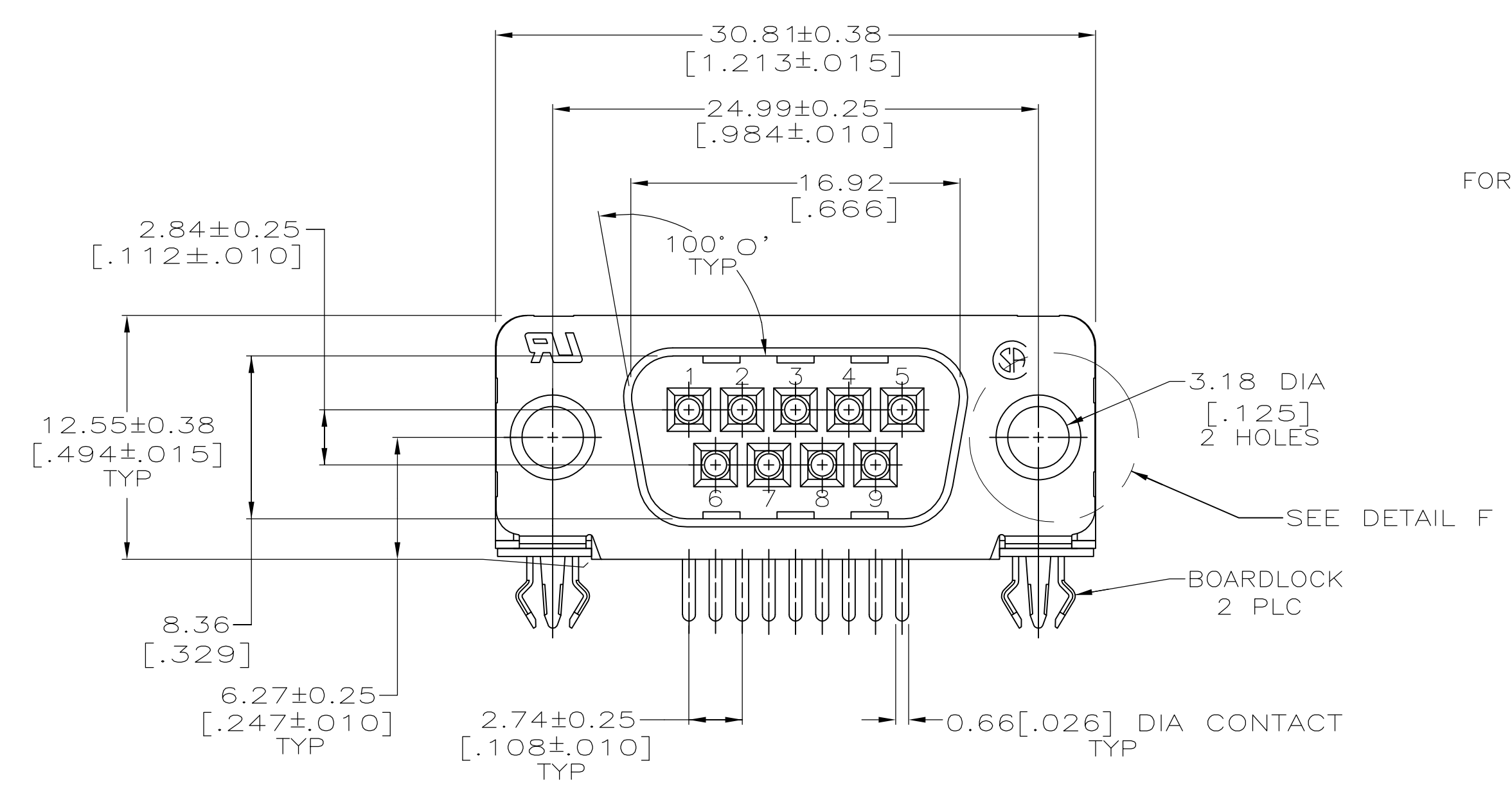

- ① HOUSING: NYLON OR POLYESTER, FLAME RETARDANT 94V-0 RATED, GLASS FILLED, BLACK  
 SHELLS: CARBON STEEL  
 CONTACTS: BRASS  
 BOARDLOCKS: COPPER ALLOY  
 EYELETS: BRASS
- ② SHELLS: 2.54µm[.000100] MIN TIN OVER 1.27µm[.000050] MIN COPPER.  
 EYELETS: 5.08µm[.000200] MIN TIN OVER COPPER FLASH.  
 CONTACTS AND BOARDLOCKS: SEE TABLE.
- ③ GOLD FLASH ON THE MATING SURFACES, 2.54µm[.000100] MIN TIN OR TIN-LEAD PLATE ON THE SOLDER END, 1.27µm[.000050] MIN NICKEL UNDERPLATE ON THE ENTIRE CONTACT.
- ④ 0.76µm[.000030] MIN GOLD PLATE ON THE MATING SURFACES, 2.54µm[.000100] MIN TIN OR TIN-LEAD PLATE ON THE SOLDER END, 1.27µm[.000050] MIN NICKEL UNDERPLATE ON THE ENTIRE CONTACT  
 -OR-  
 GOLD FLASH OVER PALLADIUM-NICKEL PLATE, 0.76µm[.000030] MIN TOTAL ON THE MATING SURFACES, 2.54µm[.000100] MIN TIN OR TIN-LEAD PLATE ON THE SOLDER END, 1.27µm[.000050] MIN NICKEL UNDERPLATE ON THE ENTIRE CONTACT.
- ⑤ 5.08µm[.000200] MIN TIN-LEAD OVER 1.27µm[.000050] MIN NICKEL.
- ⑥ 5.08µm[.000200] MIN TIN OVER 1.27µm[.000050] MIN NICKEL.
- ⑦ DIMENSION APPLIES FROM CENTER OF CONTACTS.
- ⑧ CLEAR CHROMATE.
- ⑨ OBSOLETE PARTS: OBSOLETE CIS STREAMLINING PER D.RENAUD/D.SINISI.

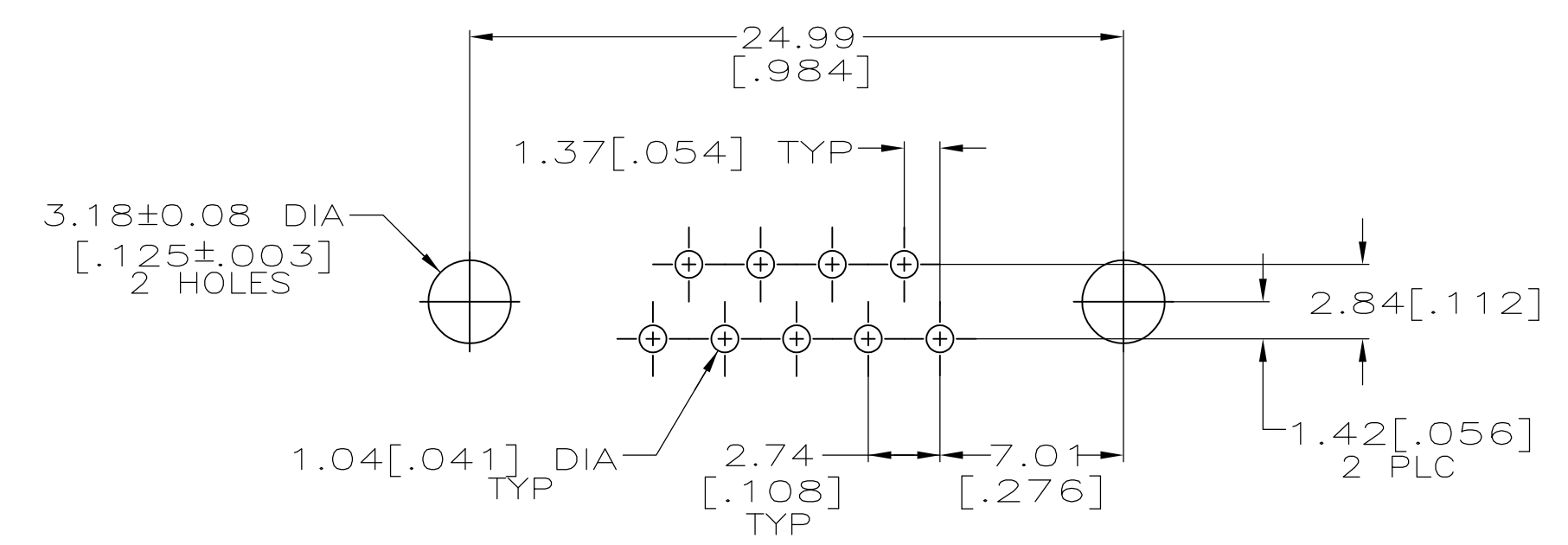
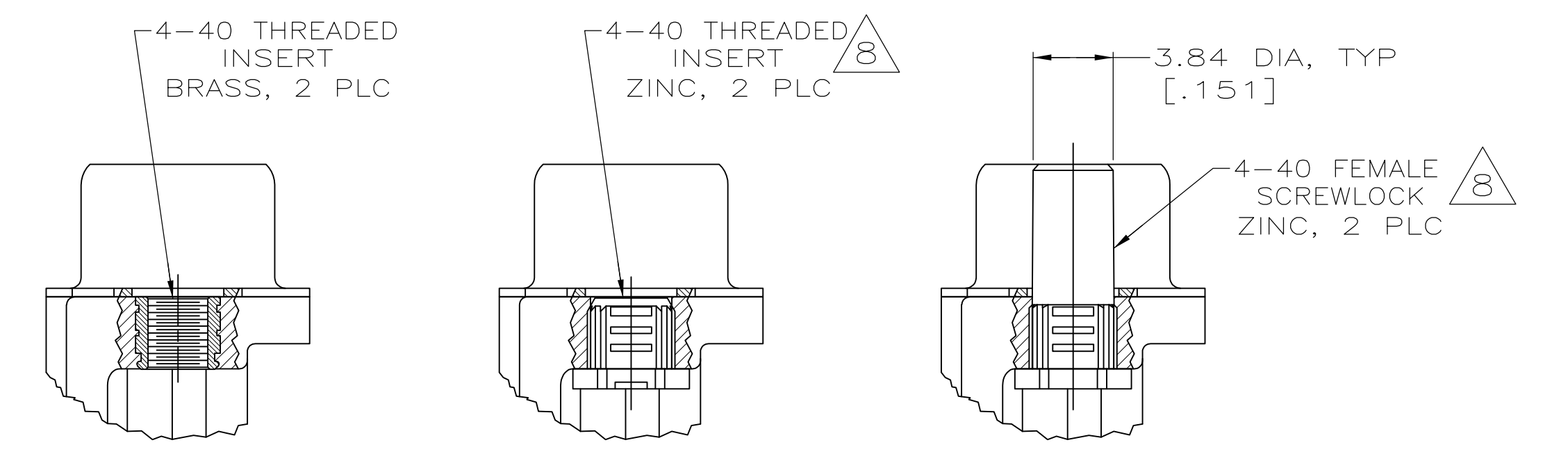
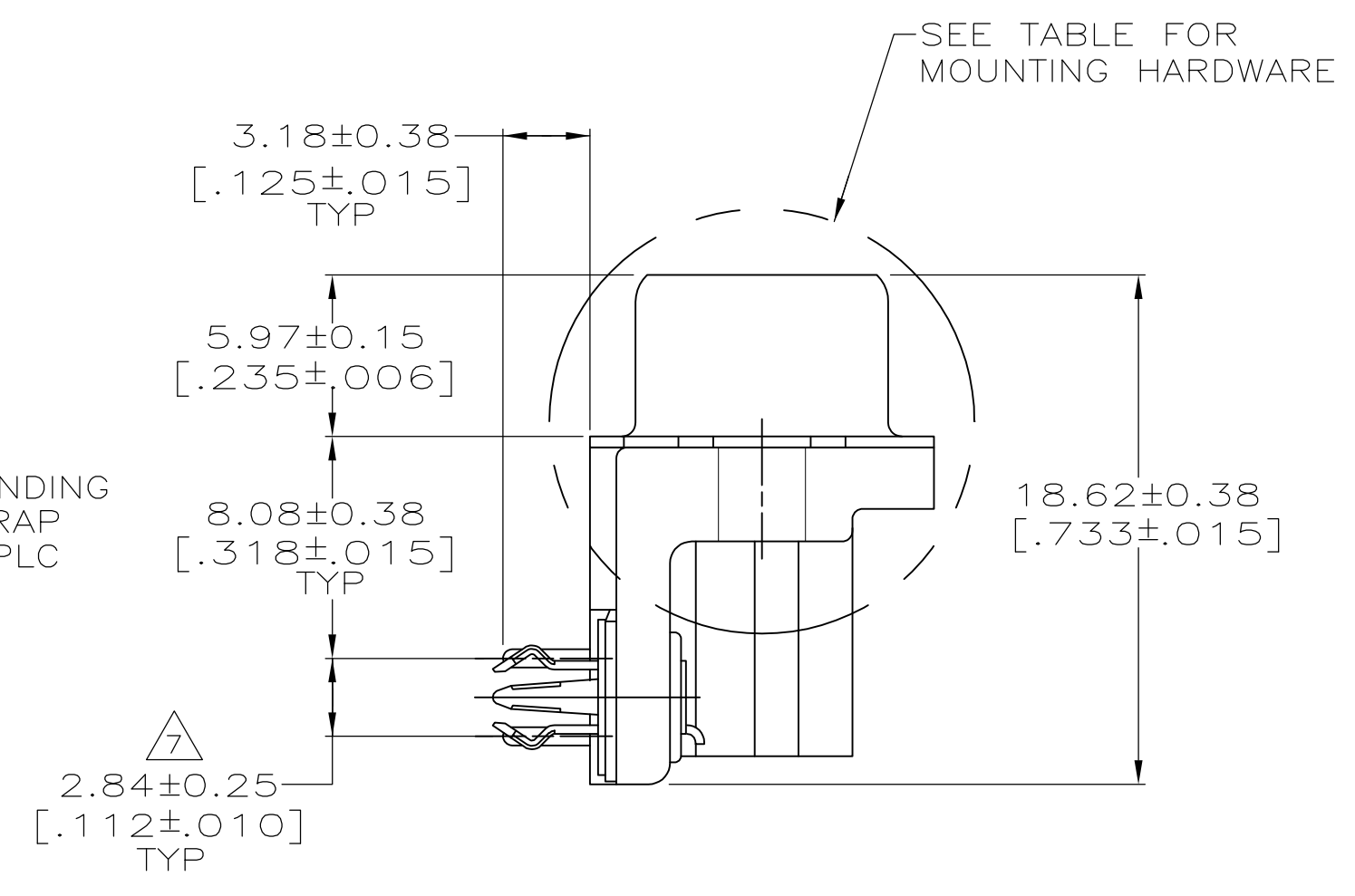
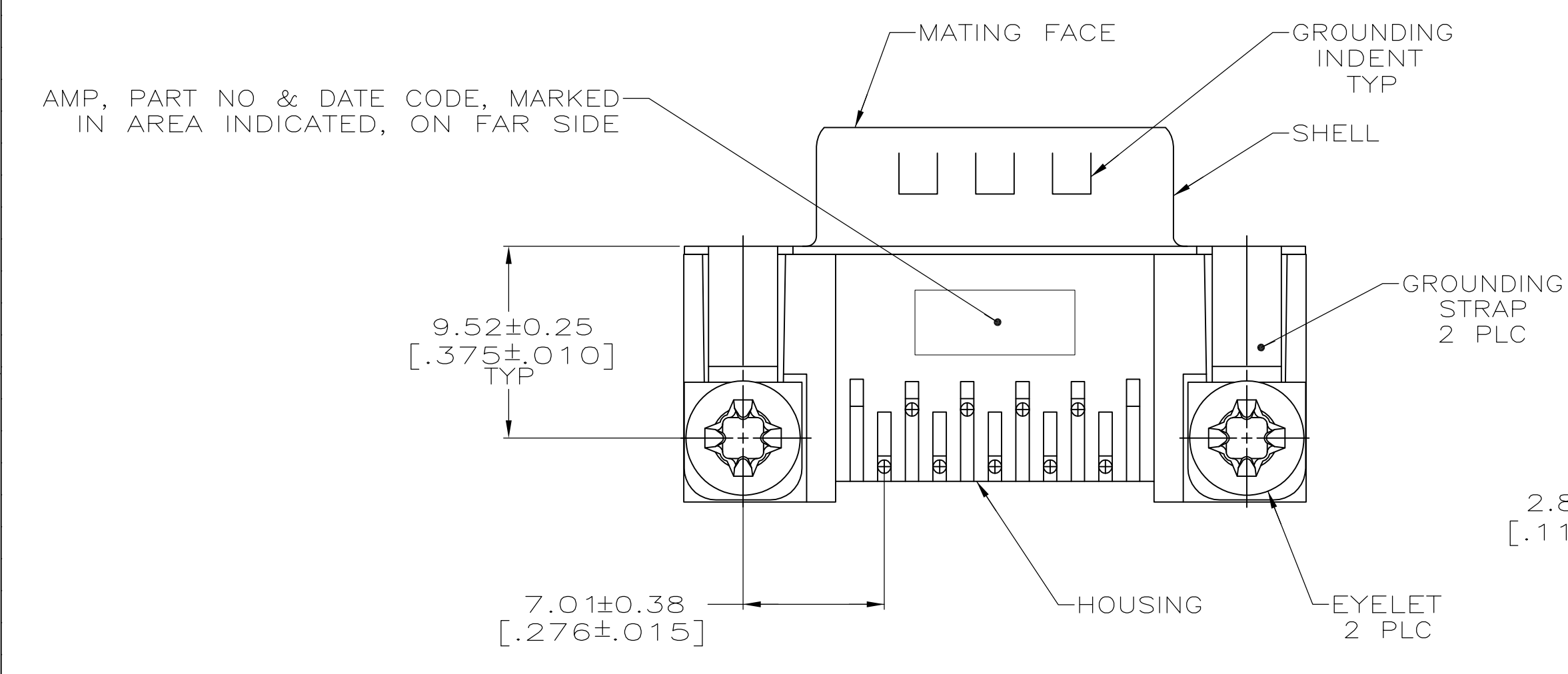

	TRAY	SEE DETAIL E	⑥	④	7-747840-1
	-	SEE DETAIL E	⑥	③	7-747840-0
	TRAY	SEE DETAIL D	⑥	④	6-747840-9
⑨	OBSOLETE TRAY	SEE DETAIL D	⑥	③	-6-747840-8
⑨	OBSOLETE TRAY	-	⑥	④	-6-747840-7
	OBSOLETE TRAY SPECIAL	SEE DETAIL D	⑤	④	1-747840-2
SUPSD BY 747840-6	TUBE	SEE DETAIL E	⑤	④	1-747840-0
SUPSD BY 747840-3	TUBE	SEE DETAIL D	⑤	③	747840-9
SUPSD BY 747840-4	TUBE	SEE DETAIL D	⑤	④	747840-8
	OBSOLETE TRAY	SEE DETAIL C	⑤	③	747840-7
	TRAY	SEE DETAIL E	⑤	④	747840-6
	TRAY	SEE DETAIL E	⑤	③	747840-5
	TRAY	SEE DETAIL D	⑤	④	747840-4
	TRAY	SEE DETAIL D	⑤	③	747840-3
SUPSD BY 5747840-2	-	-	⑤	④	747840-2
SUPSD BY 5747840-2	-	-	⑤	③	747840-1
	PACKAGING	MOUNTING HARDWARE	BOARDLOCK FINISH	CONTACT FINISH	PART NUMBER

THIS DRAWING IS A CONTROLLED DOCUMENT. DIMENSIONING AND TOLERANCING PER ASME Y14.5M-2009.

W.G. LENKER 05 OCT 89  
 R. STONE 05 FEB 90  
 M.D. GALLOWAY 06 FEB 90

STE TE Connectivity

NAME: PLUG ASSEMBLY, SIZE 1, 9 POSITION, RIGHT ANGLE, FRONT METAL SHELL, .318 SERIES, BOARDLOCKS, AMPLIMITE® HD-20

PRODUCT SPEC: 108-40025  
 APPLICATION SPEC: 114-40010

SIZE: A1  
 CAGE CODE: 00779  
 DRAWING NO: 747840

RESTRICTED TO: CUSTOMER DRAWING  
 SCALE: 4:1  
 SHEET: 1 of 1  
 REV: Z