



Chipsmall Limited consists of a professional team with an average of over 10 year of expertise in the distribution of electronic components. Based in Hongkong, we have already established firm and mutual-benefit business relationships with customers from,Europe,America and south Asia,supplying obsolete and hard-to-find components to meet their specific needs.

With the principle of “Quality Parts,Customers Priority,Honest Operation,and Considerate Service”,our business mainly focus on the distribution of electronic components. Line cards we deal with include Microchip,ALPS,ROHM,Xilinx,Pulse,ON,Everlight and Freescale. Main products comprise IC,Modules,Potentiometer,IC Socket,Relay,Connector.Our parts cover such applications as commercial,industrial, and automotives areas.

We are looking forward to setting up business relationship with you and hope to provide you with the best service and solution. Let us make a better world for our industry!



Contact us

Tel: +86-755-8981 8866 Fax: +86-755-8427 6832

Email & Skype: info@chipsmall.com Web: www.chipsmall.com

Address: A1208, Overseas Decoration Building, #122 Zhenhua RD., Futian, Shenzhen, China





Optical Encoders 600 Series



600 Series Optical Encoders

The 600 Series Optical Encoders use non-contact technology to convert mechanical rotary motion into a digital electrical output. This output, compatible with transistor-transistor logic (TTL), may eliminate the need for analog to digital converters.

These encoders are rotary devices which contain a rotor and stator pair that create a variable aperture to allow light from a light emitting diode (LED) to pass through to a photosensitive diode. The rotor represents the number of lines (pulses) of the encoder and the stator creates the positioning of the individual outputs, or phasing. The varying amount of light allowed through the aperture creates a sine wave output. Internal electronics then amplify and convert this sine wave output into a square wave.

Two square waves, Channel A and Channel B, provide a quadrature output. Channel A leads Channel B by 90° electrically in a counterclockwise direction at a rate of 128 pulses per channel per revolution. Quadrature output allows the user to potentially determine incremental position, direction and speed.

The 600 Series is available with PC terminals, cable, or cable with connector.

Key Features and Benefits

- **Non-contact technology, with a minimum of 10 million shaft rotations:** Promotes long life in the application
- **Digital voltage output:** May eliminate the need for analog to digital converters, contributes to a more cost-effective solution
- **TTL-compatible output:** Prevents triggering of false highs/lows due to ambient noise
- **Wide operating temperature range of -40 °C to 65 °C [-40 °F to 149 °F]:** Promotes flexibility in the applications
- **Choice of mounting terminations:** Designed to provide mounting flexibility

Potential Applications

INDUSTRIAL

- Motor control
- Flow control
- Robotics
- Computer peripherals
- Welding equipment

MEDICAL

- Portable diagnostic equipment (i.e., EKG, ultrasound)
- Home healthcare respiratory equipment
- Surgical equipment
- Precision joysticks

Optical Encoders, 600 Series

Table 1. Electrical Specifications

Characteristic	Parameter			
	600-128-C24	600-128-B66	600-128-CBL	600-128-CN1
				
Electrical travel	continuous/360°			
Input voltage	5 Vdc ±5%			
Output voltage: high low	2.4 V min. with 10 kOhm load to ground 0.4 V, max.			
Output rate	128 pulses/revolution per channel			
Supply current	30 mA, max.			
Channels	two separate output channels in quadrature, 90° ±45°			

Table 2. Mechanical Specifications

Characteristic	Parameter			
	600-128-C24	600-128-B66	600-128-CBL	600-128-CN1
Mechanical travel	continuous/360°			
Operating speed	300 RPM, max.			
Operating torque	0,011 N m [1.5 in oz], max.			
Rotational life	10 million shaft rotations, min.			
Shaft: diameter end play radial play axial force material	6,35 mm [0.25 in] 0,127 mm [0.005 in], max. 0,254 mm [0.010 in] at 25,4 mm [1 in] 6,8 kg [15 lb] push/pull stainless steel			
Bushing: diameter/thread size material	9,53 mm [0.375 in] x 32 NEF 2A nickel-plated brass			
Termination type and material	PC, type C-24, 4-pin, gold-plated	PC, type B-66, 4-pin, gold-plated	cable with four-lead ribbon, 28 AWG, IL-W-168780 Type B or equivalent insulation	cable with Berg connector, 28 AWG, IL-W-168780 Type B or equivalent insulation
Terminal strength	2 lb push or pull			
Mounting hardware material: mounting nut lockwasher	nickel-plated brass nickel-plated brass			
Sealing	Controls are not sealed for board washing. Consult Honeywell for details.			

Optical Encoders, 600 Series

Table 3. Environmental Specifications

Characteristic	Parameter			
	600-128-C24	600-128-B66	600-128-CBL	600-128-CN1
Operating temperature	-40 °C to 65 °C [-40 °F to 149 °F]			
Storage temperature	-55 °C to 110 °C [-67 °F to 230 °F]			
Humidity	85 %RH at 40 °C [104 °F] 240 hr			

Figure 1. Mounting Dimensions (For reference only: mm [in.])

600-128-C24

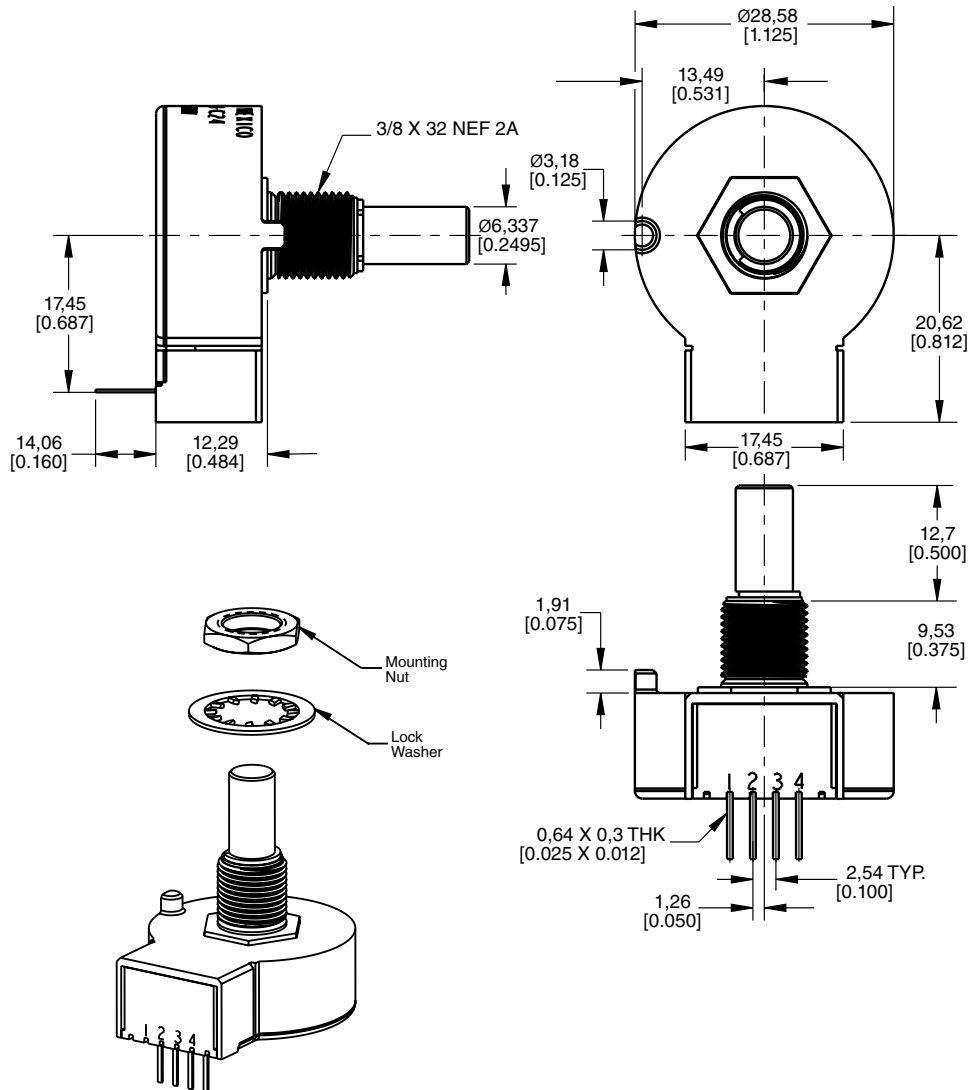

Optical Encoders, 600 Series

Figure 1. Mounting Dimensions (continued)

600-128-B66

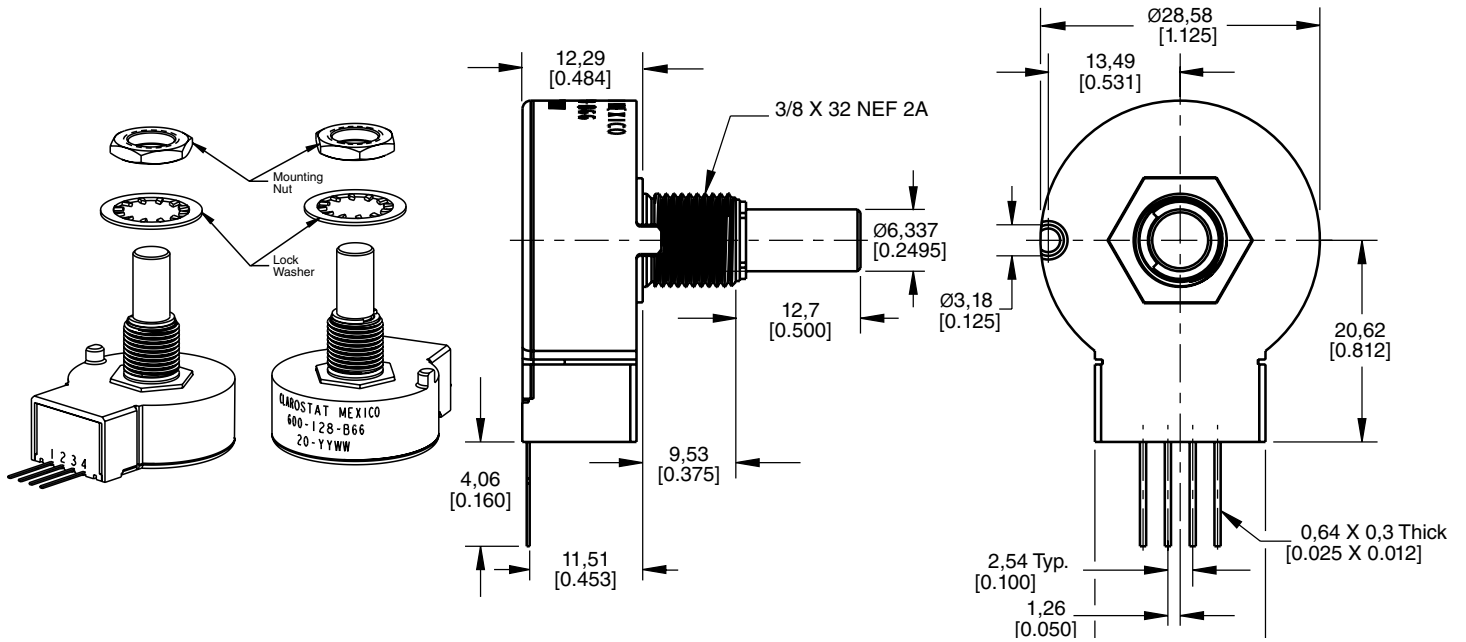

600-128-CBL

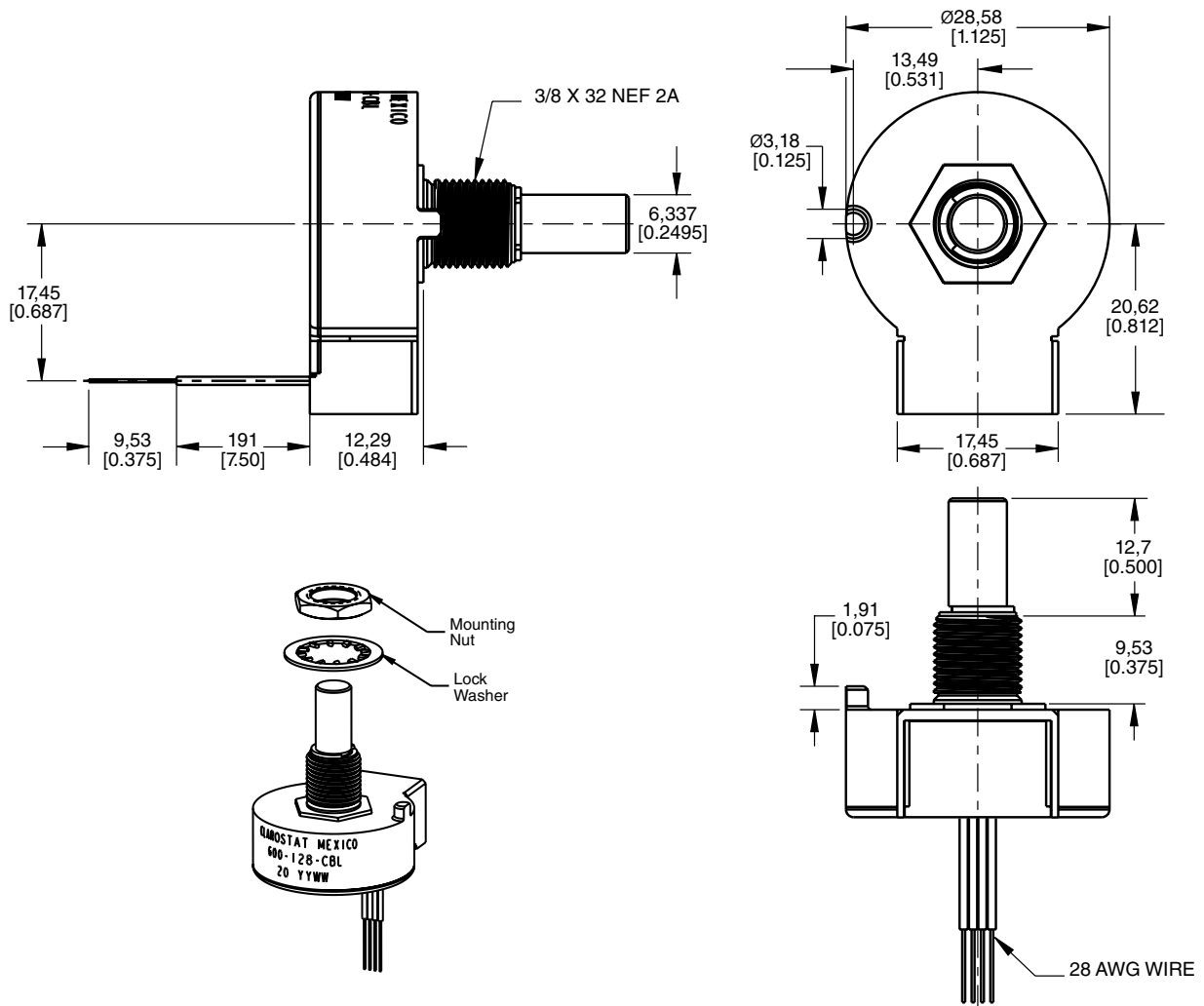

Optical Encoders, 600 Series

Figure 1. Mounting Dimensions (continued)

600-128-CN1

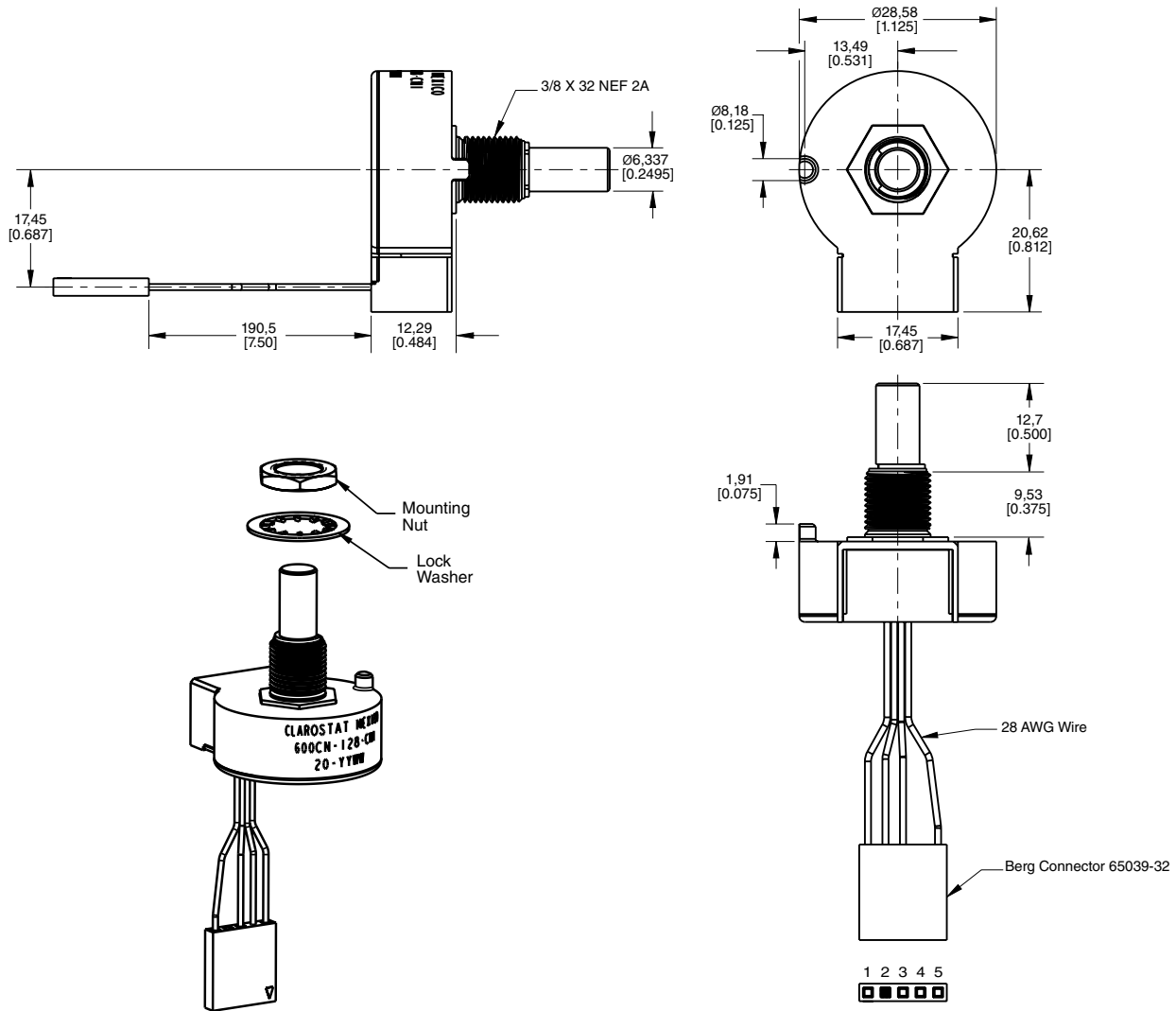

Figure 2. Mounting Hardware

Mounting Nut

3/8 in x 32



Lock Washer



Optical Encoders, 600 Series

Figure 3. Output Waveform

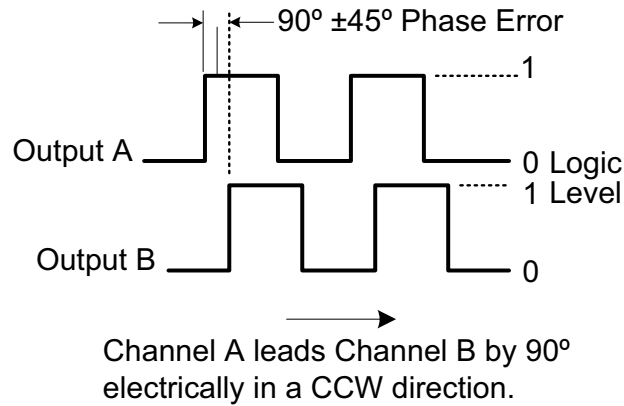

Figure 4. Block Diagram

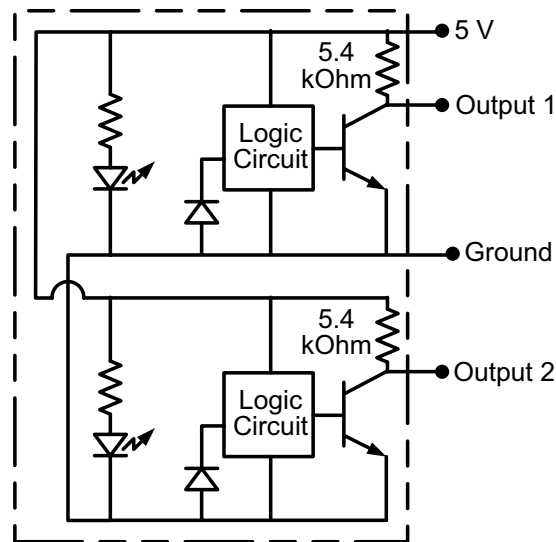

Table 4. Order Guide

Catalog Listing	Description
600-128-C24	600 Series optical encoder, PC terminal type C-24, vertical mounting, mounting hardware included
600-128-B66	600 Series optical encoder, PC terminal type B-66, horizontal mounting, mounting hardware included
600-128-CBL	600 Series optical encoder, 190,5 mm [7.5 in] cable, mounting hardware included
600-128-CN1	600 Series optical encoder, 190,5 mm [7.5 in] cable/connector, mounting hardware included

ADDITIONAL INFORMATION

The following associated literature is available at sensing.honeywell.com:

- Product Range Guide
- Product Line Guide
- Installation Instructions

Find out more

Honeywell serves its customers through a worldwide network of sales offices, representatives and distributors. For application assistance, current specifications, pricing or name of the nearest Authorized Distributor, contact your local sales office.

To learn more about Honeywell's sensing and control products, call **+1-815-235-6847** or **1-800-537-6945**, visit **sensing.honeywell.com**, or e-mail inquiries to **info.sc@honeywell.com**

Sensing and Control
Honeywell
1985 Douglas Drive North
Golden Valley, MN 55422
honeywell.com

⚠ WARNING

PERSONAL INJURY

DO NOT USE these products as safety or emergency stop devices or in any other application where failure of the product could result in personal injury.

Failure to comply with these instructions could result in death or serious injury.

⚠ WARNING

MISUSE OF DOCUMENTATION

- The information presented in this product sheet is for reference only. Do not use this document as a product installation guide.
- Complete installation, operation, and maintenance information is provided in the instructions supplied with each product.

Failure to comply with these instructions could result in death or serious injury.

WARRANTY/REMEDY

Honeywell warrants goods of its manufacture as being free of defective materials and faulty workmanship. Honeywell's standard product warranty applies unless agreed to otherwise by Honeywell in writing; please refer to your order acknowledgement or consult your local sales office for specific warranty details. If warranted goods are returned to Honeywell during the period of coverage, Honeywell will repair or replace, at its option, without charge those items it finds defective. **The foregoing is buyer's sole remedy and is in lieu of all other warranties, expressed or implied, including those of merchantability and fitness for a particular purpose. In no event shall Honeywell be liable for consequential, special, or indirect damages.**

While we provide application assistance personally, through our literature and the Honeywell website, it is up to the customer to determine the suitability of the product in the application.

Specifications may change without notice. The information we supply is believed to be accurate and reliable as of this printing. However, we assume no responsibility for its use.

Honeywell