



Chipsmall Limited consists of a professional team with an average of over 10 year of expertise in the distribution of electronic components. Based in Hongkong, we have already established firm and mutual-benefit business relationships with customers from,Europe,America and south Asia,supplying obsolete and hard-to-find components to meet their specific needs.

With the principle of “Quality Parts,Customers Priority,Honest Operation,and Considerate Service”,our business mainly focus on the distribution of electronic components. Line cards we deal with include Microchip,ALPS,ROHM,Xilinx,Pulse,ON,Everlight and Freescale. Main products comprise IC,Modules,Potentiometer,IC Socket,Relay,Connector.Our parts cover such applications as commercial,industrial, and automotives areas.

We are looking forward to setting up business relationship with you and hope to provide you with the best service and solution. Let us make a better world for our industry!



Contact us

Tel: +86-755-8981 8866 Fax: +86-755-8427 6832

Email & Skype: info@chipsmall.com Web: www.chipsmall.com

Address: A1208, Overseas Decoration Building, #122 Zhenhua RD., Futian, Shenzhen, China



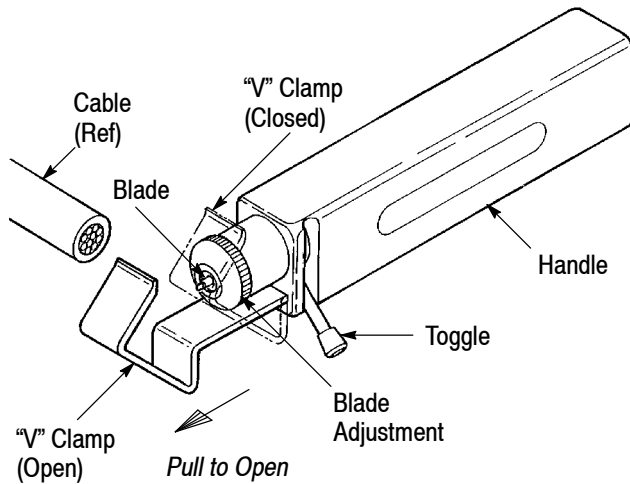

Figure 1

1. INTRODUCTION

NOTE



Dimensions in this instruction sheet are in millimeters [with inches in brackets]. Figures are not drawn to scale.

Cable Stripper/Slitter 606700-1 (Model CS-1) is designed to strip insulation from electrical cable having an outside diameter from 4.57 to 25.4 mm [.180 to 1.0 in.] (for example, battery cable up to size 4/0 AWG). This instruction sheet covers tool operating procedure and sharpening and replacement of the blade.

NOTE



This tool will not strip cable having cross-linked insulation.

Read these instructions thoroughly before using this tool.

Reasons for reissue of this instruction sheet are provided in Section 7, REVISION SUMMARY.

2. DESCRIPTION

This tool consists of a handle and a blade. The handle features a toggle used to rotate the blade, a blade adjustment used to adjust the length of exposed part of the blade, and "V" clamp used to hold the cable during stripping. The end of the "V" clamp has a knife edge to pry open the cable insulation. A replacement blade is held inside the handle.

3. USING THE TOOL

Practice the following steps on scrap cable lengths first.

1. Open the "V" clamp, and place the cable under the "V" clamp. Close the "V" clamp. See Figure 1.
2. Adjust the blade as shown in Figure 2. DO NOT set the blade too deep.

CAUTION



The blade will be damaged if it is set deep enough to nick the conductors.

Adjusting the Blade

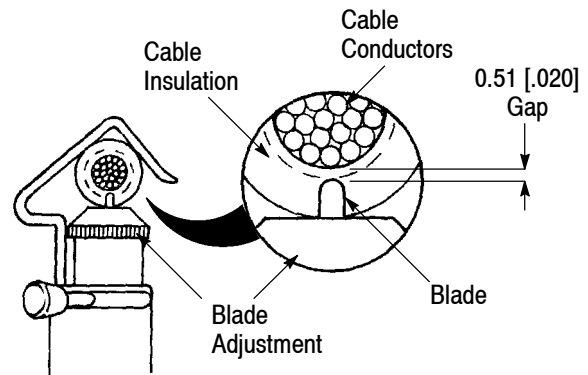

Figure 2

3. Slowly rotate the tool *clockwise* several times while pressing on the "V" clamp.
4. Using the toggle, rotate the blade 90°. While maintaining pressure, rock the tool longitudinally off of the cable.
5. Using the knife on the edge of the "V" clamp, separate the cable insulation from the conductors, and remove the insulation.
6. Inspect the cable for nicked strands. Re-adjust the blade if necessary.

4. SHARPENING OR REPLACING THE BLADE

1. Hold the tool with the "V" clamp open (see Figure 3).
2. Unscrew the blade adjustment; remove it from the handle, and retain.
3. Remove the spring and washer, and rotate the blade. Remove the blade. Retain these parts.

4. Sharpen the blade using an oil stone or fine grit grinding wheel — or — to obtain the replacement blade, pull the slotted pin (located at the base of the handle), stretching the spring; then immediately rotate the pin 90° exposing a small hole for blade access.



Wear safety glasses when using power tools.

5. Hold the “V” clamp open, and insert the blade into the slot at bottom of the well.
6. Install the washer and spring, and position the threads of the blade adjustment into the well.
7. Release the “V” clamp.
8. Screw the blade adjustment into the well until the blade tip appears. Loosen the blade adjustment by a half turn.

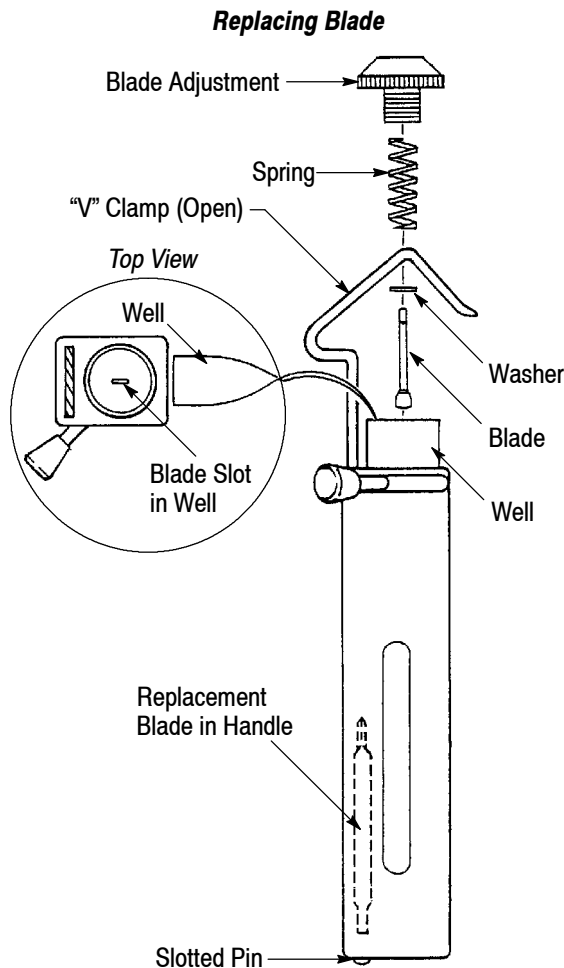

Figure 3

5. MAINTENANCE AND INSPECTION

To ensure proper operation, the tool and blade should conform to the dimensions provided in Figure 4. It is recommended that the tool be inspected immediately on its arrival and at regularly scheduled intervals.

Clean the tool using a soft, lint-free cloth. Store the tool in a clean, dry place.

Tool Dimensions

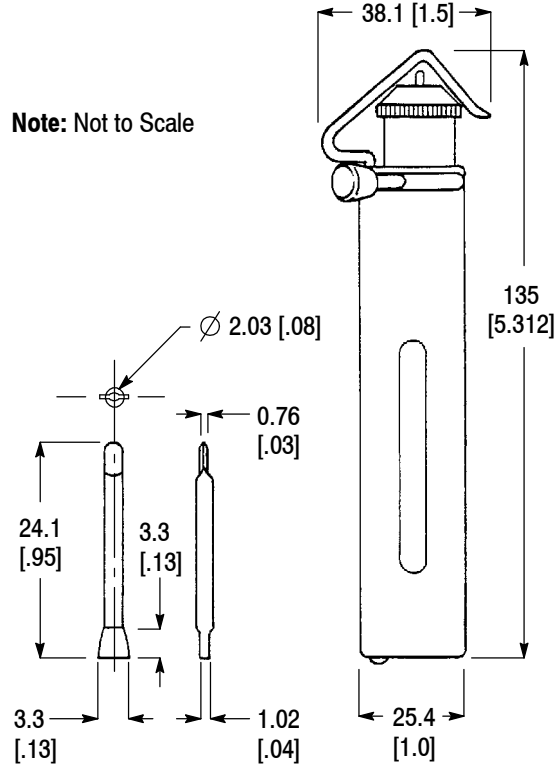

Note: Not to Scale

Figure 4

6. REPLACEMENT AND REPAIR

Order additional tools through your representative, or call 1-800-526-5142, or send a facsimile of your purchase order to 717-986-7605, or write to:

CUSTOMER SERVICE (038-035)
 TYCO ELECTRONICS CORPORATION
 PO BOX 3608
 HARRISBURG PA 17105-3608

7. REVISION SUMMARY

Revisions to this instruction sheet include:

- Updated document to corporate requirements
- New logo