



Chipsmall Limited consists of a professional team with an average of over 10 year of expertise in the distribution of electronic components. Based in Hongkong, we have already established firm and mutual-benefit business relationships with customers from,Europe,America and south Asia,supplying obsolete and hard-to-find components to meet their specific needs.

With the principle of “Quality Parts,Customers Priority,Honest Operation,and Considerate Service”,our business mainly focus on the distribution of electronic components. Line cards we deal with include Microchip,ALPS,ROHM,Xilinx,Pulse,ON,Everlight and Freescale. Main products comprise IC,Modules,Potentiometer,IC Socket,Relay,Connector.Our parts cover such applications as commercial,industrial, and automotives areas.

We are looking forward to setting up business relationship with you and hope to provide you with the best service and solution. Let us make a better world for our industry!



## Contact us

Tel: +86-755-8981 8866 Fax: +86-755-8427 6832

Email & Skype: info@chipsmall.com Web: www.chipsmall.com

Address: A1208, Overseas Decoration Building, #122 Zhenhua RD., Futian, Shenzhen, China



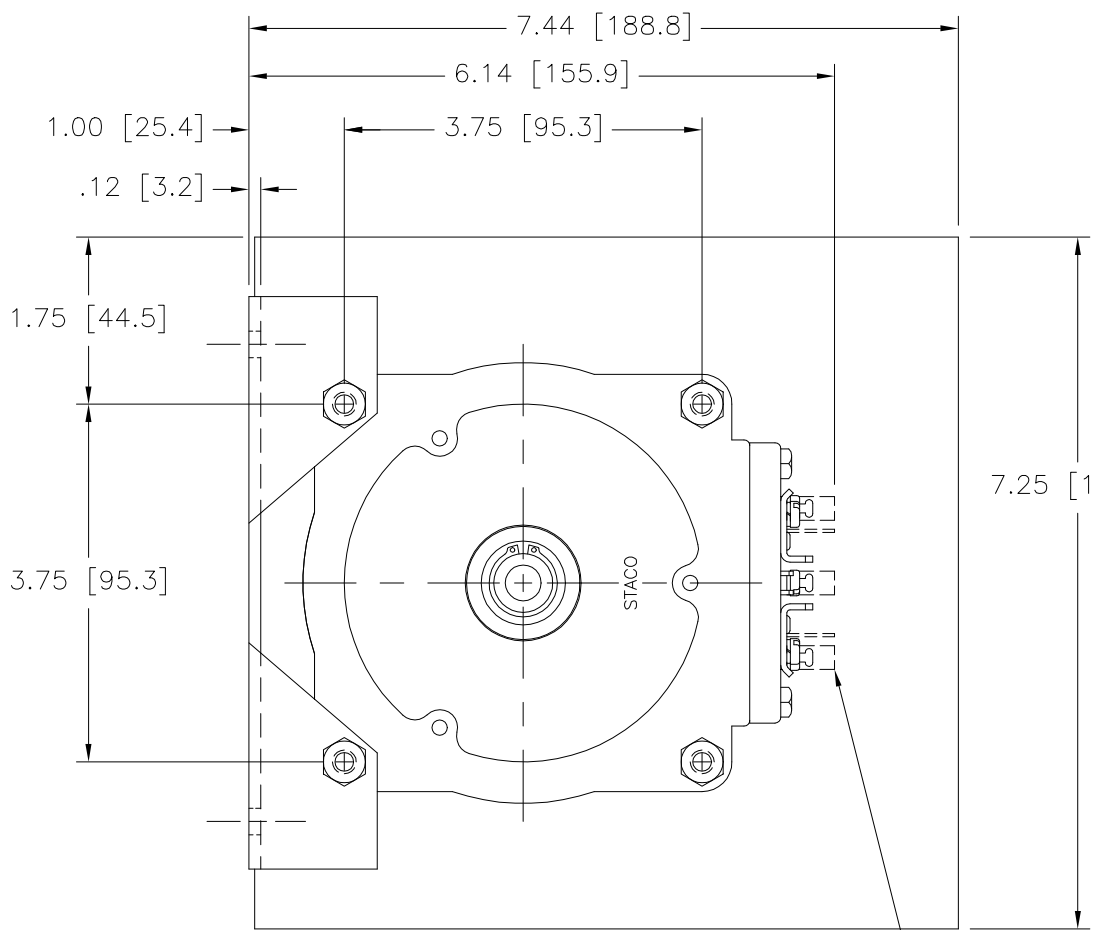

OPTIONAL TERMINALS FOR PUSH ON OR SOLDER CONNECTIONS (.032 X .250) [0.8 X 6.4]

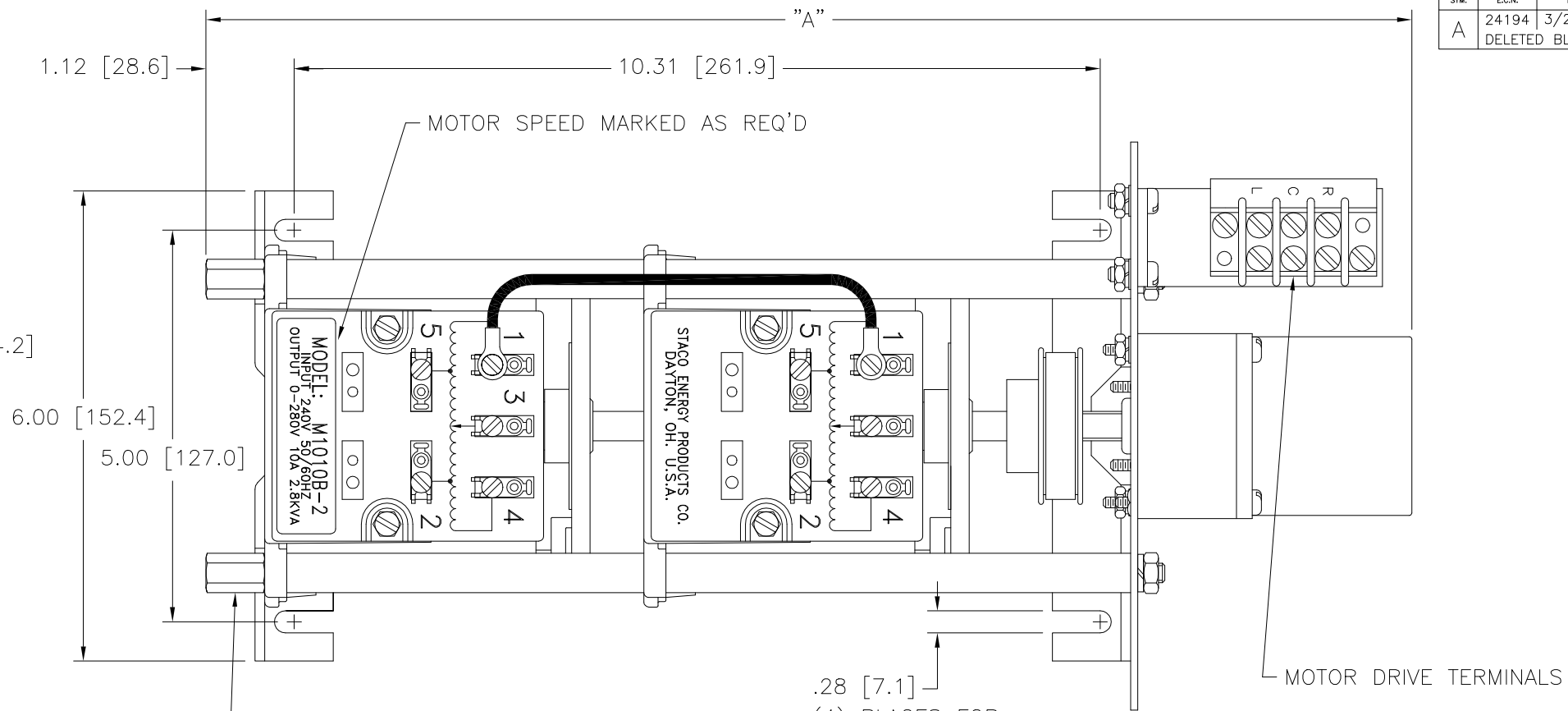

(4) STANDOFFS TAPPED 1/4-28 X .38 [9.5] DEEP FOR MOUNTING BOLTS

(4) PLACES FOR CUSTOMER MOUNTING

- + MOTOR DRIVEN UNITS USE TERMINAL CONNECTIONS FOR CCW INCREASING VOLTAGE, AS VIEWED FROM BASE END.
- π IF GANGED UNITS ARE USED IN A SYSTEM THAT ORDINARILY HAS A COMMON NEUTRAL OR GROUND BETWEEN SOURCE AND LOAD, THE NEUTRAL OR GROUND MUST BE CONNECTED TO THE COMMON TERMINALS OF THE VARIABLE TRANSFORMER ASSEMBLY. IF THE SYSTEM HAS NO NEUTRAL, THE LOAD MUST BE BALANCED OR THE TRANSFORMER WILL BE DAMAGED.
- JUMPER PROVIDED IN STANDARD COMMON POSITION AND SHOULD BE MOVED OR REMOVED AS REQUIRED.
- ++ LINE TO LINE VOLTAGE.

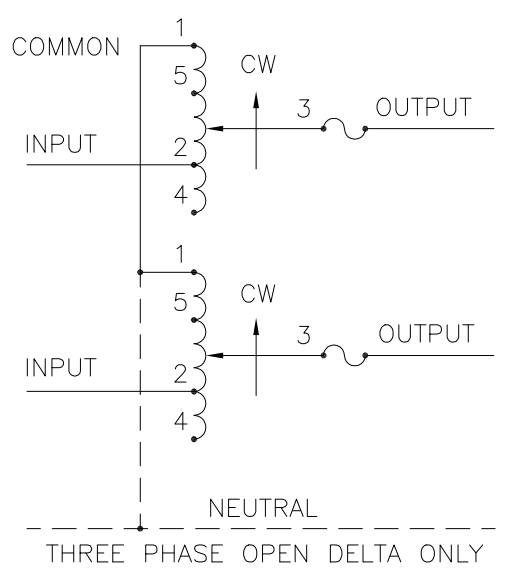

SCHEMATIC  
(FUSE RECOMMENDED BUT NOT SUPPLIED)

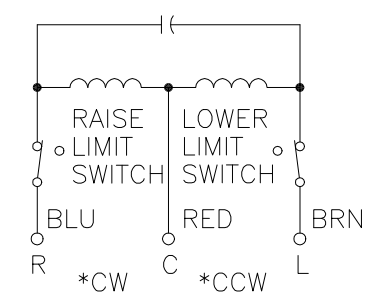

MOTOR CIRCUIT  
 120V, 50/60 HZ  
 \* ROTATION AS VIEWED FROM MOTOR END  
 MOTOR SPEED: SEE CHART

WIRING	INPUT		OUTPUT				SHAFT ROTATION TO INCREASE VOLTAGE	TERMINAL CONNECTIONS			
	VOLTS	HERTZ	VOLTS	CONSTANT CURRENT LOAD		CONSTANT IMPEDANCE LOAD		FOR INCREASING VOLTAGE AS VIEWED FROM BASE END +			
				MAX. AMPS	MAX. KVA	MAX. AMPS		MAX. KVA	INPUT	JUMPER ■	OUTPUT
SINGLE PHASE SERIES	240	50/60	0-240	10	2.4	13	3.12	CW	1-1	4-4	3-3
			0-280	10	2.8	—	—	CCW	4-4	1-1	3-3
	120	50/60	0-120	10	2.08	13	2.70	CW	5-5	4-4	3-3
			0-140	10	2.42	—	—	CCW	2-2	1-1	3-3
THREE PHASE OPEN DELTA π	120	50/60	0-120	10	2.08	13	2.70	CW	1-4-1	4-4	3-4-3
			0-140	10	2.42	—	—	CCW	4-1-4	1-1	3-1-3
	++	50/60	0-120	10	2.08	13	2.70	CW	5-4-5	4-4	3-4-3
			0-140	10	2.42	—	—	CCW	2-1-2	1-1	3-1-3

SPEED (SECONDS)	MODEL NUMBER	DIM "A"
5	5M1010B-2	15.40 [391.2]
15	15M1010B-2	15.40 [391.2]
30	30M1010B-2	15.79 [401.1]
60	60M1010B-2	15.79 [401.1]

UNLESS OTHERWISE SPECIFIED, TOLERANCE IS # DECIMALS Holes .002 ANGLES 1° DRAFT 1-1/2° XX .005 .005

MATERIAL: ALL DIMENSIONS APPLY AFTER PLATING

TITLE: SPEC. CONTROL DRAWING  
 MOTORIZED VARIABLE XFMR  
 MODEL: M1010B-2

DRAWN BY: S.A. SMITH DATE: 9/19/97 DO NOT SCALE DWG. CUSTOMER APPROVAL: DATE

CHECKER: DATE WEIGHT APPROX. 29 LBS CODE IDENT. NO. 83008 DWG. NO. 031-1740

ENGINEER: DATE SCALE 1=1 SHEET 1 OF 1

