



Chipsmall Limited consists of a professional team with an average of over 10 year of expertise in the distribution of electronic components. Based in Hongkong, we have already established firm and mutual-benefit business relationships with customers from,Europe,America and south Asia,supplying obsolete and hard-to-find components to meet their specific needs.

With the principle of "Quality Parts,Customers Priority,Honest Operation,and Considerate Service",our business mainly focus on the distribution of electronic components. Line cards we deal with include Microchip,ALPS,ROHM,Xilinx,Pulse,ON,Everlight and Freescale. Main products comprise IC,Modules,Potentiometer,IC Socket,Relay,Connector.Our parts cover such applications as commercial,industrial, and automotives areas.

We are looking forward to setting up business relationship with you and hope to provide you with the best service and solution. Let us make a better world for our industry!



Contact us

Tel: +86-755-8981 8866 Fax: +86-755-8427 6832

Email & Skype: info@chipsmall.com Web: www.chipsmall.com

Address: A1208, Overseas Decoration Building, #122 Zhenhua RD., Futian, Shenzhen, China





ASTRO TOOL CORP.

CONNECTOR ASSEMBLY TOOLING CYCLE CONTROLLED C-FRAME STYLE CRIMP TOOL 612648 (M22910/7-1) AND ASSOCIATED TYPES

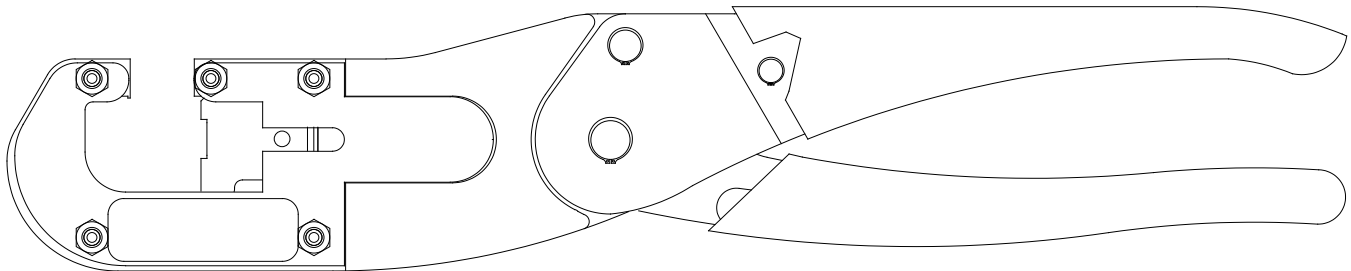

INSTRUCTIONS FOR USE OF 612648 HEX POP-IN DIE CRIMP TOOL

GENERAL:

The Astro Tool Corp. Hex Pop-in Die Crimping Tool is a cycle controlled, manually operated, C-frame tool for crimping shield terminating ferrules, RF connector fittings, and other terminations requiring an open frame crimp tool.

There is only one set up operation required - installing the required die set. Die sets are available in single, double and triple hex cavities. Special form crimps are also obtainable, consult the factory for details.

The Tool's precision cycle control mechanism assures a high quality, repeatable crimp. The in-line action of the dies and toggle mechanism reduces the compression force required to complete the crimp.

For long life and optimum performance, this tool should be kept clean and handled with the care of any other precision device.

a. Open and close the tool several times and observe the precision cycle-control mechanism. Note that the tool cannot be opened without completing its cycle.

b. Identify the parts in figure #1:

1. Ratchet Handle
2. Movable Die Nest
3. Housing Cleat
4. Stationary Die Retaining Detent

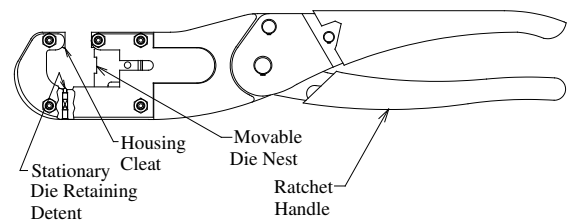

Figure #1

OPERATION

c. Die Installation

1. The tool must be in the fully open position as shown in figure #2.

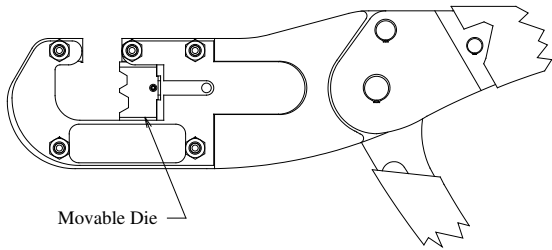

Figure # 2

2. Locate the Movable Pop-in Die and insert the die post into the die nest. Note the off-center die post. The Movable Pop-in Die can only be inserted in one direction. See figure # 2

NOTE: The Movable Pop-in Die must be installed first.

3. Locate the Stationary Pop-in Die and engage the flat end of the Die with the housing cleat. Rotate the die in a clock-wise direction to engage it with the Stationary Die Retaining Detent, see figure #3. Observe that the Stationary Pop-in Die is installed parallel to the side plates and that it is not skewed in any way.

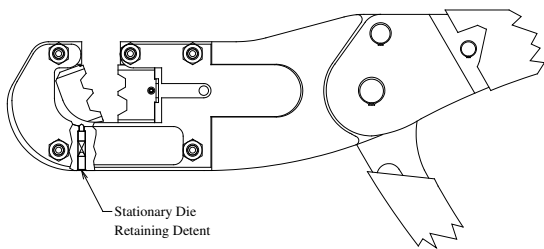

Figure #3

CAUTION:

VERIFY THAT THE STATIONARY DIE IS INSTALLED CORRECTLY. IMPROPER INSTALLATION WILL RESULT IN DAMAGE TO THE TOOL OR THE DIE SET.

4. Cycle the tool to set the die.

d. Crimping Operation

1. The tool must be in the fully open position. Insert the prepared connector through the tool opening and place in the appropriate cavity. For RF connector fittings use the die face as a locational stop. For shield terminations locate the crimp by eye.

2. Squeeze the handles together until the positive stop is reached. The tool will release and return to the fully open position.

3. Remove the crimped termination.

e. Die Removal

1. The tool must be in the fully open position.

2. To remove the Stationary Pop-in Die, locate the DRT7. Insert the DRT7 into the hole in the top of the tool, as shown in figure #4, and tap lightly on the end indicated. The Stationary Pop-in Die will drop from the tool.

NOTE: Always remove the Stationary Pop-in Die First.

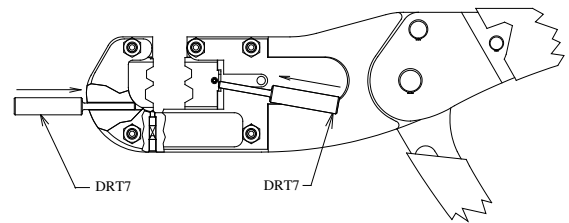

Figure #4

3. To remove the Movable Pop-in Die, position the DRT7 as shown in figure #4, and tap upward lightly to release the die.

f. Tool Calibration

1. The hand pressure required to cycle the tool with a set of dies in it should be set at 20-50 lb. Astro has the AT903 spring tester available for this purpose.

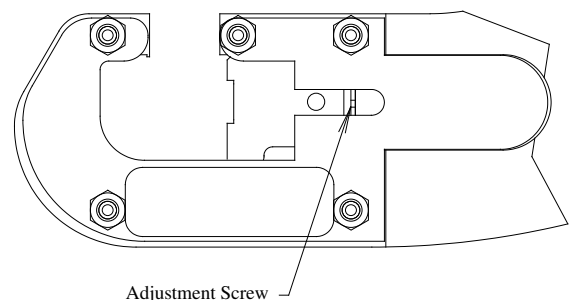

Figure #5

2. If calibration of the hand pressure is required, locate the adjustment screw in the Movable Die Nest by closing the tool. Using a flat blade screwdriver, rotate the screw to the right to decrease the pressure, to the left to increase the hand pressure. See figure # 5

3. When hand pressure calibration is achieved, lock screw in place using an appropriate NON-PERMANENT sealant.

g. Tool Gaging

1. Astro Tool Corp. manufactures flat GO-NO GO pin assemblies for many of the dies used by the 612648 crimp tool. Contact the factory for your specific requirements.

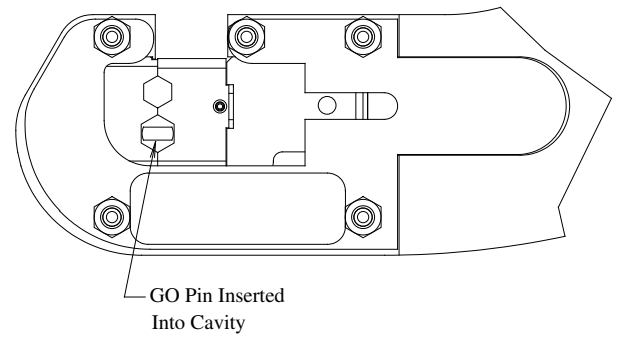

Figure #6

2. With a die set properly installed, cycle the tool into the fully closed position. Insert the appropriate GO sized flat pin into the hex cavity. It shall freely enter the hex cavity. See figure # 6. Remove the GO pin and attempt insert the NO-GO pin into the hex cavity. It should not enter the cavity.

DO NOT CRIMP GAGE, TOOL DAMAGE WILL RESULT.

**ASTRO TOOL CORP. MANUFACTURERS OF INSTALLING, REMOVAL AND CRIMP TOOLS
21615 S.W. T-V HWY. • BEAVERTON OREGON 97003 • 503-642-9853 • FAX 503-591-7766
CONNECTOR ASSEMBLY TOOLING**