



Chipsmall Limited consists of a professional team with an average of over 10 year of expertise in the distribution of electronic components. Based in Hongkong, we have already established firm and mutual-benefit business relationships with customers from,Europe,America and south Asia,supplying obsolete and hard-to-find components to meet their specific needs.

With the principle of "Quality Parts,Customers Priority,Honest Operation,and Considerate Service",our business mainly focus on the distribution of electronic components. Line cards we deal with include Microchip,ALPS,ROHM,Xilinx,Pulse,ON,Everlight and Freescale. Main products comprise IC,Modules,Potentiometer,IC Socket,Relay,Connector.Our parts cover such applications as commercial,industrial, and automotives areas.

We are looking forward to setting up business relationship with you and hope to provide you with the best service and solution. Let us make a better world for our industry!



Contact us

Tel: +86-755-8981 8866 Fax: +86-755-8427 6832

Email & Skype: info@chipsmall.com Web: www.chipsmall.com

Address: A1208, Overseas Decoration Building, #122 Zhenhua RD., Futian, Shenzhen, China



PRODUCT NO.
61573-150CA

Tous droits strictement réservés. Reproduction ou communication à des tiers sans autorisation écrite du propriétaire. Droits de reproduction BERG ELECTRONICS by

All rights strictly reserved. Reproduction or issue to third parties in any form without written authority from the proprietor. Copyright BERG ELECTRONICS by

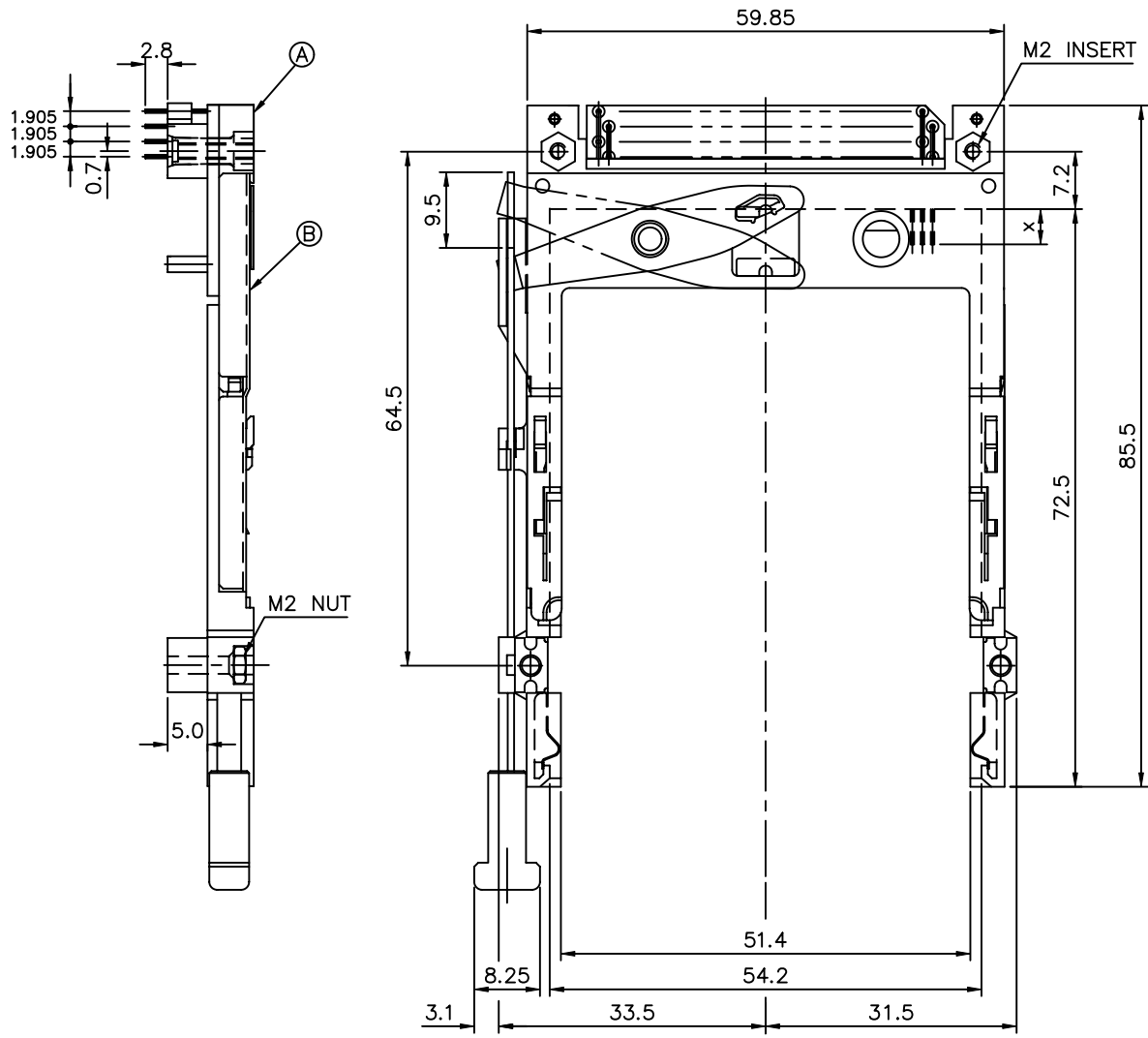

- NOTES:
- EJECT FORCE : 3.5 Kg MAX.
 - EJECT TRAVEL: 8.0mm
 - MATERIAL
 - PART (A) (HEADER ASS'Y)
PLASTIC : HOUSING ...LCP UL94V-0 BLACK
LOCATOR ...G.F. 6/6 NYLON UL94-VO BLACK
PIN : PHOSPHOR BRONZE
 - PART (B) (EJECT MECHANISM ASS'Y)
PLASTIC : GUIDE: POLYPHTHARAMID UL94V-0 BLACK
BUTTON: POLYPHTHARAMID UL94V-0 BLACK
PLATE : STAINLESS
EMI CONTACT: PHOSPHOR BRONZE
 - FINISH (PIN)
UNDER PLATING : 0.5 μm MIN. Ni
CONTACT AREA : 0.1 μm MIN. GOLD OVER 0.5 μm MIN. Pd-Ni
SOLDER TAIL : 2.5 μm MIN. Sn-Pb
 - DIM "X"

4.25±0.1	3.5±0.1	5.0±0.1
OTHERS	36,67	1,17,34,35,51,68

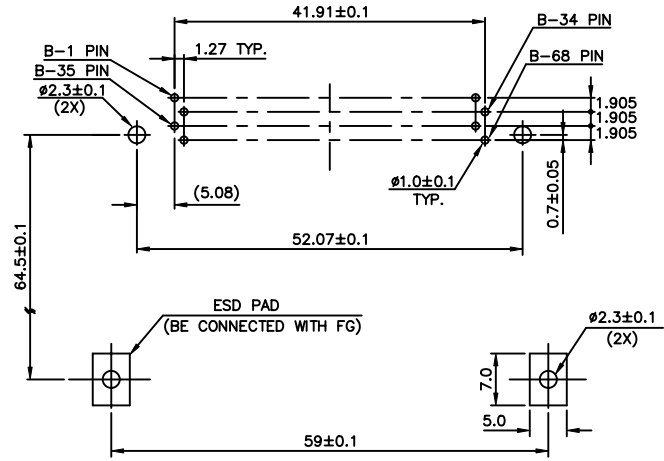

USE THE FOLLOWING P/N FOR OFFICIAL ORDERING

(B)	EJECT MECH ASS'Y	95627-15CA
(A)	HDR ASS'Y	92856-020
DESCRIPTION	P/N	

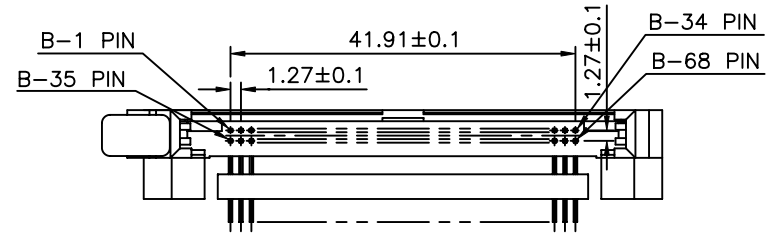

mat'l code		tolerance unless otherwise specified		CUSTOMER COPY		FCI ELECTRONICS	
rev.	ecn no.	dr	date	linear	±0.30	projection	title
B	T70083	C M	03/03/97				NARROW BODY FRONT EJECT
C	T70304	W L	07/20/97				TYPE 1/2/3 EJECTOR ASS'Y
D	T80430	W L	09/24/98	angles	± 2°		
E	T80516	W L	11/10/98	dr	SHIRLEY HSU	09/03/96	unit
F	T90015	W L	01/14/99	engr	JOSEPH HSIA	09/03/96	mm/inch
G	T90291	W L	08/05/99	chr	JOSEPH HSIA	09/03/96	scale
H	T00133	W L	05/04/00	appd	JENN TSAO	09/03/96	1.5:1
sheet	revision	H	G	G	G	G	G
index	sheet	1	2	3	4	5	6
				A3		61573	
				1 OF 9		TWN	

PRODUCT NO.
61573-600CA

Tous droits strictement réservés. Reproduction ou communication à des tiers sans autorisation écrite du propriétaire.
Droits de reproduction BERG ELECTRONICS by

All rights strictly reserved. Reproduction or issue to third parties in any form without the written authority from the proprietor.
Copyright BERG ELECTRONICS by

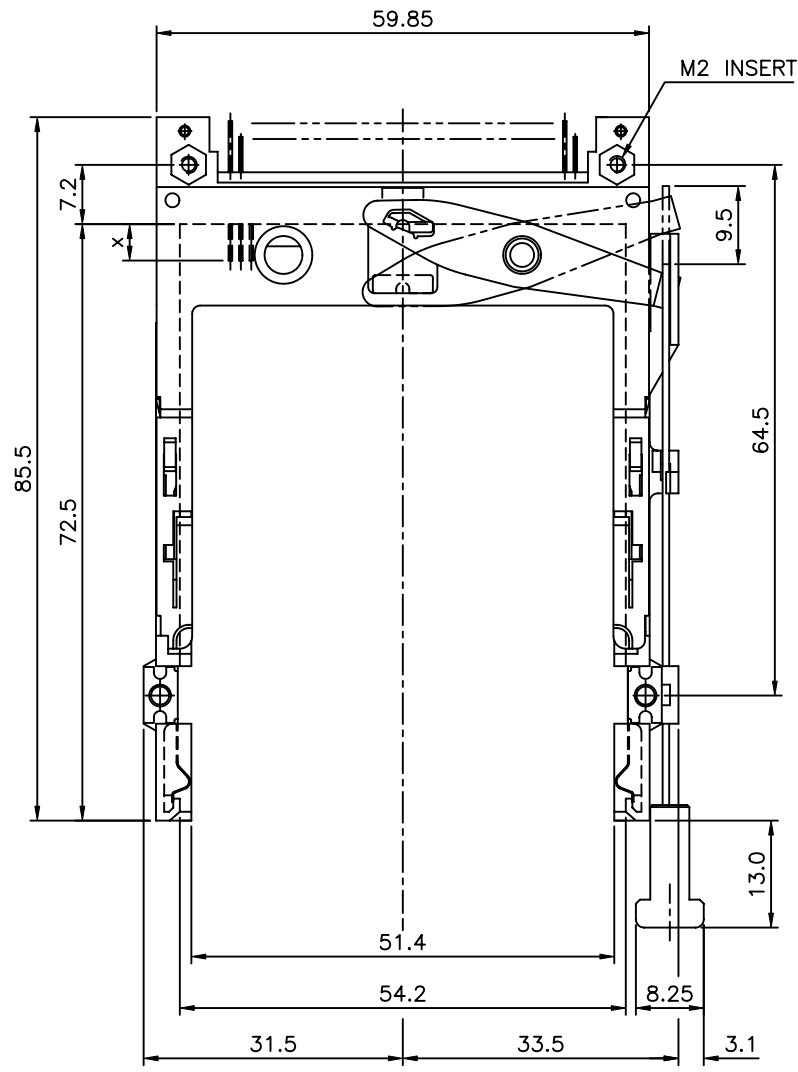
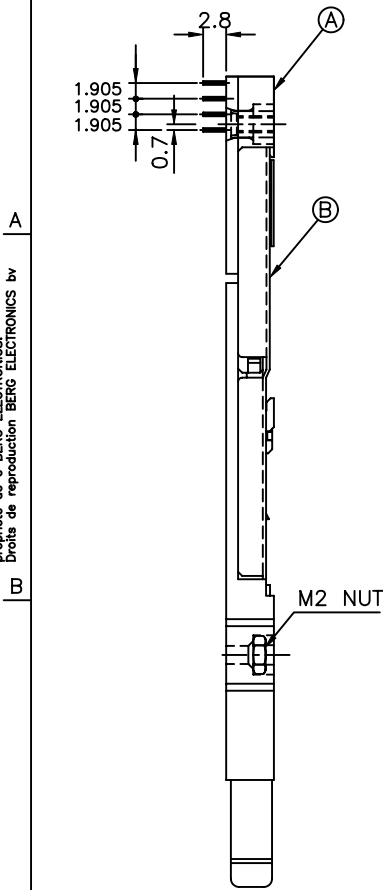

NOTES:

- EJECT FORCE : 3.5 Kg MAX.
- EJECT TRAVEL: 8.0mm
- MATERIAL
 - PART A (HEADER ASS'Y)
PLASTIC : HOUSING ...LCP UL94V-0 BLACK
PIN : PHOSPHOR BRONZE
 - PART B (EJECT MECHANISM ASS'Y)
PLASTIC : GUIDE: POLYPHTHARAMID UL94V-0 BLACK
BUTTON: POLYPHTHARAMID UL94V-0 BLACK
PLATE : STAINLESS
EMI CONTACT: PHOSPHOR BRONZE
- FINISH (PIN)
UNDER PLATING : 0.5 μm MIN. Ni
CONTACT AREA : 0.1 μm MIN. GOLD OVER 0.5 μm MIN. Pd-Ni
SOLDER TAIL : 2.5 μm MIN. Sn-Pb
- DIM "X"

4.25±0.1	3.5±0.1	5.0±0.1
OTHERS	36,67	1,17,34,35,51,68

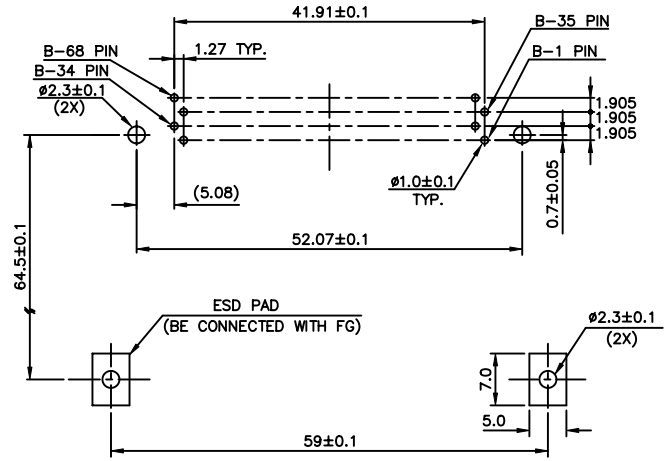

4 CARD INSERTION DIRECTION

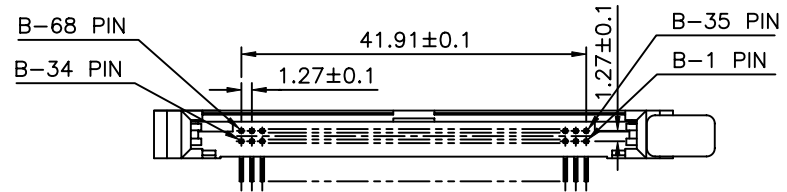

USE THE FOLLOWING P/N FOR OFFICIAL ORDERING

B	EJECT MECH ASS'Y	95627-00CA
A	HDR ASS'Y	92856-500
DESCRIPTION	P/N	

mat'l code		tolerance unless otherwise specified		CUSTOMER COPY	FCI ELECTRONICS	
rev.	ecn no.	dr	date	linear	±0.30	projection
G				angles	± 2°	title
				dr	SHIRLEY HSU 09/03/96	NARROW BODY FRONT EJECT TYPE 1/2/3 EJECTOR ASS'Y
				enr	JOSEPH HSIA 09/03/96	product family : PCMCIA
				chr	JOSEPH HSIA 09/03/96	code
				appd	JENN TSAO 09/03/96	TWN
sheet	revision			unit	mm/inch	size
index	sheet			scale	1.5:1	dwg no.
						61573
						2 OF

PRODUCT NO.
61573-500CA

Tous droits strictement réservés. Reproduction ou communication à des tiers sans autorisation écrite du propriétaire.
Droits de reproduction BERG ELECTRONICS by

All rights strictly reserved. Reproduction or issue to third parties in any form without the written authority from the proprietor.
Copyright BERG ELECTRONICS by

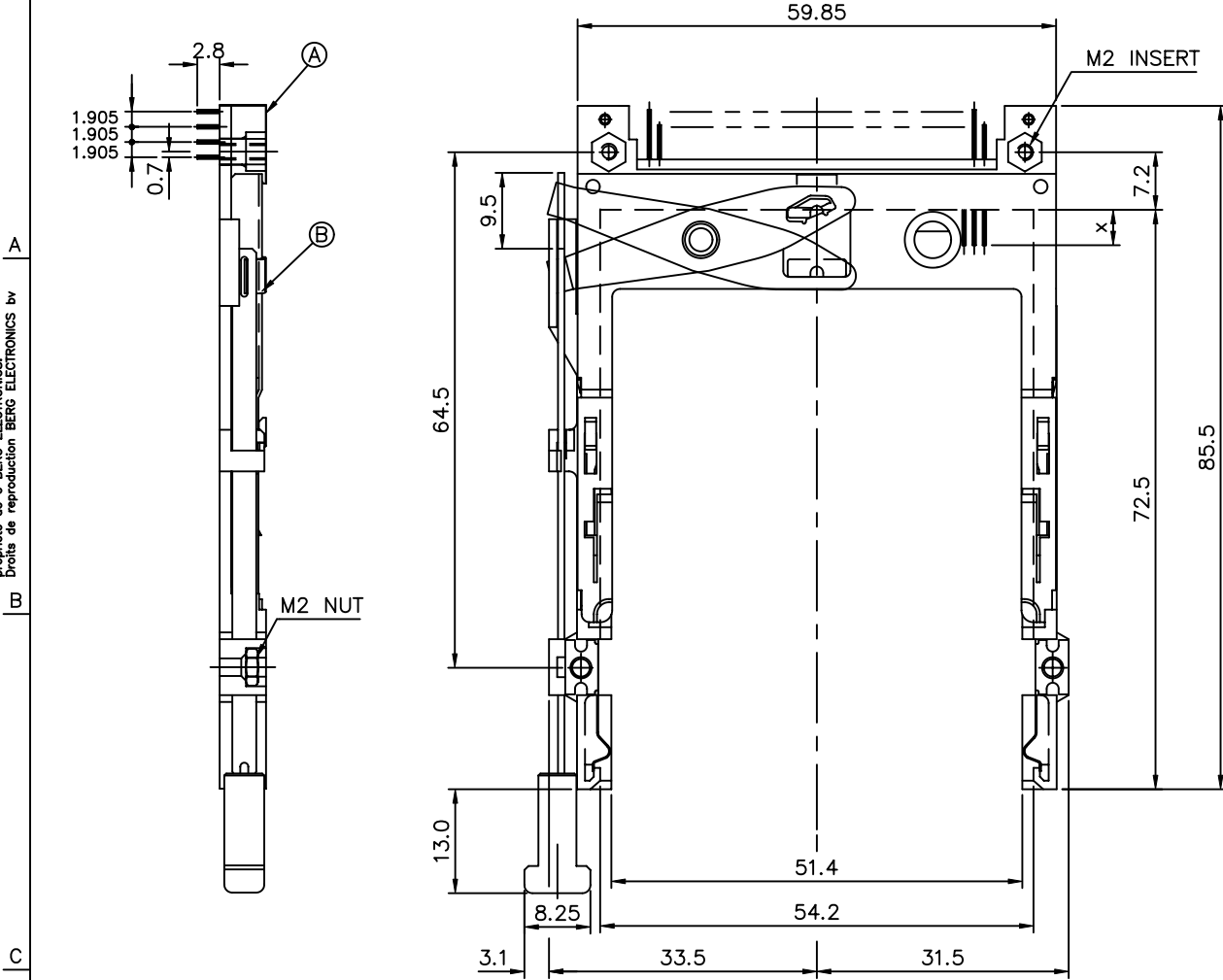

NOTES:

- EJECT FORCE : 3.5 Kg MAX.
- EJECT TRAVEL: 8.0mm
- MATERIAL
 - PART ① (HEADER ASS'Y)
PLASTIC : HOUSING ...LCP UL94V-0 BLACK
PIN : PHOSPHOR BRONZE
 - PART ② (EJECT MECHANISM ASS'Y)
PLASTIC : GUIDE: POLYPHTHARAMID UL94V-0 BLACK
: BUTTON: POLYPHTHARAMID UL94V-0 BLACK
PLATE : STAINLESS
EMI CONTACT: PHOSPHOR BRONZE
- FINISH (PIN)
UNDER PLATING : 0.5 um MIN. Ni
CONTACT AREA : 0.1 um MIN. GOLD OVER 0.5 um MIN. Pd-Ni
SOLDER TAIL : 2.5 um MIN. Sn-Pb
- DIM "X"

4.25±0.1	3.5±0.1	5.0±0.1
OTHERS	36,67	1,17,34,35,51,68

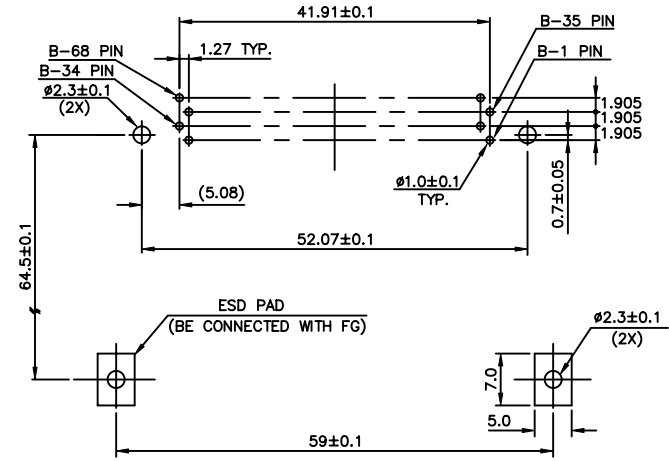

4 CARD INSERTION DIRECTION

USE THE FOLLOWING P/N FOR OFFICIAL ORDERING

②	EJECT MECH ASS'Y	95627-10CA
①	HDR ASS'Y	92856-500
DESCRIPTION	P/N	

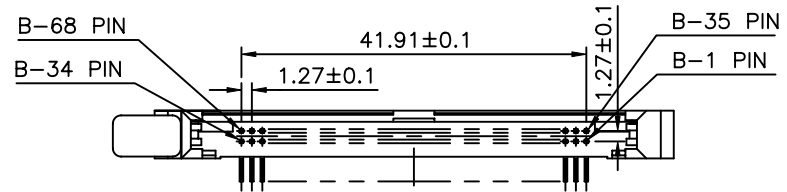

mat'l code		tolerance unless otherwise specified		CUSTOMER COPY	FCI ELECTRONICS	
rev.	ecn no.	dr	date	linear	±0.30	projection
G				angles	± 2°	title
				dr	SHIRLEY HSU 09/03/96	NARROW BODY FRONT EJECT TYPE 1/2/3 EJECTOR ASS'Y
				enr	JOSEPH HSIA 09/03/96	product family : PCMCIA
				chr	JOSEPH HSIA 09/03/96	code
				appd	JENN TSAO 09/03/96	TWN
						sheet
sheet	revision			unit	mm/inch	3 of
index	sheet			scale	1.5:1	
				size	A3	
				dwg no.	61573	

PRODUCT NO.
61573-000CA

Tous droits strictement réservés. Reproduction ou communication à des tiers sans autorisation écrite du propriétaire. Droits de reproduction BERG ELECTRONICS by

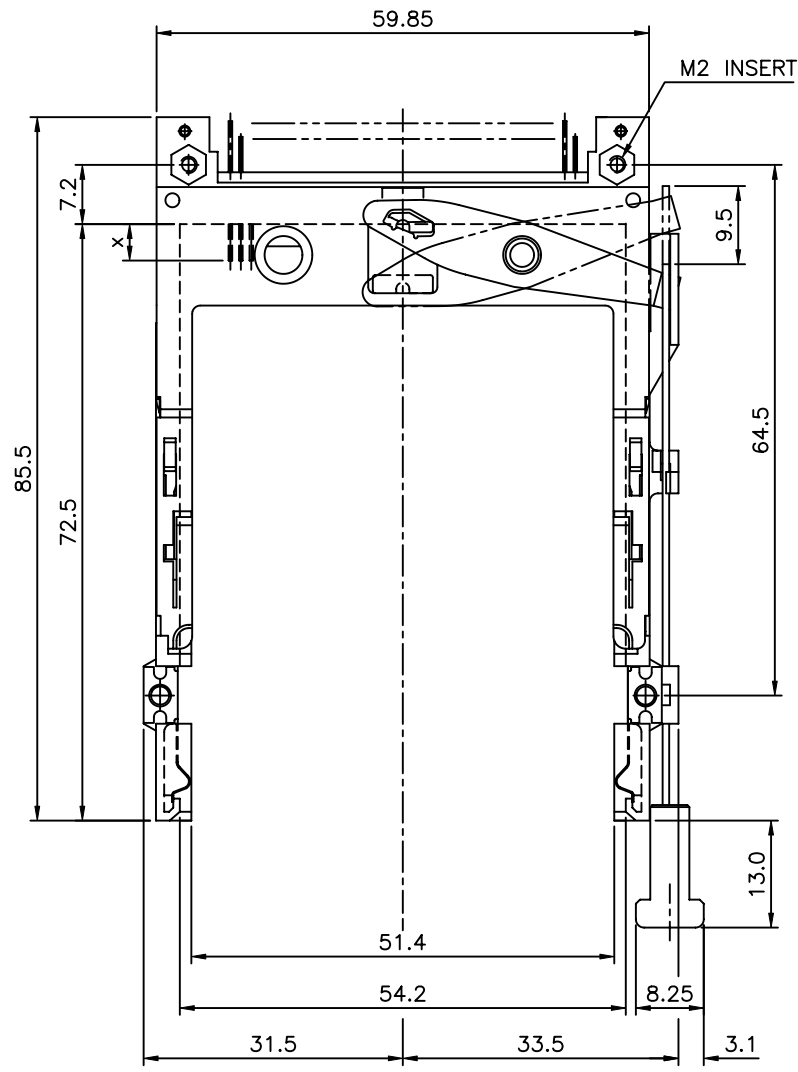
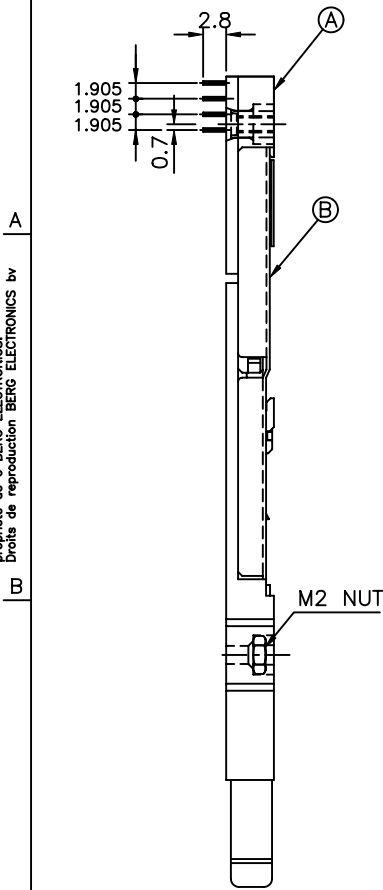

NOTES:

- EJECT FORCE : 3.5 Kg MAX.
- EJECT TRAVEL: 8.0mm
- MATERIAL
 - PART Ⓐ (HEADER ASS'Y)
PLASTIC : HOUSING ...LCP UL94V-0 BLACK
PIN : PHOSPHOR BRONZE
 - PART Ⓑ (EJECT MECHANISM ASS'Y)
PLASTIC : GUIDE: POLYPHTHARAMID UL94V-0 BLACK
: BUTTON: POLYPHTHARAMID UL94V-0 BLACK
PLATE : STAINLESS
EMI CONTACT: PHOSPHOR BRONZE
- FINISH (PIN)
UNDER PLATING : 0.5 um MIN. Ni
CONTACT AREA : 0.1 um MIN. GOLD OVER 0.5 um MIN. Pd-Ni
SOLDER TAIL : 2.5 um MIN. Sn-Pb
- DIM "X"

4.25±0.1	3.5±0.1	5.0±0.1
OTHERS	36,67	1,17,34,35,51,68

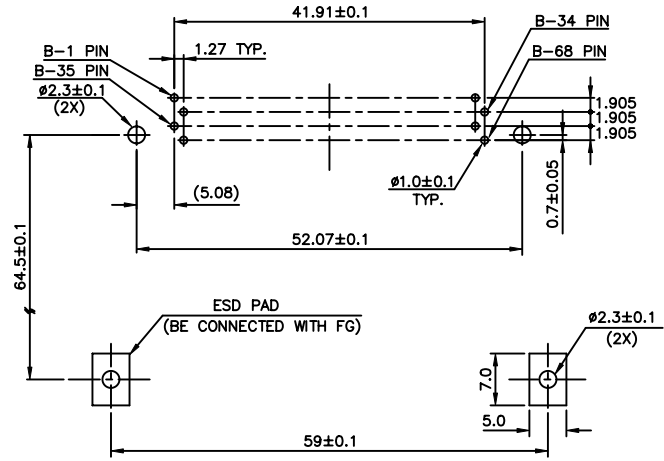

4 CARD INSERTION DIRECTION

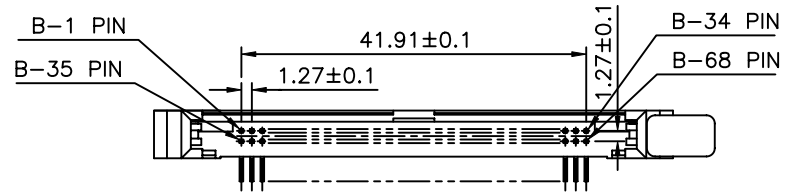

USE THE FOLLOWING P/N FOR OFFICIAL ORDERING

Ⓑ	EJECT MECH ASS'Y	95627-00CA
Ⓐ	HDR ASS'Y	92856-000
DESCRIPTION	P/N	

All rights strictly reserved. Reproduction or issue to third parties in any form without written authority from the proprietor. Property of BERG ELECTRONICS. Copyright BERG ELECTRONICS by

mat'l code		tolerance unless otherwise specified		CUSTOMER COPY	FCI ELECTRONICS	
rev.	ecn no.	dr	date	linear	projection	title
G				±0.30	⊕	NARROW BODY FRONT EJECT TYPE 1/2/3 EJECTOR ASS'Y
				angles ± 2°	unit	product family : PCMCIA
				dr WENDY CHEN 09/15/98	mm/inch	code
				enr JOSEPH HSIA 09/15/98	scale	TWN
				chr JOSEPH HSIA 09/15/98	1.5:1	sheet
				appd JENN TSAO 09/15/98	A3	5 of
sheet	revision					
index	sheet					

PRODUCT NO.
61573-050CA

Tous droits strictement réservés. Reproduction ou communication à des tiers sans autorisation écrite du propriétaire. Droits de reproduction BERG ELECTRONICS by
 All rights strictly reserved. Reproduction or issue to third parties in any form without the written authority from the proprietor. Property of BERG ELECTRONICS. Copyright BERG ELECTRONICS by

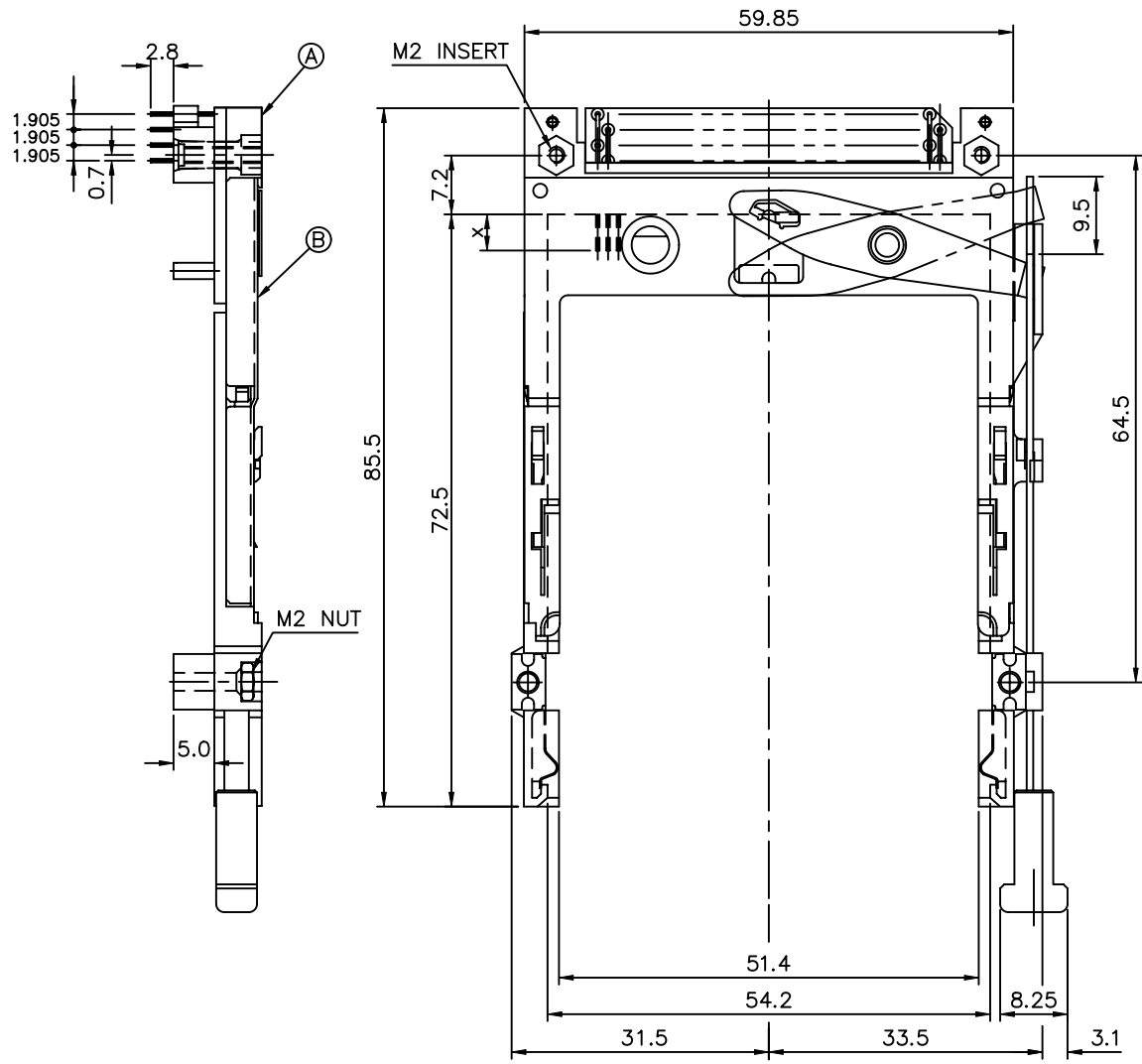

- NOTES:
- EJECT FORCE : 3.5 Kg MAX.
 - EJECT TRAVEL: 8.0mm
 - MATERIAL
 - PART A (HEADER ASS'Y)
 PLASTIC : HOUSING ...LCP UL94V-O BLACK
 : LOCATOR ...G.F. 6/6 NYLON UL94-VO BLACK
 PIN : PHOSPHOR BRONZE
 - PART B (EJECT MECHANISM ASS'Y)
 PLASTIC : GUIDE: POLYPHTHARAMID UL94V-O BLACK
 : BUTTON: POLYPHTHARAMID UL94V-O BLACK
 PLATE : STAINLESS
 EMI CONTACT: PHOSPHOR BRONZE
 - FINISH (PIN)
 UNDER PLATING : 0.5 μm MIN. Ni
 CONTACT AREA : 0.1 μm MIN. GOLD OVER 0.5 μm MIN. Pd-Ni
 SOLDER TAIL : 2.5 μm MIN. Sn-Pb
 - DIM "X"

4.25±0.1	3.5±0.1	5.0±0.1
OTHERS	36,67	1,17,34,35,51,68

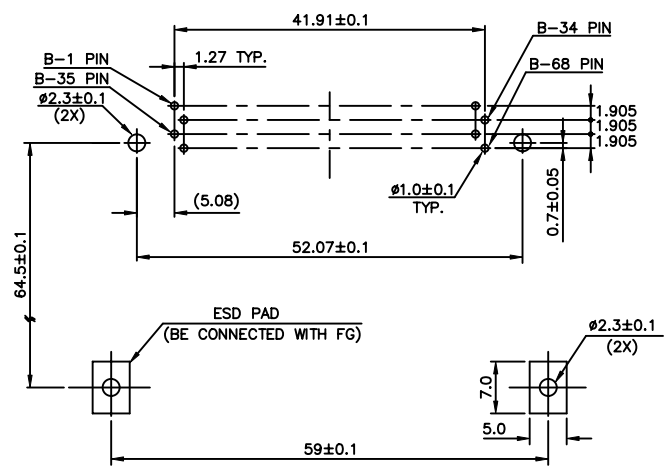

4 CARD INSERTION DIRECTION

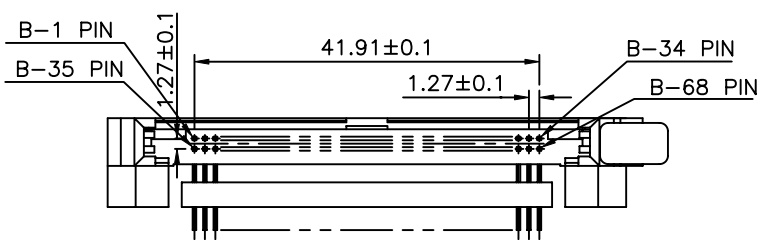

USE THE FOLLOWING P/N FOR OFFICIAL ORDERING

B	EJECT MECH ASS'Y	95627-05CA
A	HDR ASS'Y	92856-020
DESCRIPTION	P/N	

mat'l code		tolerance unless otherwise specified		CUSTOMER COPY	FCI ELECTRONICS	
rev.	ecn no.	dr	date	linear	±0.30	projection
G				angles	± 2°	title
				dr	WENDY CHEN 11/10/98	unit
				enr	JOSEPH HSIA 11/10/98	mm/inch
				chr	JOSEPH HSIA 11/10/98	scale
				appd	JENN TSAO 11/10/98	1.5:1
sheet		revision		product family : PCMCIA		code
index		sheet		size		TWN
				dwg no.		6 OF
				A3		61573

PRODUCT NO.
61573-040CA

Tous droits strictement réservés. Reproduction ou communication à des tiers interdite sans autorisation écrite du propriétaire.
 Property of BERG ELECTRONICS.
 Copyright BERG ELECTRONICS by

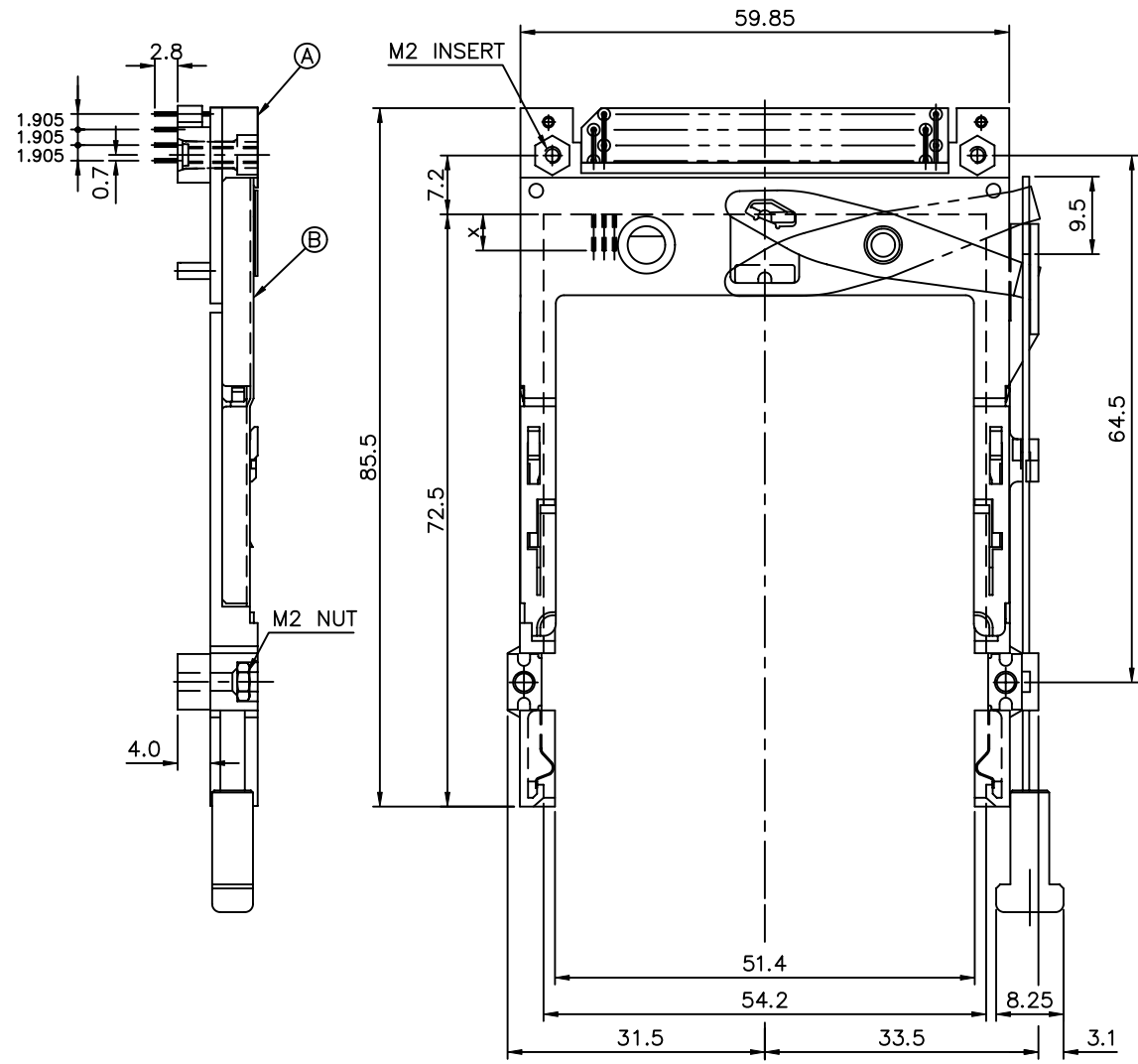

- NOTES:
- EJECT FORCE : 3.5 Kg MAX.
 - EJECT TRAVEL: 8.0mm
 - MATERIAL
 - PART (A) (HEADER ASS'Y)
 PLASTIC : HOUSING ...LCP UL94V-O BLACK
 : LOCATOR ...G.F. 6/6 NYLON UL94-VO BLACK
 PIN : PHOSPHOR BRONZE
 - PART (B) (EJECT MECHANISM ASS'Y)
 PLASTIC : GUIDE: POLYPHTHARAMID UL94V-O BLACK
 : BUTTON: POLYPHTHARAMID UL94V-O BLACK
 PLATE : STAINLESS
 EMI CONTACT: PHOSPHOR BRONZE
 - FINISH (PIN)
 UNDER PLATING : 0.5 μm MIN. Ni
 CONTACT AREA : 0.1 μm MIN. GOLD OVER 0.5 μm MIN. Pd-Ni
 SOLDER TAIL : 2.5 μm MIN. Sn-Pb
 - DIM "X"

4.25±0.1	3.5±0.1	5.0±0.1
OTHERS	36,67	1,17,34,35,51,68

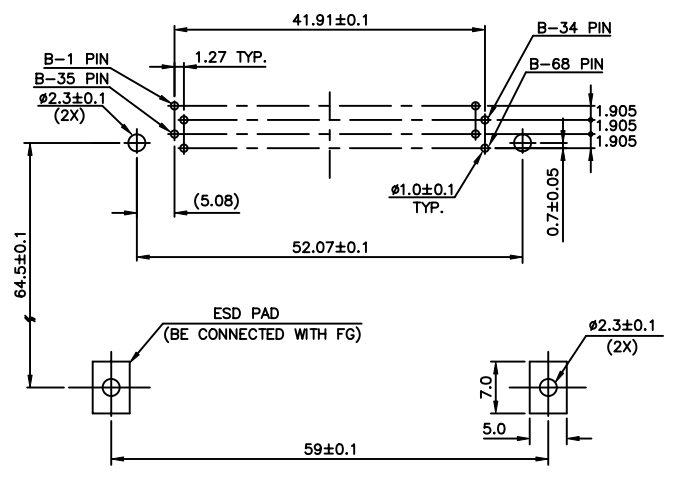

4 CARD INSERTION DIRECTION

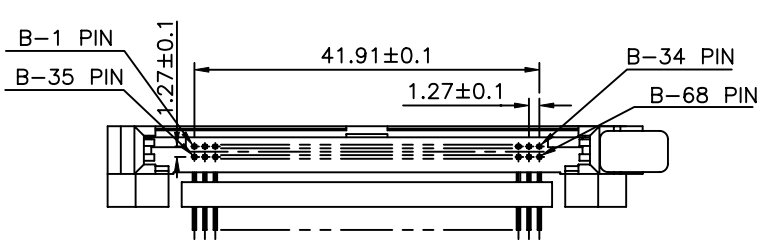

USE THE FOLLOWING P/N FOR OFFICIAL ORDERING

(B)	EJECT MECH ASS'Y	95627-04CA
(A)	HDR ASS'Y	92856-010
DESCRIPTION	P/N	

mat'l code		tolerance unless otherwise specified		CUSTOMER COPY			
rev.	ecn no.	dr	date	linear	±0.30	projection	title
G				angles	± 2°		NARROW BODY FRONT EJECT TYPE 1/2/3 EJECTOR ASS'Y
				dr	WENDY CHEN 11/10/98	unit	product family : PCMCIA
				enr	JOSEPH HSIA 11/10/98	mm/inch	code
				chr	JOSEPH HSIA 11/10/98	scale	TWN
				appd	JENN TSAO 11/10/98	size	7 OF
						A3	61573
sheet	revision						
index	sheet						

PRODUCT NO.
61573-100CA

Tous droits strictement réservés. Reproduction ou communication à des tiers sans autorisation écrite du propriétaire. Droits de reproduction BERG ELECTRONICS by

All rights strictly reserved. Reproduction or issue to third parties in any form without written authority from the proprietor. Property of BERG ELECTRONICS. Copyright BERG ELECTRONICS by

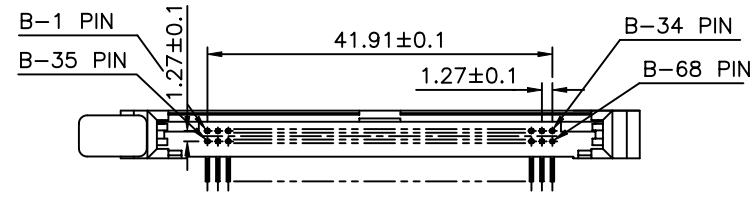
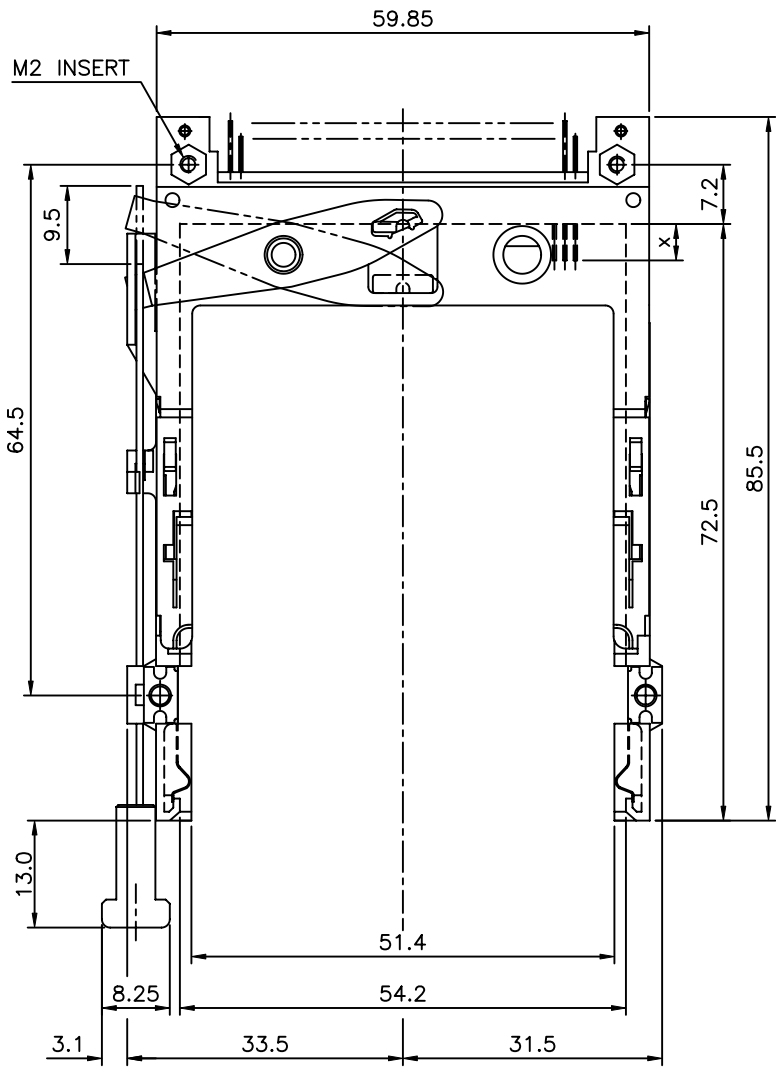
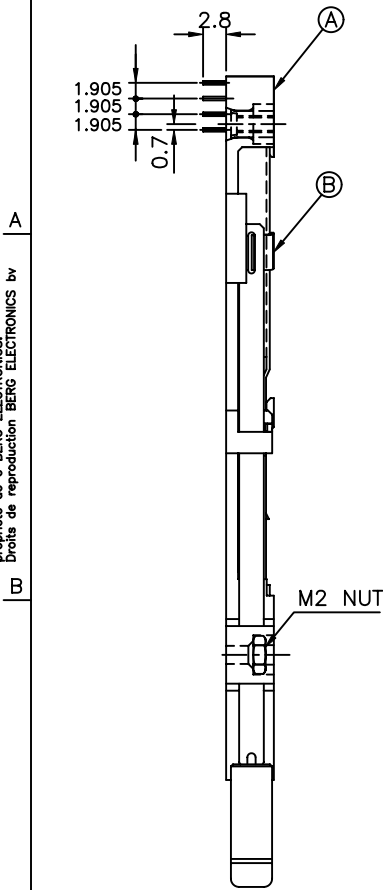

NOTES:

1. EJECT FORCE : 3.5 Kg MAX.
2. EJECT TRAVEL: 8.0mm
3. MATERIAL
 - 3.1 PART (A) (HEADER ASS'Y)
PLASTIC : HOUSING ...LCP UL94V-0 BLACK
PIN : COPPER ALLOY
 - 3.2 PART (B) (EJECT MECHANISM ASS'Y)
PLASTIC : GUIDE: POLYPHTHARAMID UL94V-0 BLACK
 : BUTTON: POLYPHTHARAMID UL94V-0 BLACK
PLATE : STAINLESS
EMI CONTACT: PHOSPHOR BRONZE
4. FINISH (PIN)
UNDER PLATING : 0.5 um MIN. Ni
CONTACT AREA : 0.1 um MIN. GOLD OVER 0.5 um MIN. Pd-Ni
SOLDER TAIL : 2.5 um MIN. Sn-Pb
5. DIM "X"

4.25±0.1	3.5±0.1	5.0±0.1
OTHERS	36,67	1,17,34,35,51,68

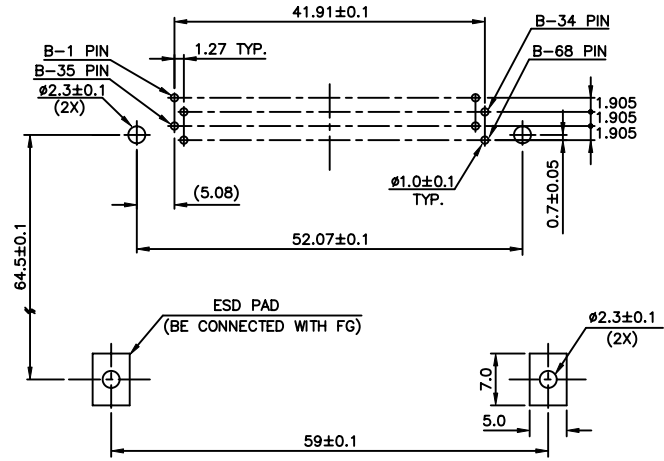

4 CARD INSERTION DIRECTION

USE THE FOLLOWING P/N FOR OFFICIAL ORDERING

(B)	EJECT MECH ASS'Y	95627-10CA
(A)	HDR ASS'Y	92856-000
DESCRIPTION	P/N	

mat'l code		tolerance unless otherwise specified		CUSTOMER COPY		FCI ELECTRONICS	
rev.	ecn no.	dr	date	linear	±0.30	projection	title
G				angles	± 2°		NARROW BODY FRONT EJECT TYPE 1/2/3 EJECTOR ASS'Y
				dr	WENDY CHEN 08/02/99	unit	product family : PCMCIA
				enr	JOSEPH HSIA 08/02/99	mm/inch	code
				chr	JOSEPH HSIA 08/02/99	scale	TWN
				appd	JENN TSAO 08/02/99	1.5:1	sheet
						A3	8 of
						size	dwg no.
							61573
sheet	revision						
index	sheet						

PRODUCT NO.
61573-140CA

Tous droits strictement réservés. Reproduction ou communication à des tiers sans autorisation écrite du propriétaire. Droits de reproduction BERG ELECTRONICS by
 All rights strictly reserved. Reproduction or issue to third parties in any form without written authority from the proprietor. Property of BERG ELECTRONICS. Copyright BERG ELECTRONICS by

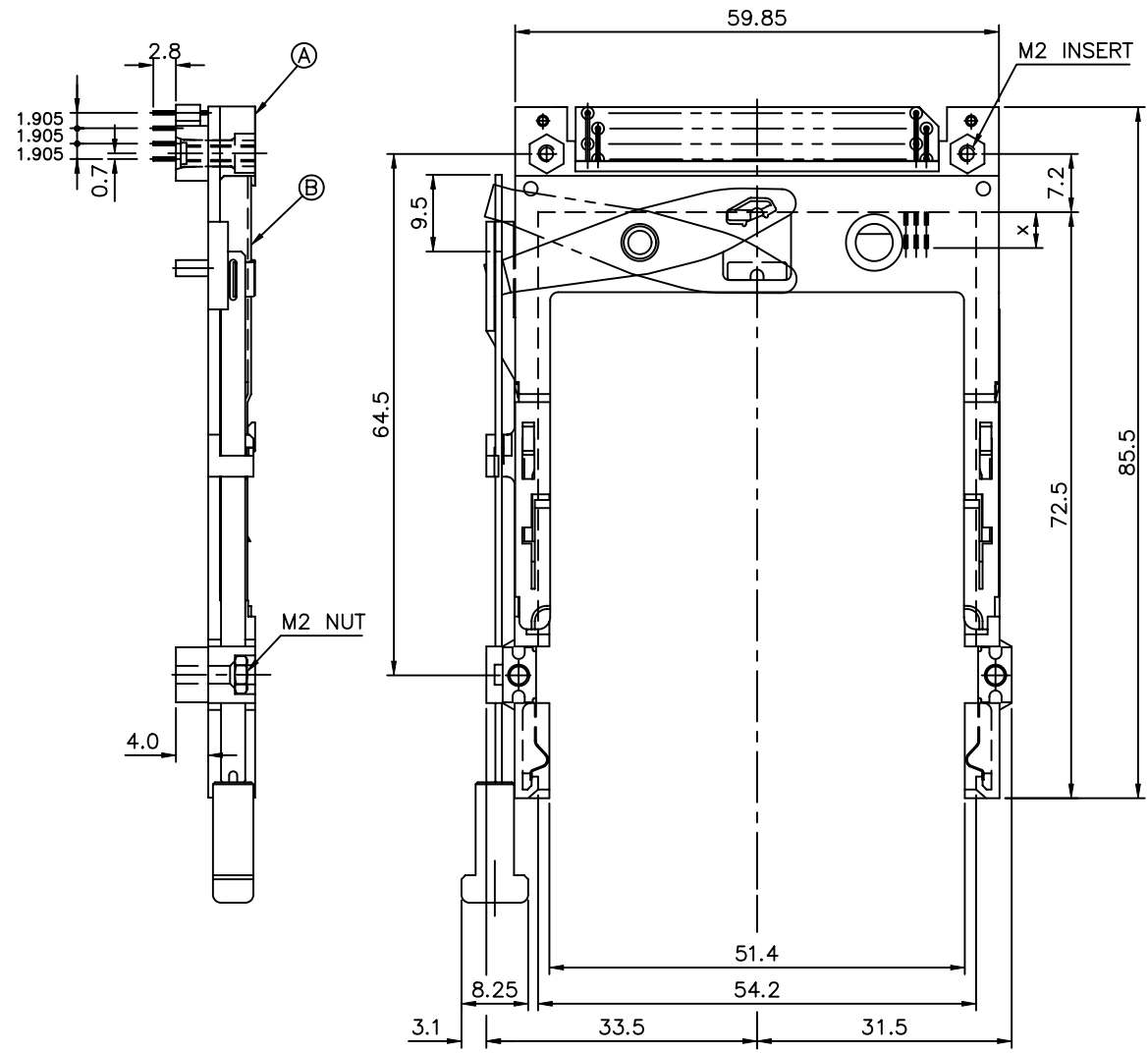

- NOTES:
- EJECT FORCE : 3.5 Kg MAX.
 - EJECT TRAVEL: 8.0mm
 - MATERIAL
 - PART A (HEADER ASS'Y)
 - PLASTIC : HOUSING ...LCP UL94V-0 BLACK
 - LOCATOR ...G.F. 6/6 NYLON UL94-VO BLACK
 - PIN : COPPER ALLOY
 - PART B (EJECT MECHANISM ASS'Y)
 - PLASTIC : GUIDE: POLYPHTHARAMID UL94V-0 BLACK
 - BUTTON: POLYPHTHARAMID UL94V-0 BLACK
 - PLATE : STAINLESS
 - EMI CONTACT: PHOSPHOR BRONZE
 - FINISH (PIN)
 - UNDER PLATING : 0.5 μm MIN. Ni
 - CONTACT AREA : 0.1 μm MIN. GOLD OVER 0.5 μm MIN. Pd-Ni
 - SOLDER TAIL : 2.5 μm MIN. Sn-Pb
 - DIM "X"

4.25±0.1	3.5±0.1	5.0±0.1
OTHERS	36,67	1,17,34,35,51,68

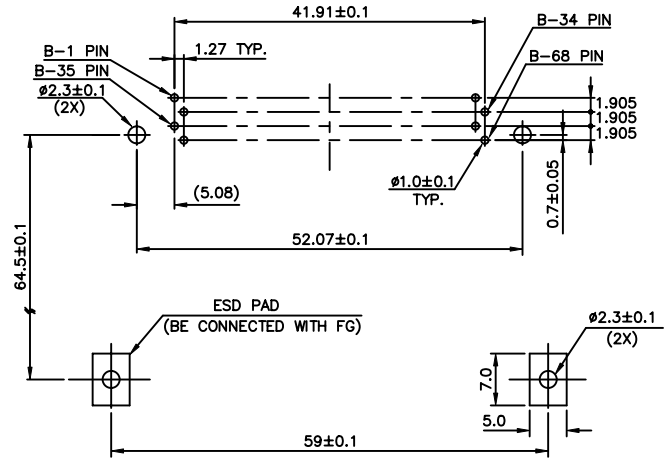

4 CARD INSERTION DIRECTION

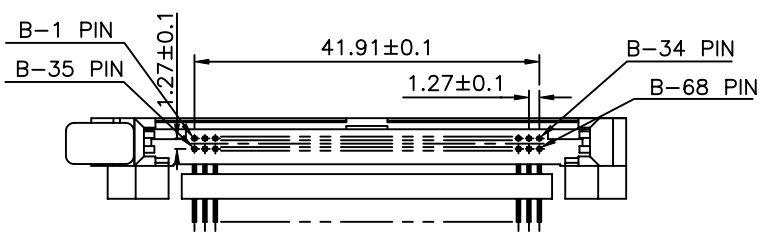

USE THE FOLLOWING P/N FOR OFFICIAL ORDERING

B	EJECT MECH ASS'Y	95627-14CA
A	HDR ASS'Y	92856-010
DESCRIPTION	P/N	

mat'l code		tolerance unless otherwise specified		CUSTOMER COPY			
rev.	ecn no.	dr	date	linear	±0.30	projection	title
H				angles	± 2°		NARROW BODY FRONT EJECT TYPE 1/2/3 EJECTOR ASS'Y
				dr	WENDY CHEN 05/04/00	unit	product family : PCMCIA
				enr	JOSEPH HSIA 05/04/00	mm/inch	code
				chr	JOSEPH HSIA 05/04/00	scale	TWN
				appd	JOSEPH HSIA 05/04/00	1.5:1	sheet
						A3	9 OF
sheet	revision						
index	sheet						