



Chipsmall Limited consists of a professional team with an average of over 10 year of expertise in the distribution of electronic components. Based in Hongkong, we have already established firm and mutual-benefit business relationships with customers from,Europe,America and south Asia,supplying obsolete and hard-to-find components to meet their specific needs.

With the principle of “Quality Parts,Customers Priority,Honest Operation,and Considerate Service”,our business mainly focus on the distribution of electronic components. Line cards we deal with include Microchip,ALPS,ROHM,Xilinx,Pulse,ON,Everlight and Freescale. Main products comprise IC,Modules,Potentiometer,IC Socket,Relay,Connector.Our parts cover such applications as commercial,industrial, and automotives areas.

We are looking forward to setting up business relationship with you and hope to provide you with the best service and solution. Let us make a better world for our industry!



Contact us

Tel: +86-755-8981 8866 Fax: +86-755-8427 6832

Email & Skype: info@chipsmall.com Web: www.chipsmall.com

Address: A1208, Overseas Decoration Building, #122 Zhenhua RD., Futian, Shenzhen, China





ASTRO TOOL CORP.

CONNECTOR ASSEMBLY TOOLING

616336 8-STEP ADJUSTABLE CRIMP TOOL M22520/7-01(NSN: 5120-00-133-1747)

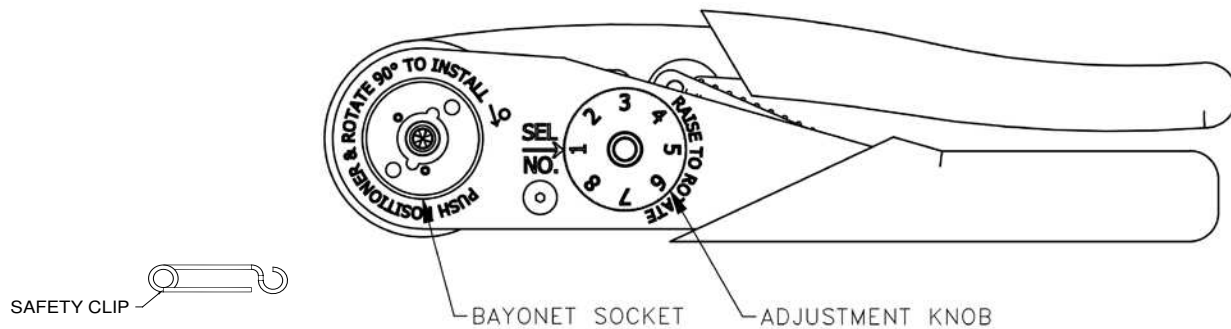

GENERAL

The Astro Tool 616336 8-step crimp tool is a cycle controlled, precision crimp tool capable of crimping wire barrel sizes 16 to 22.

Observe the precision ratchet action by opening and closing the tool several times. Note that the tool cannot be opened without fully completing the crimp cycle. When held, the tool fits your hand for less fatiguing one hand operation.

BASIC TOOL OPERATION

NOTE: For proper crimping, the Basic Tool must be used with an appropriate Positioner Assembly.

1. Tool must be in full open position.
2. Remove the Safety Clip from the Bayonet Socket.
3. Select the proper Positioner Assembly for the contact to be crimped.

4. Place the Positioner Assembly in the Bayonet Socket. Line up the pins on the Positioner Assembly with the slots on the Bayonet Socket. Depress the Positioner Assembly and rotate 90° clockwise and release. The Positioner Assembly should be locked in place.

5. Insert the Safety Clip back into the Bayonet Socket (optional).

6. Consult the Data Plate on the face of the Positioner Assembly for the proper selector setting. With tool handles in the open position, grasp the Adjustment Knob; raise and rotate until the proper selector setting is lined up with the arrow on the Top Handle. Release the Adjustment Knob.

7. Insert the contact through the Indenter Opening and into the Positioner Assembly.

8. Insert the wire into the contact. Squeeze the handles until the Tool comes to a positive stop. Release the handles and the tool will return to the full open position.

9. Remove the completed crimped assembly.

CAUTION:

Do not press down on the wire during the crimp cycle.

GAGING INSTRUCTIONS

Gaging the tool requires the M22520/3-03 Gage Pin Assembly, Astro part # 616337.

1. Set the tool to selector setting # 8.
2. Close the handles to the fully closed position.
3. Holding the tool closed, insert the GO pin into the indenter opening as shown, see figure # 1 The gage must pass freely between the indenter tips.
4. Holding the tool closed, insert the NO GO pin into the indenter opening. The gage pin must NOT go between the indenter tips.

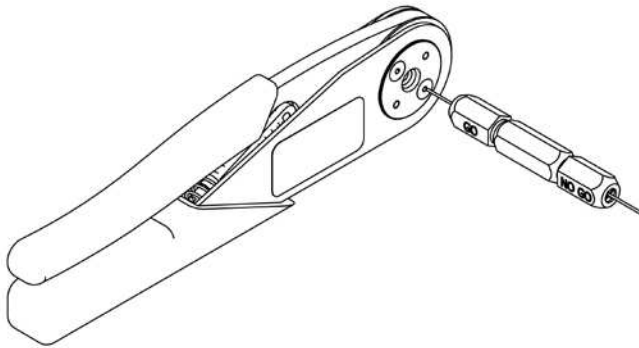

Figure # 1

CAUTION:
DO NOT CRIMP GAGE. TOOL DAMAGE
WILL RESULT.

Astro manufactures the ATK6004 gaging kit with gage pin assemblies for each selector setting. Contact the factory for price and availability.

GAGING INFORMATION

| SELECTOR SETTING NUMBER | GO SIZE $\pm .0001$ | NO GO SIZE $\pm .0001$ |
|-------------------------|------------------------|---------------------------|
| 1 | .0160 | .0210 |
| 2 | .0190 | .0240 |
| 3 | .0220 | .0270 |
| 4 | .0250 | .0300 |
| 5 | .0290 | .0340 |
| 6 | .0330 | .0380 |
| 7 | .0370 | .0420 |
| 8 | .0410 | .0460 |

TOOL SERVICE

Astro Tool's 616336 Crimp Tool is designed for long, reliable service. If the tool becomes inoperative or does not gage properly, it is suggested that you contact our Customer Service Department for a Return Goods Authorization number and return the tool to our factory. Please note that Astro's Quality Control system is traceable to The National Institute of Standards and Technology (N.I.S.T.).

Upon receipt of the tool, Astro will inspect and overhaul each tool to put the tool back into acceptable and efficient operating condition. Worn parts will be replaced or repaired.

Service charges for tools not under warranty will be advised upon request.

Parts that Astro deems to have been damaged due to neglect, misuse or accident; and parts that have been altered or repaired by persons other than Astro Tool Corp. employees will be replaced subject to additional charge for such parts.

TOOL IS PERMANENTLY LUBRICATED AT THE FACTORY, DO NOT OIL

ASTRO TOOL CORP. MANUFACTURERS OF INSERTION, REMOVAL, CRIMP TOOLS AND CONNECTOR SERVICE KITS

ASTRO TOOL CORPORATION • 21615 S.W. T-V HWY. • BEAVERTON OREGON 97003
503-642-9853 • FAX 503-591-7766