



Chipsmall Limited consists of a professional team with an average of over 10 year of expertise in the distribution of electronic components. Based in Hongkong, we have already established firm and mutual-benefit business relationships with customers from,Europe,America and south Asia,supplying obsolete and hard-to-find components to meet their specific needs.

With the principle of "Quality Parts,Customers Priority,Honest Operation,and Considerate Service",our business mainly focus on the distribution of electronic components. Line cards we deal with include Microchip,ALPS,ROHM,Xilinx,Pulse,ON,Everlight and Freescale. Main products comprise IC,Modules,Potentiometer,IC Socket,Relay,Connector.Our parts cover such applications as commercial,industrial, and automotives areas.

We are looking forward to setting up business relationship with you and hope to provide you with the best service and solution. Let us make a better world for our industry!



Contact us

Tel: +86-755-8981 8866 Fax: +86-755-8427 6832

Email & Skype: info@chipsmall.com Web: www.chipsmall.com

Address: A1208, Overseas Decoration Building, #122 Zhenhua RD., Futian, Shenzhen, China



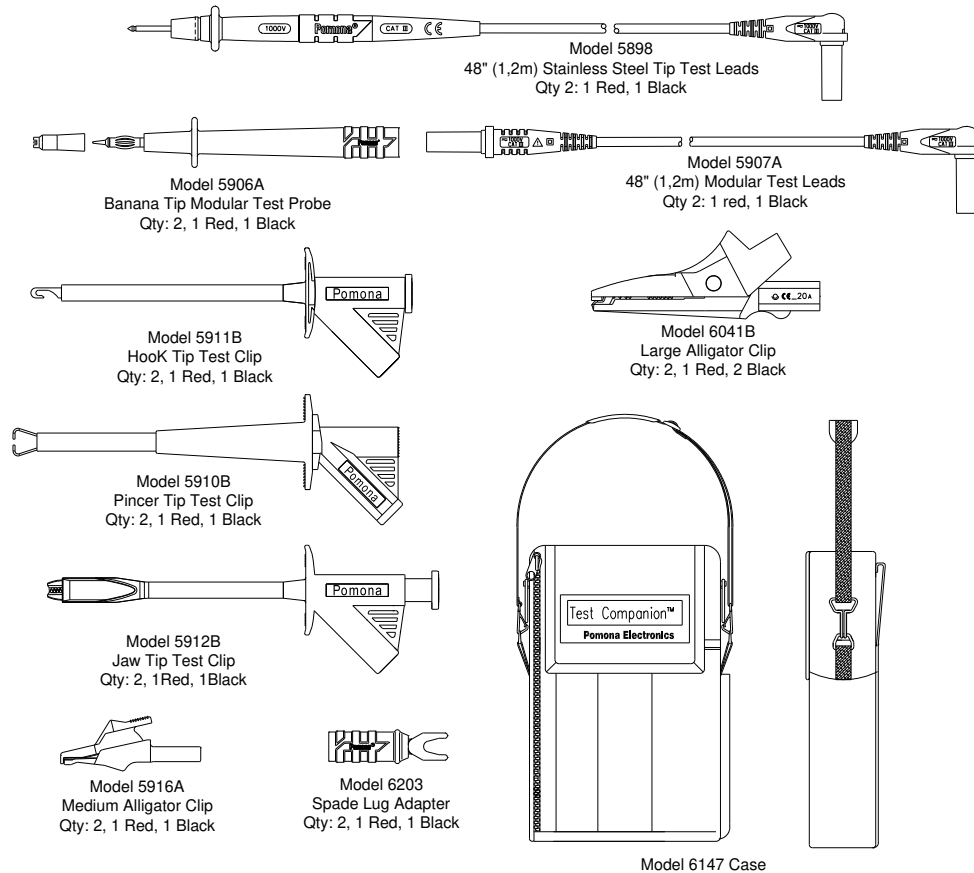

For data sheets / specifications of the kit individual components, visit the Pomona web site at:
www.pomonaelectronics.com

FEATURES:

- ✓ Test leads with a right angle banana plug are ideal for use with hand held digital multimeter.
- ✓ Flexible test leads feature high strand count silicone wire for extreme flexibility and high temperature resistance.
- ✓ Banana plugs are molded directly to the wire for superior pull strength.
- ✓ Banana tip probe body, alligators, spade lug and test clips attaches directly to test leads for testing versatility
- ✓ Test accessories conveniently store in the shoulder-pack with carrying strap.
- ✓ Compatible with most multimeters that accepts safety style sheath banana plugs.
- ✓ CE Compliant; complies with IEC 1010-2-031 standard for hand held accessories.

All dimensions are in inches. Tolerances (except noted): .xx = ±.02" (.51 mm), .xxx = ±.005" (.127 mm).

All specifications are to the latest revisions. Specifications are subject to change without notice.

Registered trademarks are the property of their respective companies.

Sales: 800-490-2361 Fax: 888-403-3360 Technical Assistance: 800-241-2060
For "Where to Buy" information, visit the Pomona web site at www.pomonaelectronics.com

Pomona[®]

The items included with this product are certified to meet IEC 1010-2-031 safety requirements.

Les éléments inclus avec ce produit sont certifiés pour répondre à des exigences de sûreté du IEC 1010-2-031.

Los items incluidos con este producto se certifican para resolver requisitos de seguridad del IEC 1010-2-031.

- Only IEC 1010 type shrouded test plugs should be used with IEC 1010 type jacks. NEVER INSERT A PROBE TIP WITH BANANA SPRING INTO A TEST ACCESSORY JACK THAT WILL BE USED AS A HAND HELD PROBING DEVICE

-Seuls les vérificateurs de tension renforcés de type IEC 1010 devraient être utilisés avec des jacks de type IEC 1010. NE JAMAIS INSERER DE BOUT DE SONDE AVEC RESSORT BANANE DANS UN JACK D'ESSAI D'ACCESSOIRES QUI SERA UTILISE COMME DISPOSITIF DE SONDAGE A MAIN.

-Se deben usar sólo tapones de prueba reforzados del tipo IEC 1010 con receptáculos de tipo IEC 1010. NUNCA INTRODUZCA UNA CLAVIJA CON UN MUELLE TIPO BANANA EN UN RECEPTACULO DE PRUEBA QUE A SU VEZ SE USE COMO APARATO DE PRUEBA MANUAL.



Both Direct and Alternating Current.
Courant Continu et Alternatif.
Corriente Directa y Alterna.



Caution ! Refer to Accompanying Documents.
Attention ! Se Reporter aux Documents joints.
¡ Peligro! Consulte los Documentos Adjuntos.



Double Insulation or Reinforced Insulation.
Isolation Double ou Isolation Renforcée.
Aislamiento Doble o Aislamiento Reforzado.



Caution ! Risk of Electric Shock.
Attention ! Risque de Choc Électrique.
¡ Peligro! Riesgo de Sacudida Eléctrica.

CAT

Overtension Category I, II, III or IV.
Surtension Catégorie I, II, III ou IV.
Sobretensión de Categoría I, II III o IV.

Pomona Electronics



PO Box 9090, Everett, WA 98206-9090 TEL: 800-490-2361

All dimensions are in inches. Tolerances (except noted): .xx = ±.02" (.51 mm), .xxx = ± .005" (.127 mm).

All specifications are to the latest revisions. Specifications are subject to change without notice.

Registered trademarks are the property of their respective companies.

Sales: 800-490-2361 Fax: 888-403-3360 Technical Assistance: 800-241-2060
For "Where to Buy" information, visit the Pomona web site at www.pomonaelectronics.com