



Chipsmall Limited consists of a professional team with an average of over 10 year of expertise in the distribution of electronic components. Based in Hongkong, we have already established firm and mutual-benefit business relationships with customers from,Europe,America and south Asia,supplying obsolete and hard-to-find components to meet their specific needs.

With the principle of “Quality Parts,Customers Priority,Honest Operation,and Considerate Service”,our business mainly focus on the distribution of electronic components. Line cards we deal with include Microchip,ALPS,ROHM,Xilinx,Pulse,ON,Everlight and Freescale. Main products comprise IC,Modules,Potentiometer,IC Socket,Relay,Connector.Our parts cover such applications as commercial,industrial, and automotives areas.

We are looking forward to setting up business relationship with you and hope to provide you with the best service and solution. Let us make a better world for our industry!



Contact us

Tel: +86-755-8981 8866 Fax: +86-755-8427 6832

Email & Skype: info@chipsmall.com Web: www.chipsmall.com

Address: A1208, Overseas Decoration Building, #122 Zhenhua RD., Futian, Shenzhen, China



**Model 6173A
Deluxe Industrial Test Companion Kit**

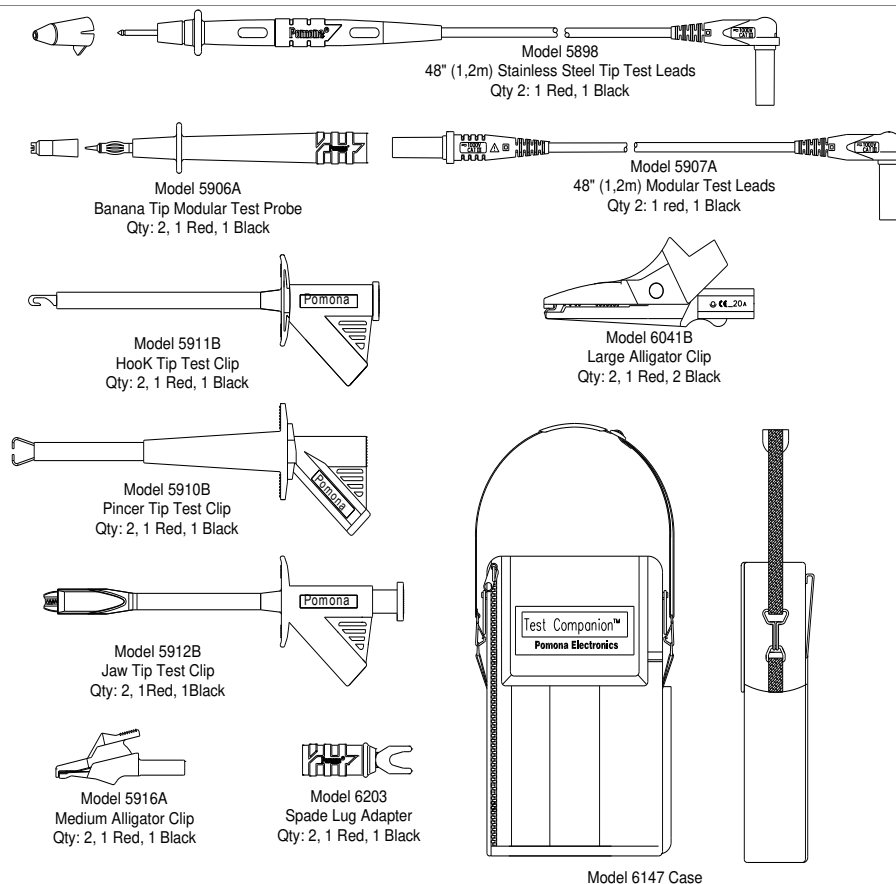

For data sheets / specifications of the kit individual components, visit the Pomona web site at:
www.pomonaelectronics.com

FEATURES:

- Test leads with a right angle banana plug are ideal for use with hand held digital multimeter.
- Flexible test leads feature high strand count silicone wire for extreme flexibility and high temperature resistance.
- Wear indication with double insulated (dual extruded) silicone leads shows white inner layer for increased safety.
- Banana plugs are molded directly to the wire for superior pull strength.
- Banana tip probe body, alligators, spade lug and test clips attaches directly to test leads for testing versatility
- Test accessories conveniently store in the shoulder-pack with carrying strap.
- Compatible with most multimeters that accepts safety style sheath banana plugs.
- CE Compliant; complies with IEC 61010-031 standard for hand held accessories.



USA: Sales: 800-490-2361
Technical Support: technicalsupport@pomonatest.com
Fax: 425-446-5844

Europe: 31-(0) 40 2675 150 **International:** 425-446-5500
Where to Buy: www.pomonaelectronics.com

All dimensions are in inches. Tolerances (except noted): .xx = ±.02" (.51 mm),
.xxx = ±.005" (.127 mm). All specifications are to the latest revisions.
Specifications are subject to change without notice. Registered trademarks are
the property of their respective companies.