



Chipsmall Limited consists of a professional team with an average of over 10 year of expertise in the distribution of electronic components. Based in Hongkong, we have already established firm and mutual-benefit business relationships with customers from,Europe,America and south Asia,supplying obsolete and hard-to-find components to meet their specific needs.

With the principle of “Quality Parts,Customers Priority,Honest Operation,and Considerate Service”,our business mainly focus on the distribution of electronic components. Line cards we deal with include Microchip,ALPS,ROHM,Xilinx,Pulse,ON,Everlight and Freescale. Main products comprise IC,Modules,Potentiometer,IC Socket,Relay,Connector.Our parts cover such applications as commercial,industrial, and automotives areas.

We are looking forward to setting up business relationship with you and hope to provide you with the best service and solution. Let us make a better world for our industry!



Contact us

Tel: +86-755-8981 8866 Fax: +86-755-8427 6832

Email & Skype: info@chipsmall.com Web: www.chipsmall.com

Address: A1208, Overseas Decoration Building, #122 Zhenhua RD., Futian, Shenzhen, China



611/621

611/621-Series

SMALL-SIZED ROCKER SWITCHES

The 611/621-Series small-size, sleek styling, actuator and termination choices make this switch a cost effective solution to most any switching need. International approvals, single or double pole circuitry, and ratings to 11A 125VAC further the broad appeal of this product family.



Product Highlights:

- ◆ Single or double pole
- ◆ Paddle and single color or dual color visi-rocker options
- ◆ UL, CSA and VDE approvals for select circuits
- ◆ Choice of 7 termination options

Typical Applications:

- ◆ Appliance
- ◆ Audio-Visual
- ◆ Power Supplies



Dielectric Strength

UL/CSA:
 1000V - live to dead metal parts & opposite polarity
 VDE: 4000V - live to dead metal parts;
 1250V - opposite polarity & across open contacts

Electrical Life

50,000 cycles- single pole
 50,000 cycles- double pole

Operating Temperature

32°F to 185°F (0°C to 85°C)

Mechanical Life

100,000 cycles

62116919 - 0 - 9 - V

¹
 Base Part Number

²
 Epoxy Sealing

³
 Rocker Legend

⁴
 Visi-Rocker End Color

1 BASE PART NUMBER: SERIES / CIRCUITRY / RATING ² / TERMINATION

	187 Tabs ⁴	.080 Solder Lugs	PC Terms	Wire Leads	PC Front Mount	PC Back Mount	.187 Solder Lugs
Single Pole; 4A 250VAC; 8A 125VAC; 6(4) A 250V ⁴							
ON-NONE-OFF	62116919	-	-	62111914	62111918 ⁶	62111917 ⁶	62111916
ON-NONE-ON	62116929	62116421	62111422	62111924	62111928 ⁶	62111927 ⁶	62111926
ON-OFF-ON ³	-	62111461	62111462	62111263 ⁷	-	-	-
ON-NONE-(ON) ³	-	62111431	62111432	62111233 ⁷	-	-	-
ON-OFF-(ON) ³	-	62111471	62111472	62111273 ⁷	-	-	-
(ON)-OFF-(ON) ³	-	62111481	62111482	62111283 ⁷	-	-	-
Double Pole: 4A 250VAC; 8A 125VAC; 6(4) A 250V ⁴							
ON-NONE-OFF	62115919	-	-	62112914	62112918 ⁶	62112917 ⁶	62112916
ON-NONE-ON	62115929	62112421	62112422	62112924	62112928 ⁶	62112927 ⁶	62112926
ON-OFF-ON ³	-	62112461	62112462	62112263 ⁷	-	-	-
ON-NONE-(ON) ³	-	62112431	62112432	62112233 ⁷	-	-	-
ON-OFF-(ON) ³	-	62112471	62112472	62112273 ⁷	-	-	-
(ON)-OFF-(ON) ³	-	62112481	62112482	62112283 ⁷	-	-	-

2 TERMINAL SEALING

0	None	E	Epoxy sealed terminals
---	------	---	------------------------

3 ROCKER LEGEND

NO LEGEND	molded in ⁵	hot stamp
0	0	0
Off-On vertical	n/a	A
Off-On horizontal	n/a	B
I-O horizontal	8	D
I-O vertical	9	E
O on rocker radius	n/a	F (Indicates ON)

4 VISI-ROCKER END COLOR

N	n/a
V	visi-red
W	visi-white

Notes:

- Base part number specifies black rocker with black bezel. To specify paddle actuator change 2nd digit from 2 to 1. ex.: 61115919 = black paddle with black bezel. For additional ratings & colors, consult factory.
- Dry circuit rating is available, consult factory.
- Not available with 6(4) A 250 V rating or VDE approval.
- 6(4)A 250V VDE approved rating available with On-none-Off and On-none-On circuits only.
- Available with visi-rocker option only.
- Consult factory for PC footprint.
- Rated 2A 250VAC, 5A 125 VAC resistive.
- () Indicates momentary function.

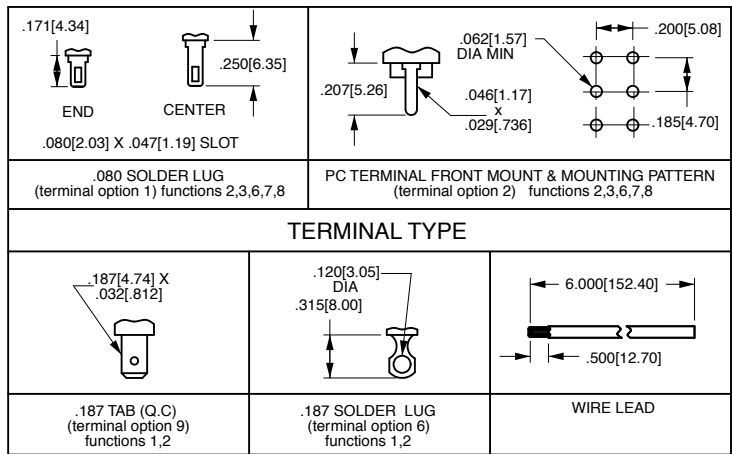
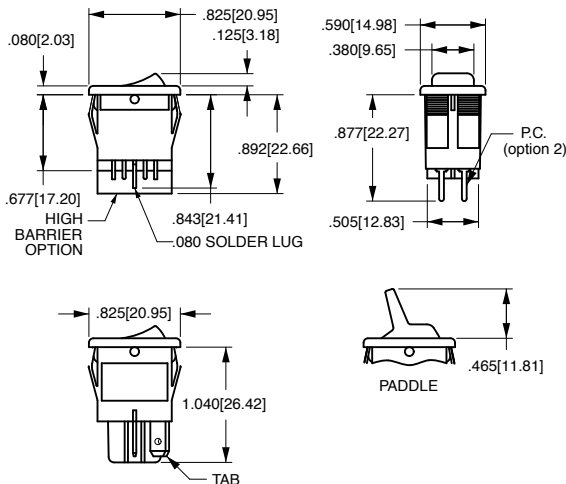

PANEL THICKNESS	X	Y
.030[.762]-.060[1.52]	.508[12.90]	.756[19.20]
.060[1.52]-.093[2.36]	.508[12.90]	.764[19.40]
.093[2.36]-.156[3.96]	.508[12.90]	.780[19.81]

TEST CUT HOLE IN ACTUAL MATERIAL

*Manufacturer reserves the right to change product specification without prior notice.

Authorized Sales Representatives and Distributors

Click on a region of the map below to find your local representatives and distributors or visit www.carlingtech.com/findarep.



About Carling

Founded in 1920, Carling Technologies is a leading manufacturer of electrical and electronic switches and assemblies, circuit breakers, electronic controls, power distribution units, and multiplexed power distribution systems. With four ISO registered manufacturing facilities and technical sales offices worldwide, Carling Technologies Sales, Service and Engineering teams do much more than manufacture electrical components, they engineer powerful solutions! To learn more about Carling please visit www.carlingtech.com/company-profile.

To view all of Carling's environmental, quality, health & safety certifications please visit www.carlingtech.com/environmental-certifications

Worldwide Headquarters

Carling Technologies, Inc.
60 Johnson Avenue, Plainville, CT 06062
Phone: 860.793.9281 **Fax:** 860.793.9231
Email: sales@carlingtech.com

Northern Region Sales Office: nrsm@carlingtech.com
Southeast Region Sales Office: sersm@carlingtech.com
Midwest Region Sales Office: mrrsm@carlingtech.com
West Region Sales Office: wrsm@carlingtech.com
Latin America Sales Office: larsm@carlingtech.com

Asia-Pacific Headquarters

Carling Technologies, Asia-Pacific Ltd.,
Suite 1607, 16/F Tower 2, The Gateway,
Harbour City, 25 Canton Road,
Tsimshatsui, Kowloon, Hong Kong
Phone: Int + 852-2737-2277 **Fax:** Int + 852-2736-9332
Email: sales@carlingtech.com.hk

Shenzhen, China: shenzhen@carlingtech.com
Shanghai, China: shanghai@carlingtech.com
Pune, India: india@carlingtech.com
Kaohsiung, Taiwan: taiwan@carlingtech.com
Yokohama, Japan: japan@carlingtech.com

Europe | Middle East | Africa Headquarters

Carling Technologies LTD
4 Airport Business Park, Exeter Airport,
Clyst Honiton, Exeter, Devon, EX5 2UL, UK
Phone: Int + 44 1392.364422 **Fax:** Int + 44 1392.364477
Email: ltd.sales@carlingtech.com

Germany: gmbh@carlingtech.com
France: sas@carlingtech.com



Carling Technologies®

Innovative Designs. Powerful Solutions.