



Chipsmall Limited consists of a professional team with an average of over 10 year of expertise in the distribution of electronic components. Based in Hongkong, we have already established firm and mutual-benefit business relationships with customers from,Europe,America and south Asia,supplying obsolete and hard-to-find components to meet their specific needs.

With the principle of “Quality Parts,Customers Priority,Honest Operation,and Considerate Service”,our business mainly focus on the distribution of electronic components. Line cards we deal with include Microchip,ALPS,ROHM,Xilinx,Pulse,ON,Everlight and Freescale. Main products comprise IC,Modules,Potentiometer,IC Socket,Relay,Connector.Our parts cover such applications as commercial,industrial, and automotives areas.

We are looking forward to setting up business relationship with you and hope to provide you with the best service and solution. Let us make a better world for our industry!



Contact us

Tel: +86-755-8981 8866 Fax: +86-755-8427 6832

Email & Skype: info@chipsmall.com Web: www.chipsmall.com

Address: A1208, Overseas Decoration Building, #122 Zhenhua RD., Futian, Shenzhen, China



4

3

2

1

THIS DRAWING IS UNPUBLISHED. RELEASED FOR PUBLICATION
 © COPYRIGHT BY TYCO ELECTRONICS CORPORATION. ALL RIGHTS RESERVED.

LOC	DIST	REVISIONS			
P	LTR	DESCRIPTION	DATE	DWN	APVD
AF	50	K	REV PER 0G3A-0787-03	15DEC03	JR GP

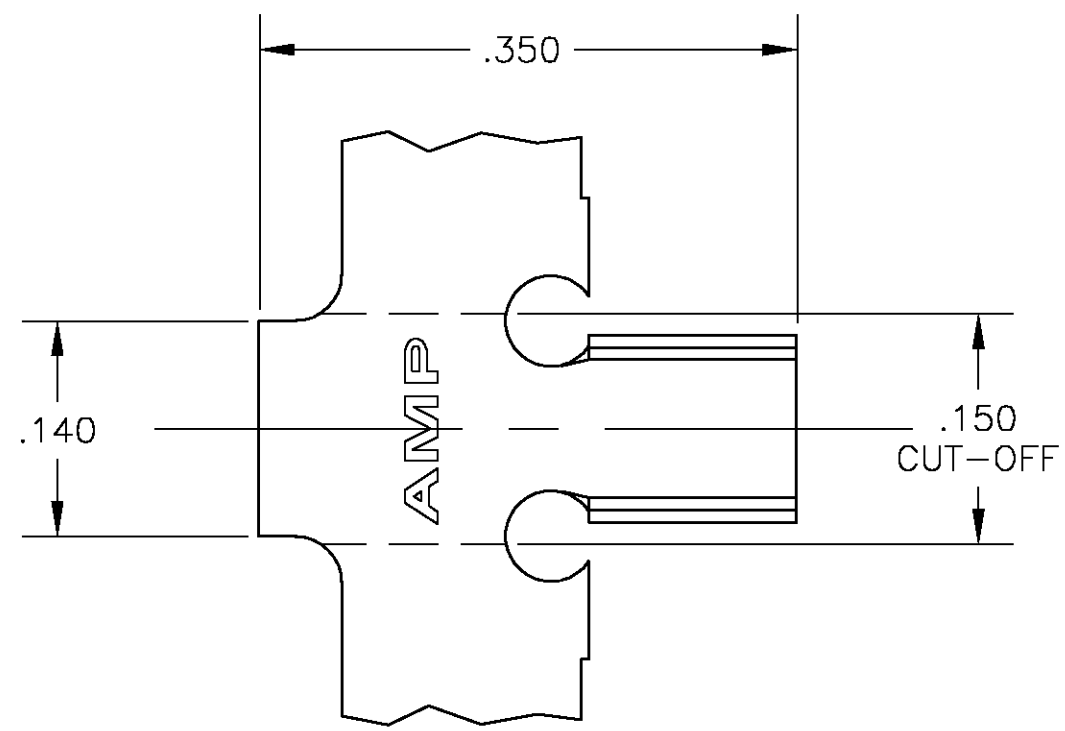

- 1 CONTINUOUS STRIP ON REELS
- 2 WIRE SIZE IS #18-#14 OR TWO #18'S

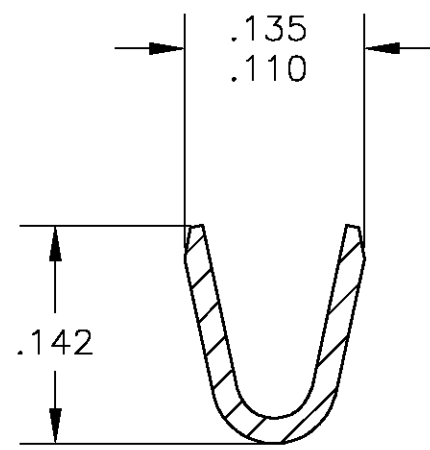
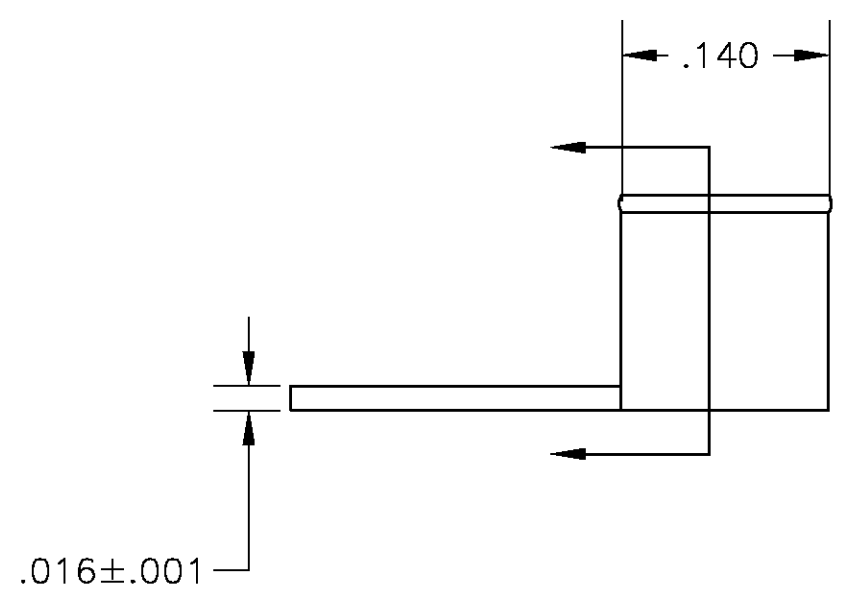

62134-2
 PART NO

THIS DRAWING IS A CONTROLLED DOCUMENT.		DWN jr_ruth 15DEC2003	Tyco Electronics Corporation City, State, Zip			
DIMENSIONS: INCHES		CHK G PORTA 15DEC03				
TOLERANCES UNLESS OTHERWISE SPECIFIED:		APVD G PORTA 15DEC03	NAME CONTACT			
0 PLC ± - 1 PLC ± - 2 PLC ± - 3 PLC ± .010 4 PLC ± - ANGLES ± -		PRODUCT SPEC -	APPLICATION SPEC -			
MATERIAL TEMP 2 STEEL		FINISH NICKEL	SIZE A3	CAGE CODE 00779	DRAWING NO C-62134	RESTRICTED TO -
CUSTOMER DRAWING			SCALE 8:1	SHEET 1 OF 1	REV K	