



Chipsmall Limited consists of a professional team with an average of over 10 year of expertise in the distribution of electronic components. Based in Hongkong, we have already established firm and mutual-benefit business relationships with customers from,Europe,America and south Asia,supplying obsolete and hard-to-find components to meet their specific needs.

With the principle of "Quality Parts,Customers Priority,Honest Operation,and Considerate Service",our business mainly focus on the distribution of electronic components. Line cards we deal with include Microchip,ALPS,ROHM,Xilinx,Pulse,ON,Everlight and Freescale. Main products comprise IC,Modules,Potentiometer,IC Socket,Relay,Connector.Our parts cover such applications as commercial,industrial, and automotives areas.

We are looking forward to setting up business relationship with you and hope to provide you with the best service and solution. Let us make a better world for our industry!



Contact us

Tel: +86-755-8981 8866 Fax: +86-755-8427 6832

Email & Skype: info@chipsmall.com Web: www.chipsmall.com

Address: A1208, Overseas Decoration Building, #122 Zhenhua RD., Futian, Shenzhen, China



Model 6248 Minigrabber® Test Clip to Sheathed Banana Jack

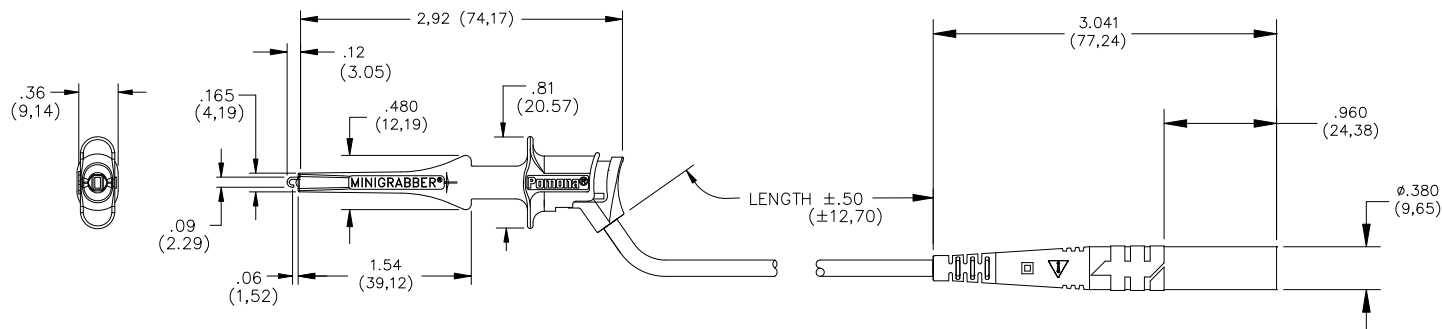

Features

- Newly designed Minigrabber® Test Clip Patch Cord complies with IEC 61010-2-31, which is the latest international safety standard for test accessories.
- Grabber width is a slim .36" (9,14 mm) for easier access to test terminals.
- Grabber hook is gold plated beryllium copper to ensure signal integrity & attaches onto component leads up to .060" (1,5 mm) O.D.
- Grabber patch cord can connect directly to Pomona's sheathed type flexible tests leads for added patch cord length.
- Banana jack is molded directly to the cable for a long lasting connection.
- High strand count silicone insulated wire offers excellent flexibility and high temperature resistance.

Materials

Grabber: Body: Polypropylene, Color per Part Number
Hook: Beryllium Copper, Gold Plated, compression Spring: Music Wire
Wire: 18 AWG, 65 x 36 Tinned Copper, Insulation – Silicone, .144" (3,66 mm) O.D., Color per P/N
Banana Jack: Body – Brass, Nickel Plated
Insulation – Polypropylene, Color per P/N

Ratings

IEC 61010 2-031, Category II, P2 Compliant
Operating Voltage: 300 VRMS/DC Max.
Current: 5 Amperes Max.

Ordering Information

Model 6248-XX-*
XX = Lead Length in Inches, Standard Length: 12" (30,48 cm)
* = Color Code, -0 Black and -2 Red
Additional lengths can be quoted upon request.

USA: Sales: 800-490-2361
Technical Support: technicalsupport@pomonatest.com
Fax: 425-446-5844
Europe: 31-(0) 40 2675 150 **International:** 425-446-5500
Where to Buy: www.pomonaelectronics.com

All dimensions are in inches. Tolerances (except noted): .xx = ±.02" (.51 mm), .xxx = ±.005" (.127 mm). All specifications are to the latest revisions. Specifications are subject to change without notice. Registered trademarks are the property of their respective companies.