



Chipsmall Limited consists of a professional team with an average of over 10 year of expertise in the distribution of electronic components. Based in Hongkong, we have already established firm and mutual-benefit business relationships with customers from,Europe,America and south Asia,supplying obsolete and hard-to-find components to meet their specific needs.

With the principle of “Quality Parts,Customers Priority,Honest Operation,and Considerate Service”,our business mainly focus on the distribution of electronic components. Line cards we deal with include Microchip,ALPS,ROHM,Xilinx,Pulse,ON,Everlight and Freescale. Main products comprise IC,Modules,Potentiometer,IC Socket,Relay,Connector.Our parts cover such applications as commercial,industrial, and automotives areas.

We are looking forward to setting up business relationship with you and hope to provide you with the best service and solution. Let us make a better world for our industry!



Contact us

Tel: +86-755-8981 8866 Fax: +86-755-8427 6832

Email & Skype: info@chipsmall.com Web: www.chipsmall.com

Address: A1208, Overseas Decoration Building, #122 Zhenhua RD., Futian, Shenzhen, China





FEATURES

- Standard 2.5mm x 2.0mm 4-Pad Surface Mount Package
- HCMOS Output
- Fundamental and 3rd Overtone Crystal Designs
- Frequency Range 1 – 110 MHz
- Frequency Stability ± 50 ppm Standard, ± 25 ppm and ± 20 ppm Available
- Operating Voltages +1.8Vdc, +2.5Vdc or +3.3Vdc
- Operating Temperature to -40°C to +85°C
- Output Enable Standard
- Tape & Reel Packaging Standard, EIA-418
- **RoHS/ Green Compliant [6/ 6]**

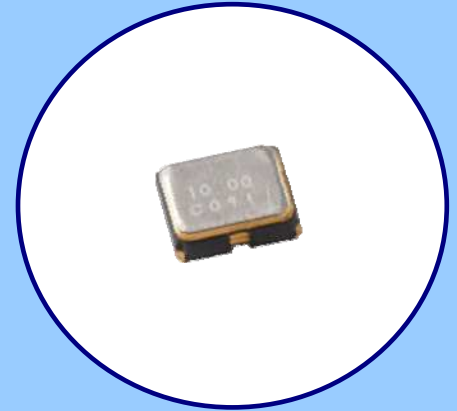

APPLICATIONS

Model 625 is ideal for applications; such as broadband access, Ethernet/Gigabit Ethernet, microprocessors/DSP/FPGA, networking equipment computers and peripherals, digital video, cameras and other portable devices.

ORDERING INFORMATION

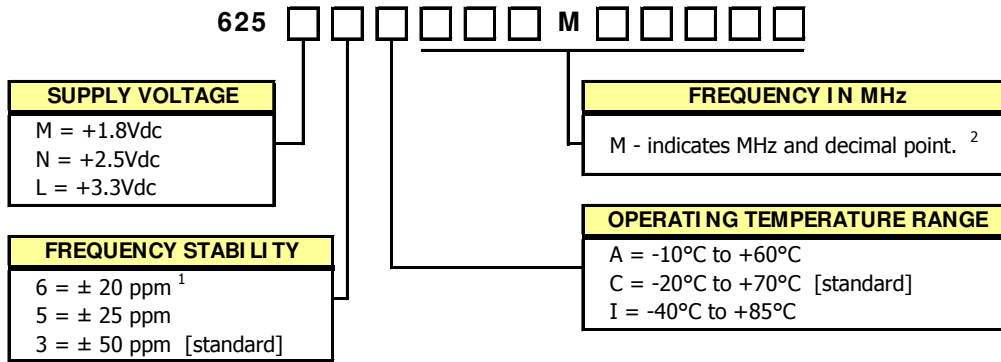

1] Consult factory for 6I Stability/Temperature availability.
 2] Frequency is recorded with three leading significant digits before the 'M' and 5 significant digits after the 'M' (including zeros).
 [Ex. 3.579545 MHz, code as 003M57954; 14.31818 MHz, code as 014M31818; 125 MHz, code as 125M00000]

**Not all performance combinations and frequencies may be available.
 Contact your local CTS Representative or CTS Customer Service for availability.**

PACKAGING INFORMATION [reference]

Device quantity is 1k pcs. minimum and 3k pcs. maximum per 180mm reel. **8mm tape width.**

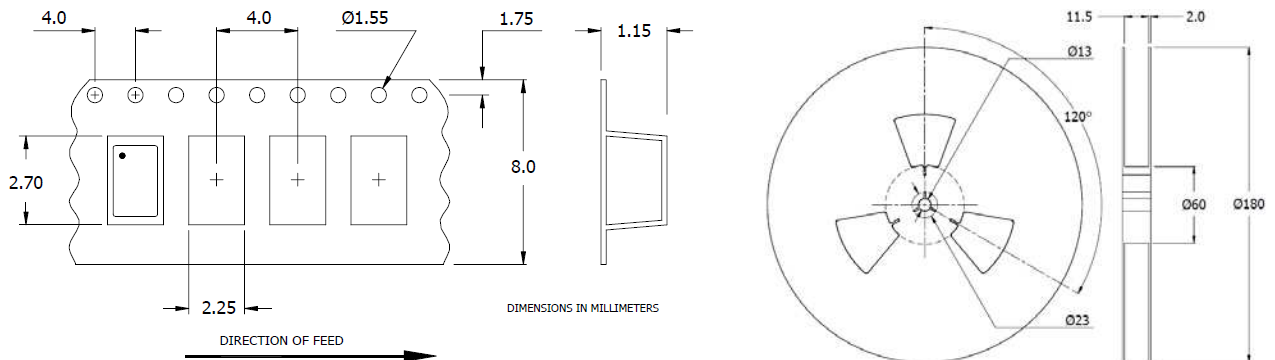

ELECTRICAL CHARACTERISTICS

PARAMETER	SYMBOL	CONDITIONS	MIN	TYP	MAX	UNIT
Maximum Supply Voltage	V_{CC}	-	-0.5	-	4.0	V
Storage Temperature	T_{STG}	-	-40	-	+100	°C
Frequency Range	f_o	-	1.0	-	110	MHz
Frequency Stability [See Note 1 and Ordering Information]	$\Delta f/f_o$	-	-	-	20, 25, 50	± ppm
Aging	$\Delta f/f_o$	@+25°C, 1st year	-	-	3	± ppm
Operating Temperature						
Commercial	T_A	-	-10	+25	+60	°C
Industrial			-20		+70	
Supply Voltage	V_{CC}	±10%	1.62		1.8	
Model 625M			2.25	2.5	2.75	
Model 625L			2.97	3.3	3.63	
Supply Current	I_{CC}	$C_L = 15pF$				mA
Model 625M		1.0 MHz to 50 MHz	-	-	7	
[+1.8V]		50.1 MHz to 110 MHz	-	-	15	
Model 625N		1.0 MHz to 50 MHz	-	-	10	
[+2.5V]		50.1 MHz to 110 MHz	-	-	15	
Model 625L	1.0 MHz to 50 MHz	-	-	15		
[+3.3V]	50.1 MHz to 110 MHz	-	-	20		
Output Load	C_L		-	-	15	pF
Output Voltage Levels						
Logic '1' Level	V_{OH}	CMOS Load	90% V_{CC}	-	-	V
Logic '0' Level	V_{OL}	CMOS Load	-	-	10% V_{CC}	
Output Current						
Logic '1' Level [M,N,L]	I_{OH}	$V_{OH} = 90\%V_{CC}$ (1.8V, 2.5, 3.3V)	-	-	-2, -4, -8	mA
Logic '0' Level [M,N,L]	I_{OL}	$V_{OL} = 10\%V_{CC}$ (1.8V, 2.5, 3.3V)	-	-	+2, +4, +8	
Output Duty Cycle	SYM	@ 50% Level	45	-	55	%
Rise and Fall Time		@ 10% - 90% Levels, $C_L = 15pF$				
Model 625M	T_R, T_F	1.0 MHz to 20 MHz	-	-	5	ns
[+1.8V]		20.1 MHz to 110 MHz	-	-	4	
Model 625N		1.0 MHz to 20 MHz	-	-	4	
[+2.5V]		20.1 MHz to 110 MHz	-	-	3	
Model 625L		1.0 MHz to 20 MHz	-	-	3	
[+3.3V]	20.1 MHz to 110 MHz	-	-	2		
Start Up Time	T_S	Application of V_{CC}	-	2	5	ms
Enable Function						
Enable Input Voltage	V_{IH}	Pin 1 Logic '1', Output Enabled	0.7* V_{CC}	-	-	V
Disable Input Voltage	V_{IL}	Pin 1 Logic '0', Output Disabled	-	-	0.3* V_{CC}	
Enable Time [M,N,L]	T_{PLZ}	Pin 1 Logic '1'	-	-	5	ms
Standby Current	I_{ST}	Pin 1 Logic '0', Output Disabled	-	-	15	µA
Period Jitter, pk-pk	pjpk-pk	-	-	-	40	ps
Period Jitter, RMS	pjrms	-	-	-	25	
Phase Jitter, RMS	tjrms	Bandwidth 12 kHz - 20 MHz	-	-	1	

Notes:

- Inclusive of initial tolerance at time of shipment, changes in supply voltage, load, temperature and aging.

LVC MOS OUTPUT WAVEFORM

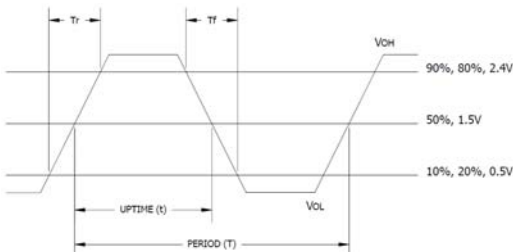

TEST CIRCUIT, CMOS LOAD

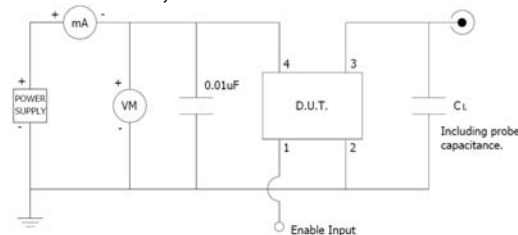

ENABLE TRUTH TABLE

PIN 1	PIN 3
Logic '1'	Output
Open	Output
Logic '0'	High Imp.

MECHANICAL SPECIFICATIONS

PACKAGE DRAWING

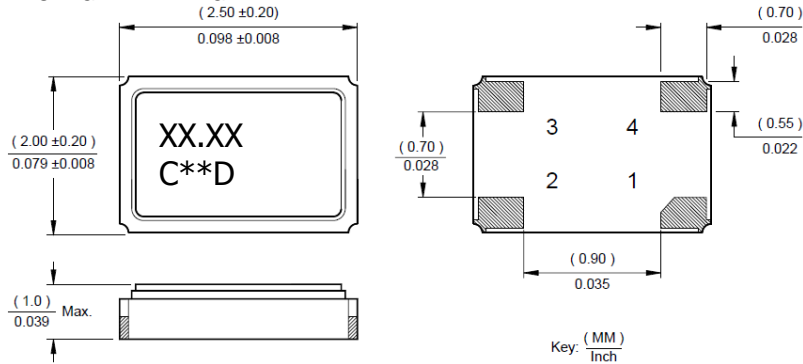

MARKING INFORMATION

1. XX.XX – Frequency in MHz.
2. C – CTS and Pin 1 identifier.
3. ** - Manufacturing Site Code.
4. D – Manufacturing Date Code.
[See Table 1 for codes.]
5. Complete CTS part number, frequency value and date code information must appear on reel and carton labels.

NOTES

1. Termination pads [e4]. Barrier-plating is nickel [Ni] with gold [Au] flash plate.
2. Reflow conditions per JEDEC J-STD-020; 260°C maximum, 20 seconds.
3. MSL = 1.

TABLE I

YEAR					MONTH											
					JAN	FEB	MAR	APR	MAY	JUN	JUL	AUG	SEP	OCT	NOV	DEC
2001	2005	2009	2013	2017	A	B	C	D	E	F	G	H	J	K	L	M
2002	2006	2010	2014	2018	N	P	Q	R	S	T	U	V	W	X	Y	Z
2003	2007	2011	2015	2019	a	b	c	d	e	f	g	h	j	k	l	m
2004	2008	2012	2016	2020	n	p	q	r	s	t	u	v	w	x	y	z

SUGGESTED SOLDER PAD GEOMETRY

C_{BYPASS} should be ≥ 0.01 uF.

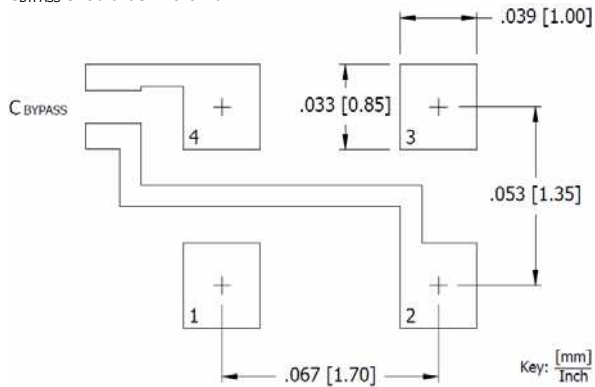

D.U.T. PIN ASSIGNMENTS

PIN	SYMBOL	DESCRIPTION
1	EOH	Enable
2	GND	Circuit & Package Ground
3	Output	RF Output
4	V _{CC}	Supply Voltage