



Chipsmall Limited consists of a professional team with an average of over 10 year of expertise in the distribution of electronic components. Based in Hongkong, we have already established firm and mutual-benefit business relationships with customers from,Europe,America and south Asia,supplying obsolete and hard-to-find components to meet their specific needs.

With the principle of "Quality Parts,Customers Priority,Honest Operation,and Considerate Service",our business mainly focus on the distribution of electronic components. Line cards we deal with include Microchip,ALPS,ROHM,Xilinx,Pulse,ON,Everlight and Freescale. Main products comprise IC,Modules,Potentiometer,IC Socket,Relay,Connector.Our parts cover such applications as commercial,industrial, and automotives areas.

We are looking forward to setting up business relationship with you and hope to provide you with the best service and solution. Let us make a better world for our industry!



Contact us

Tel: +86-755-8981 8866 Fax: +86-755-8427 6832

Email & Skype: info@chipsmall.com Web: www.chipsmall.com

Address: A1208, Overseas Decoration Building, #122 Zhenhua RD., Futian, Shenzhen, China



THIS DRAWING IS UNPUBLISHED. RELEASED FOR PUBLICATION, 19 .
 © COPYRIGHT 19 BY AMP INCORPORATED. ALL INTERNATIONAL RIGHTS RESERVED.

LOC	DIST	P	F	ZONE	LTR	DESCRIPTION	DATE	APPD
AF	50				N	REVISED PER AF-7503	8/16/91	MSF/NN

- 1 CONTINUOUS STRIP ON REELS WITH TERMINALS LOCATED ON 5.08 [.200] CENTERS.
- ② SLOT ACCEPTS A 0.36-0.45 mm DIA [#27-#25] AWG COPPER MAGNET WIRE ONLY (2 WIRES MAX).
- ③ WIRE BARREL ACCEPTS 0.12-0.40 mm² [#26-#22] AWG LEAD WIRE.
- ④ IDENTIFICATION NUMBER FOR MAGNET WIRE RANGE.

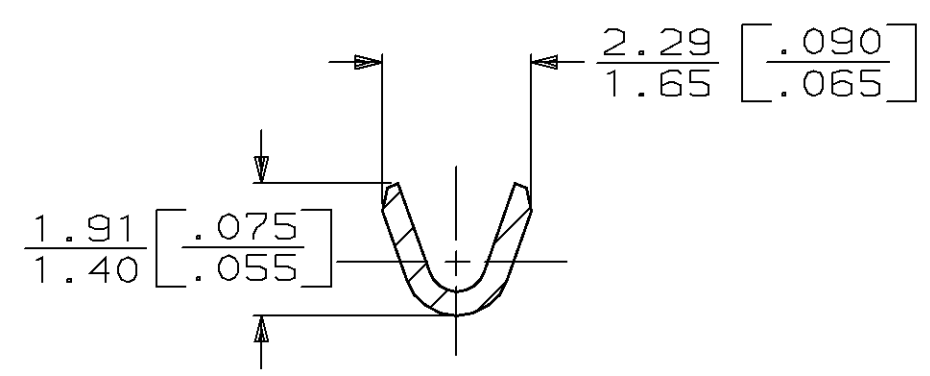
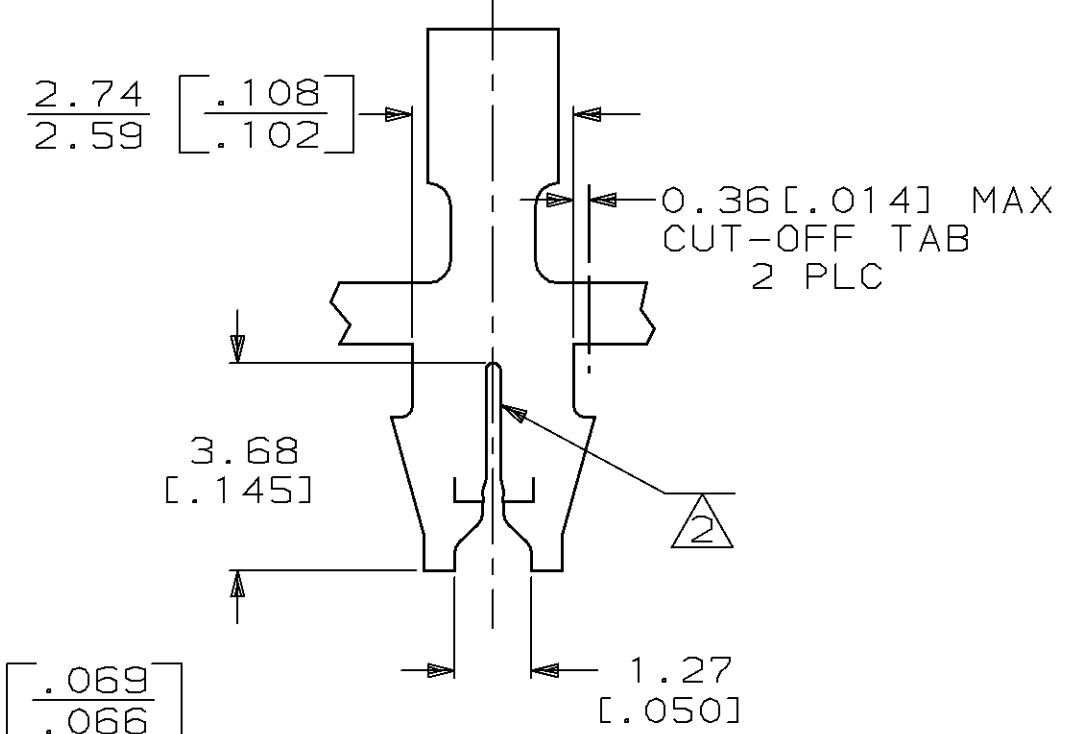
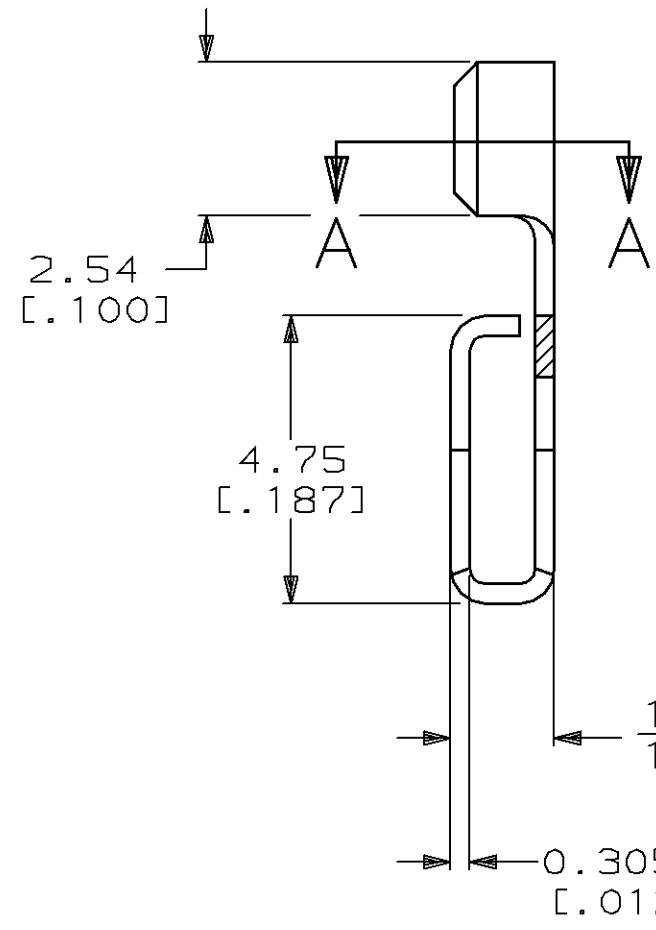
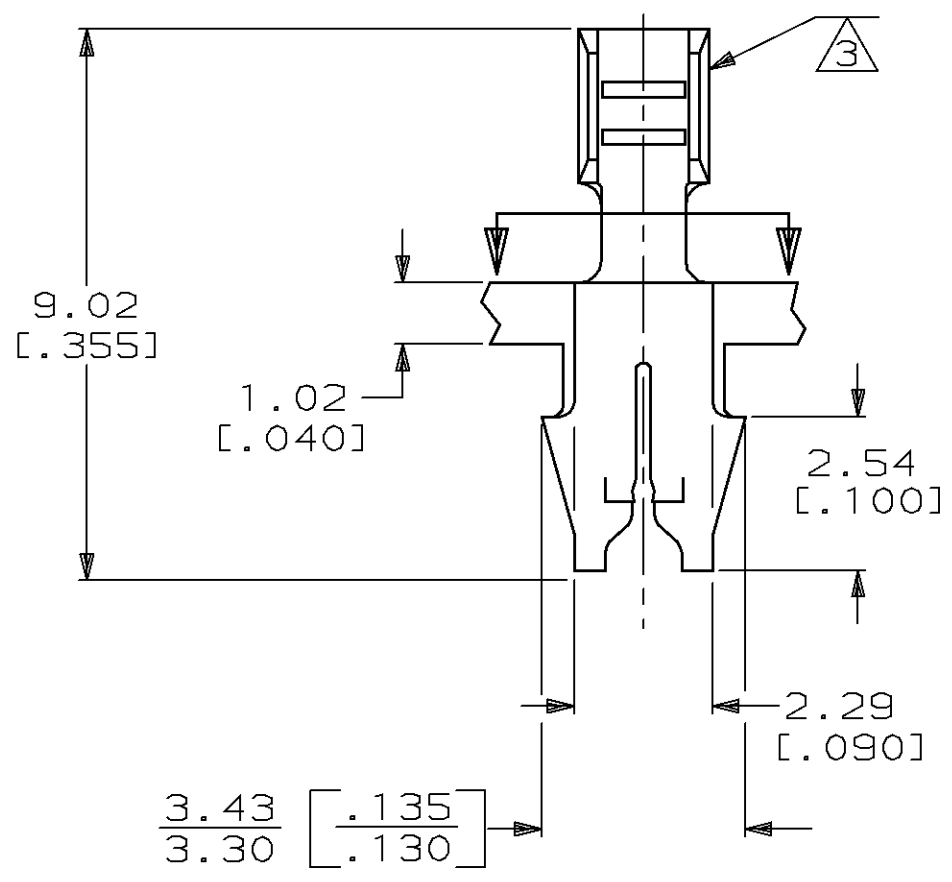
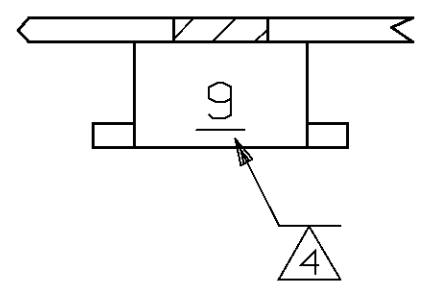

SECTION A-A
ROTATED 90° CW

OBSELETE	BENCH INSERTION MACHINE	0.00381 [.000150] MIN THK PER MIL-T-10727	62609-3
	REVERSE REEL OF 62609-1		62609-2
	MINI-APPLICATOR		62609-1
	REELING	FINISH	PART NO

DO NOT SCALE PRINT. UNLESS SPECIFIED DIMENSIONS IN mm [INCHES] TOLERANCES ON : 2 PLC DEC ± - 3 PLC DEC ± 0.38 [.015] ANGLES ± -	DR 8/3/89 DK SCHRUM CHK 8/16/89 MS FEHER APPD 8/16/89 NE NEFF APPD 8/17/89 TL SHUTTER	AMP INCORPORATED Harrisburg, Pa. 17105	
MATERIAL #4 HARD BRASS	PRODUCT SPEC -	NAME TERMINAL, F CRIMP, MAG-MATE™	
FINISH SEE TABLE	APPLICATION SPEC 114-2069	SIZE C	CAGE CODE 00779
	WEIGHT -	SCALE 8:1	DRAWING NO 62609
			SHEET 1 OF 1

3.56 [.140]	F	1.40 [.055]	0.97 [.038]	0.35 [.22]
			0.89 [.035]	0.20 [.24]
			0.86 [.034]	0.14 [.26]
STRIP LENGTH ±.015	TYPE	WIDTH	±0.051 [.002] HEIGHT	WIRE
WIRE BARREL CRIMP				

PROPOSED DESIGN
NOT RELEASED FOR
PRODUCTION

