

Chipsmall Limited consists of a professional team with an average of over 10 year of expertise in the distribution of electronic components. Based in Hongkong, we have already established firm and mutual-benefit business relationships with customers from,Europe,America and south Asia,supplying obsolete and hard-to-find components to meet their specific needs.

With the principle of “Quality Parts,Customers Priority,Honest Operation,and Considerate Service”,our business mainly focus on the distribution of electronic components. Line cards we deal with include Microchip,ALPS,ROHM,Xilinx,Pulse,ON,Everlight and Freescale. Main products comprise IC,Modules,Potentiometer,IC Socket,Relay,Connector.Our parts cover such applications as commercial,industrial, and automotives areas.

We are looking forward to setting up business relationship with you and hope to provide you with the best service and solution. Let us make a better world for our industry!



Contact us

Tel: +86-755-8981 8866 Fax: +86-755-8427 6832

Email & Skype: info@chipsmall.com Web: www.chipsmall.com

Address: A1208, Overseas Decoration Building, #122 Zhenhua RD., Futian, Shenzhen, China

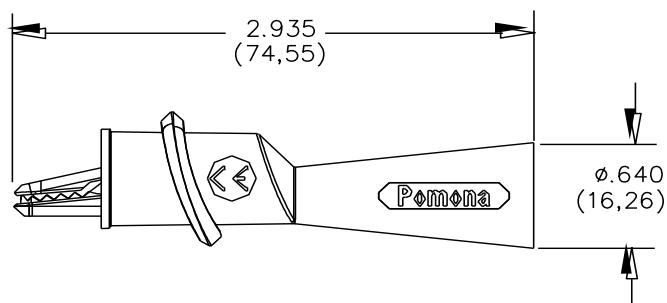
Model 6264B**Alligator Clip with Flex Boot for standard test probe tip, .080" (2mm)****Features**

- Redesigned to meet IEC 61010-031, the latest international safety standard for test accessories.
- Medium alligator jaw grips onto test terminal up to 0.3" (7.6mm) O.D.
- Thermoplastic body and flexible boot offers insulation protection.
- Alligator clip features a recessed 2mm pin tip jack at the adapter end for added insulation protection. The pin tip jack also features internal threads for added mating with the Pomona 6601 Test Probes.
- Adapter converts a .080" (2mm) DMM probe tip to alligator clips for ease of testing.
- Interfaces to Pomona's Models 5519A, 6365, 6366, 5898 and 6601 Test Probes.

Materials

Alligator Clip: Steel, nickel-plated
Jaw Insulation: Polypropylene
Boot: Santoprene™

Ratings

IEC 61010-031, Pollution Degree 2, 2000 m altitude
Voltage: 1000 V CAT II / 600 V CAT III
Temperature: -20°C to 55°C (-4°F to +131°F) 80% R.H.
Current: 10 amperes max.

Ordering Information

Model: 6264B (Set of one Black, one Red Alligator Clips)
Medium Alligator Clips are also included in many Pomona DMM Test Lead Kits.

USA: Sales: 800-490-2361
Technical Support: technicalsupport@pomonatest.com
Fax: 425-446-5844

Europe: 31-(0) 40 2675 150 **International:** 425-446-5500
Where to Buy: www.pomonaelectronics.com

All dimensions are in inches. Tolerances (except noted): .xx = ±.02" (.51 mm), .xxx = ±.005" (.127 mm). All specifications are to the latest revisions. Specifications are subject to change without notice. Registered trademarks are the property of their respective companies.