



Chipsmall Limited consists of a professional team with an average of over 10 year of expertise in the distribution of electronic components. Based in Hongkong, we have already established firm and mutual-benefit business relationships with customers from,Europe,America and south Asia,supplying obsolete and hard-to-find components to meet their specific needs.

With the principle of “Quality Parts,Customers Priority,Honest Operation,and Considerate Service”,our business mainly focus on the distribution of electronic components. Line cards we deal with include Microchip,ALPS,ROHM,Xilinx,Pulse,ON,Everlight and Freescale. Main products comprise IC,Modules,Potentiometer,IC Socket,Relay,Connector.Our parts cover such applications as commercial,industrial, and automotives areas.

We are looking forward to setting up business relationship with you and hope to provide you with the best service and solution. Let us make a better world for our industry!



Contact us

Tel: +86-755-8981 8866 Fax: +86-755-8427 6832

Email & Skype: info@chipsmall.com Web: www.chipsmall.com

Address: A1208, Overseas Decoration Building, #122 Zhenhua RD., Futian, Shenzhen, China



THIS DRAWING IS UNPUBLISHED. RELEASED FOR PUBLICATION
 BY AMP INCORPORATED. ALL RIGHTS RESERVED.

LOC		DIST		REVISIONS			
P	LTR	DESCRIPTION		DATE	DWN	APVD	
AF	50	0		DRAWN PER OL10-0505-97	08JAN98	MF	NN

- ① SLOT ACCEPTS 0.36-0.57mm [#27-#23] AWG COPPER MAGNET WIRE. A SINGLE WIRE ONLY.
- ② POKE-IN ACCEPTS A 0.50-0.90mm² [#20-#18] AWG SOLID OR FUSED STRANDED LEAD WIRE.
- ③ DIMENSION APPLIES WITH LEAF EDGE TOUCHING CARRIER SIDE OF BOX.
- ④ RED COLOR STRIPE APPLIED TO THIS SURFACE DURING LOOSE PIECE OPERATION TO PROVIDE COLOR CODING OF MAGNET WIRE RANGE.

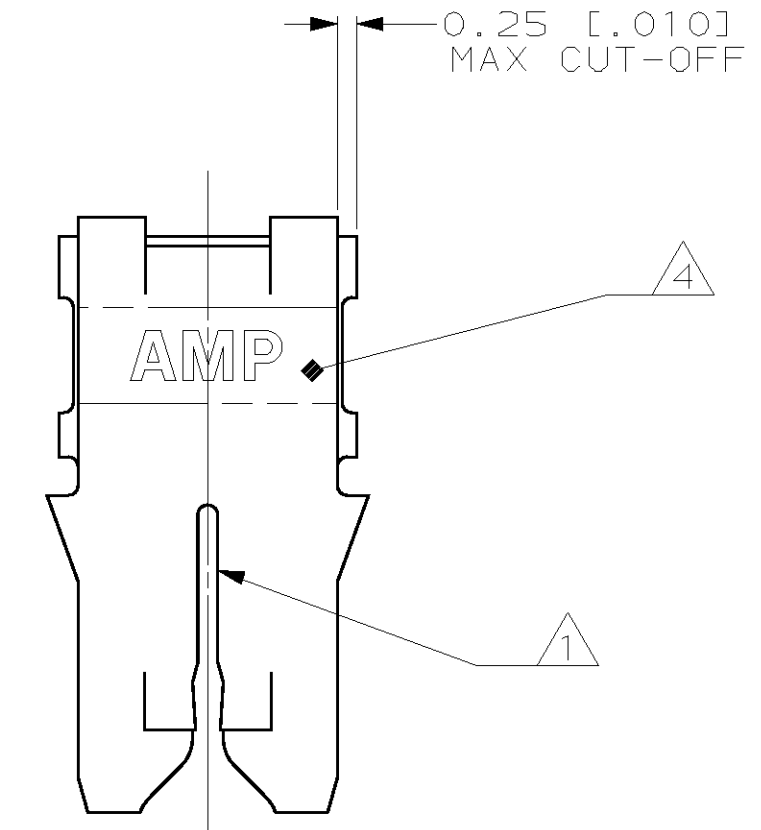
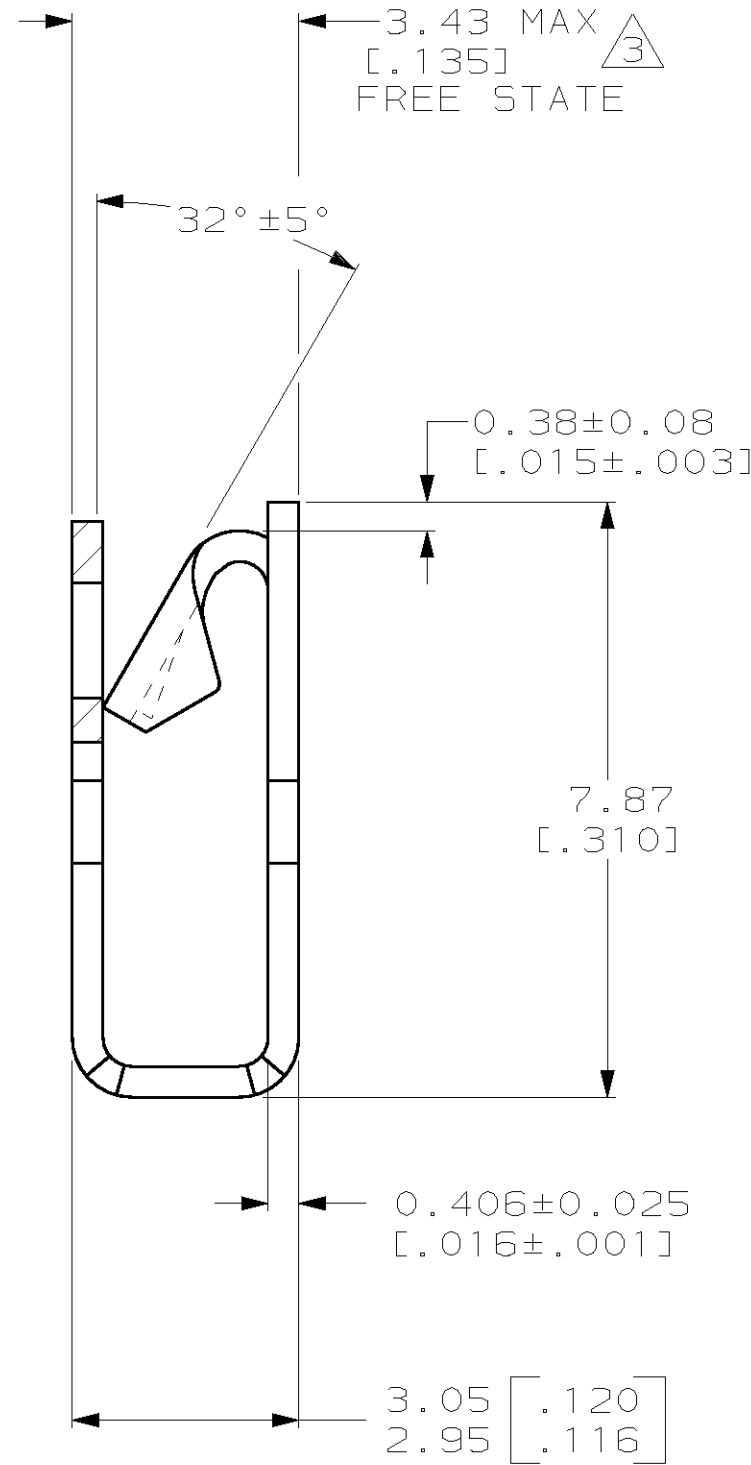
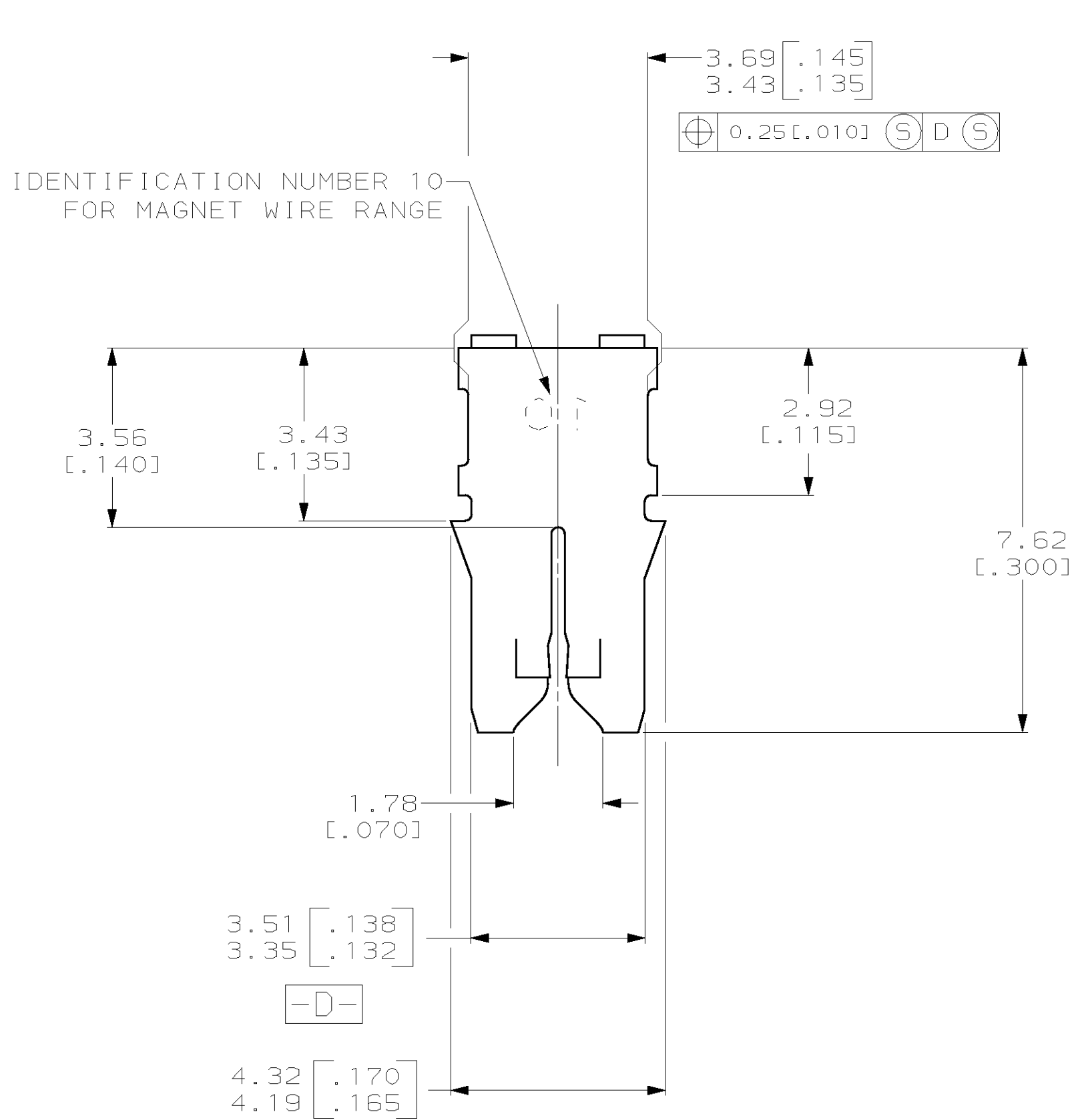
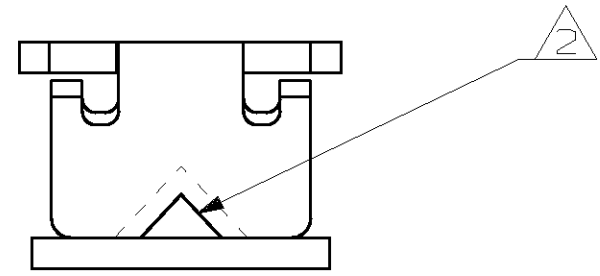

63044-1
PART NO.

THIS DRAWING IS A CONTROLLED DOCUMENT.		DWN MICHAEL S. FEHER 13NOV97	AMP Incorporated Harrisburg, PA 17105-3608	
DIMENSIONS: mm [INCHES]		CHK JEFF R. RUTH 09JAN98	NAME TERMINAL, POKE-IN, LOOSE PIECE, MAG-MATE™	
TOLERANCES UNLESS OTHERWISE SPECIFIED:		APVD NELSON E. NEFF 13JAN98	PRODUCT SPEC 108-2012	
0 PLC ±-		APPLICATION SPEC 114-2046		
1 PLC ±-		SIZE A2		
2 PLC ±0.25 [.010]		CAGE CODE 00779		
3 PLC ±-		DRAWING NO 63044		
4 PLC ±-		RESTRICTED TO -		
ANGLES ±-		SCALE 10:1		
MATERIAL 4M BRASS		SHEET 1 OF 1		
FINISH 0.002032 [.000080] MIN TIN PER MIL-T-10727		REV 0		
CUSTOMER DRAWING				