



Chipsmall Limited consists of a professional team with an average of over 10 year of expertise in the distribution of electronic components. Based in Hongkong, we have already established firm and mutual-benefit business relationships with customers from,Europe,America and south Asia,supplying obsolete and hard-to-find components to meet their specific needs.

With the principle of “Quality Parts,Customers Priority,Honest Operation,and Considerate Service”,our business mainly focus on the distribution of electronic components. Line cards we deal with include Microchip,ALPS,ROHM,Xilinx,Pulse,ON,Everlight and Freescale. Main products comprise IC,Modules,Potentiometer,IC Socket,Relay,Connector.Our parts cover such applications as commercial,industrial, and automotives areas.

We are looking forward to setting up business relationship with you and hope to provide you with the best service and solution. Let us make a better world for our industry!



## Contact us

Tel: +86-755-8981 8866 Fax: +86-755-8427 6832

Email & Skype: info@chipsmall.com Web: www.chipsmall.com

Address: A1208, Overseas Decoration Building, #122 Zhenhua RD., Futian, Shenzhen, China



## Model 6344 Basic Electronic Test Lead Kit

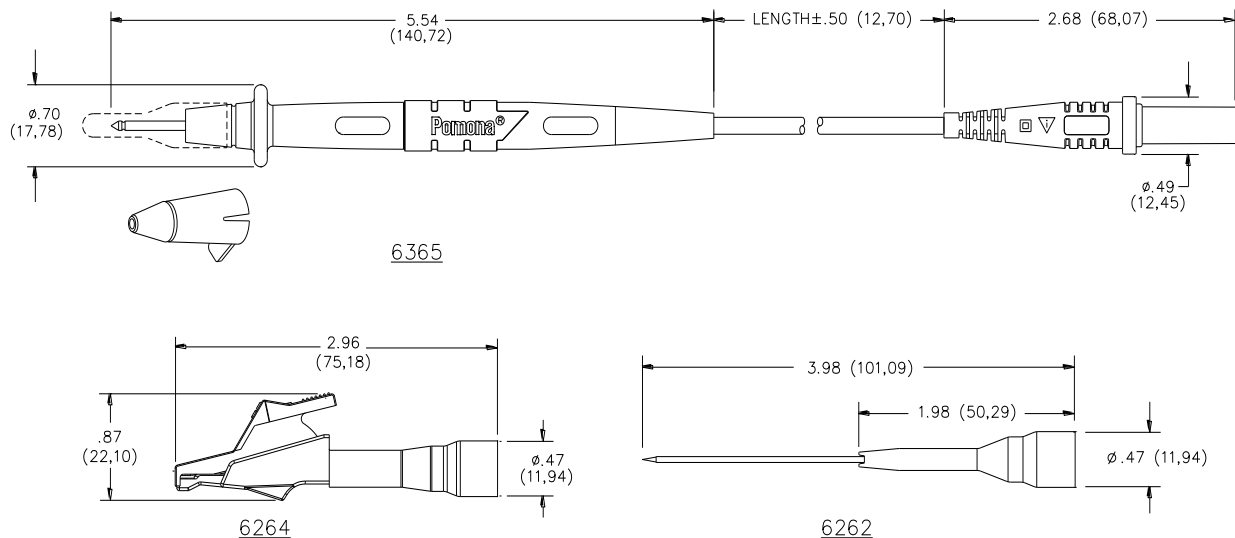

### FEATURES:

- Test accessories comply with IEC 61010-031 requirements
- Extended slide on tip adapter fits directly over probe, allowing testing of hard to reach test points
- Wear indication with double insulated (dual extruded) silicone leads shows white inner layer for increased safety
- Compatible with most Fluke, Amprobe, H.P., Tektronic & Wavetek digital multimeters

### MATERIALS:

Model **6365**: Probe Body: Outer Insulation – Santoprene® Rubber, Color: Gray, Inner Insulation – Polypropylene Fire Retardant, Color: One Black, One Red, Tip: Brass, Wire: 18 AWG, 192 x 41 bare copper, Silicone Insulation, O.D. 0.144" (3,66mm), Length: 48" (122cm)

Banana Plug: Body – Brass, Nickel Plated, Spring – Beryllium Copper, Nickel Plated, Insulation – Polypropylene, Color: One Black, One Red, **RATINGS**: IEC 61010-031, CAT III, 1000 V (with protective cap), CAT II 1000 V (without protective cap). Current: 10 Amperes

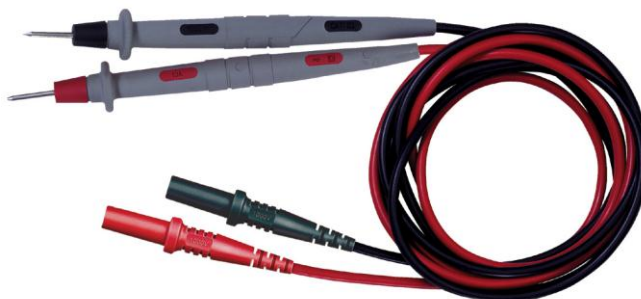

Model **6264**: Body – Steel, Nickel Plated, Insulation – Polypropylene fire retardant, Spring: Music Wire, **RATINGS**: IEC 61010-031, Category III, Operating Voltage: 300 V, Current: 3 Amperes.

Model **6262**: Tip: Stainless Steel, Tip Insulation: Kynar, Body: Polypropylene fire retardant, **RATINGS**: IEC 61010-031, Category II, Operating Voltage: 300 V, Current: 3 Amperes.

### ORDERING INFORMATION: 6344 (Includes a kit of items from above)

Replacement P/N's:

- Model **6264**: Probe Adapter Alligator Tip
- Model **6262**: Probe Adapter Extended Fine Tip
- Model **6365**: Probe to Straight DMM Plug

**USA:** Sales: 800-490-2361  
Technical Support: [technicalsupport@pomonatest.com](mailto:technicalsupport@pomonatest.com)  
Fax: 425-446-5844

**Europe:** 31-(0) 40 2675 150 **International:** 425-446-5500  
**Where to Buy:** [www.pomonaelectronics.com](http://www.pomonaelectronics.com)

All dimensions are in inches. Tolerances (except noted): .xx = ±.02" (.51 mm), .xxx = ±.005" (.127 mm). All specifications are to the latest revisions. Specifications are subject to change without notice. Registered trademarks are the property of their respective companies.