



Chipsmall Limited consists of a professional team with an average of over 10 year of expertise in the distribution of electronic components. Based in Hongkong, we have already established firm and mutual-benefit business relationships with customers from,Europe,America and south Asia,supplying obsolete and hard-to-find components to meet their specific needs.

With the principle of “Quality Parts,Customers Priority,Honest Operation,and Considerate Service”,our business mainly focus on the distribution of electronic components. Line cards we deal with include Microchip,ALPS,ROHM,Xilinx,Pulse,ON,Everlight and Freescale. Main products comprise IC,Modules,Potentiometer,IC Socket,Relay,Connector.Our parts cover such applications as commercial,industrial, and automotives areas.

We are looking forward to setting up business relationship with you and hope to provide you with the best service and solution. Let us make a better world for our industry!



Contact us

Tel: +86-755-8981 8866 Fax: +86-755-8427 6832

Email & Skype: info@chipsmall.com Web: www.chipsmall.com

Address: A1208, Overseas Decoration Building, #122 Zhenhua RD., Futian, Shenzhen, China



LOC	DIST	REVISIONS			
P	LTR	DESCRIPTION	DATE	DWN	APVD
AF	50				
	K	REVISED PER ECR-06-010427	01SEP06	HMR	KR

IDENTIFICATION NUMBER 24 FOR MAGNET WIRE RANGE

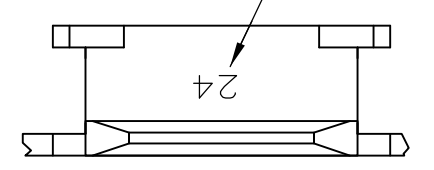

- 1 SLOT ACCEPTS 0.91-1.15mm [#19-#17] AWG COPPER MAGNET WIRE. 2 WIRES OF THE SAME SIZE MAX PER SLOT.
- 2 AFTER INSERTION INTO PLASTIC HOLDER TAB PORTION MUST BE BENT OVER 45° TO 90° OR POTTED-IN TO PREVENT PULL-OUT WHEN MATING RECEPTACLE IS DISCONNECTED.
- 3 CONTINUOUS STRIP ON REELS WITH TERMINALS LOCATED ON 8.38±0.08 [.330±.003] CENTERS.
- 4 VARNISH RESIST OVER 0.002032 [.000080] MIN TIN PER MIL-T-10727

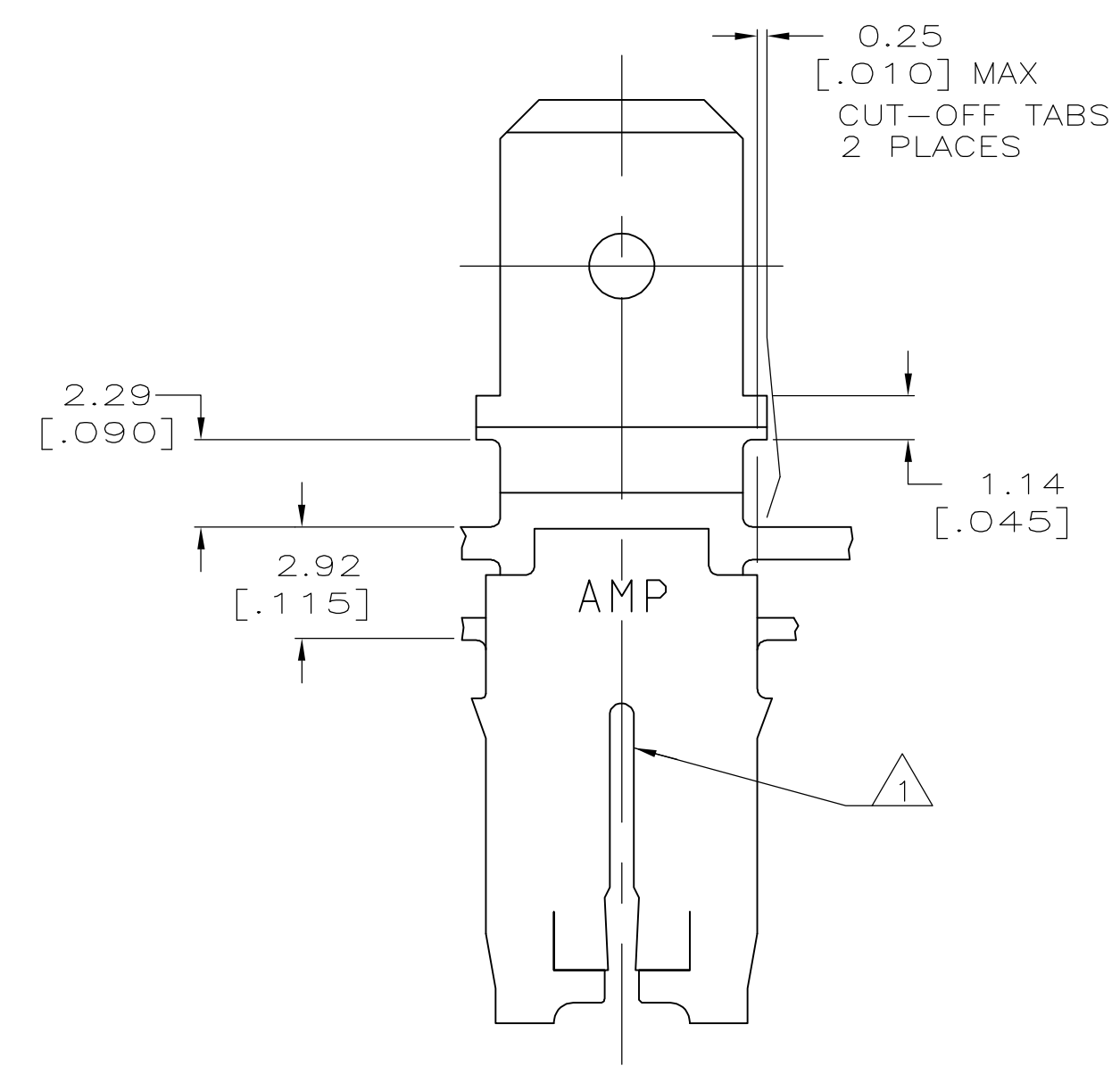
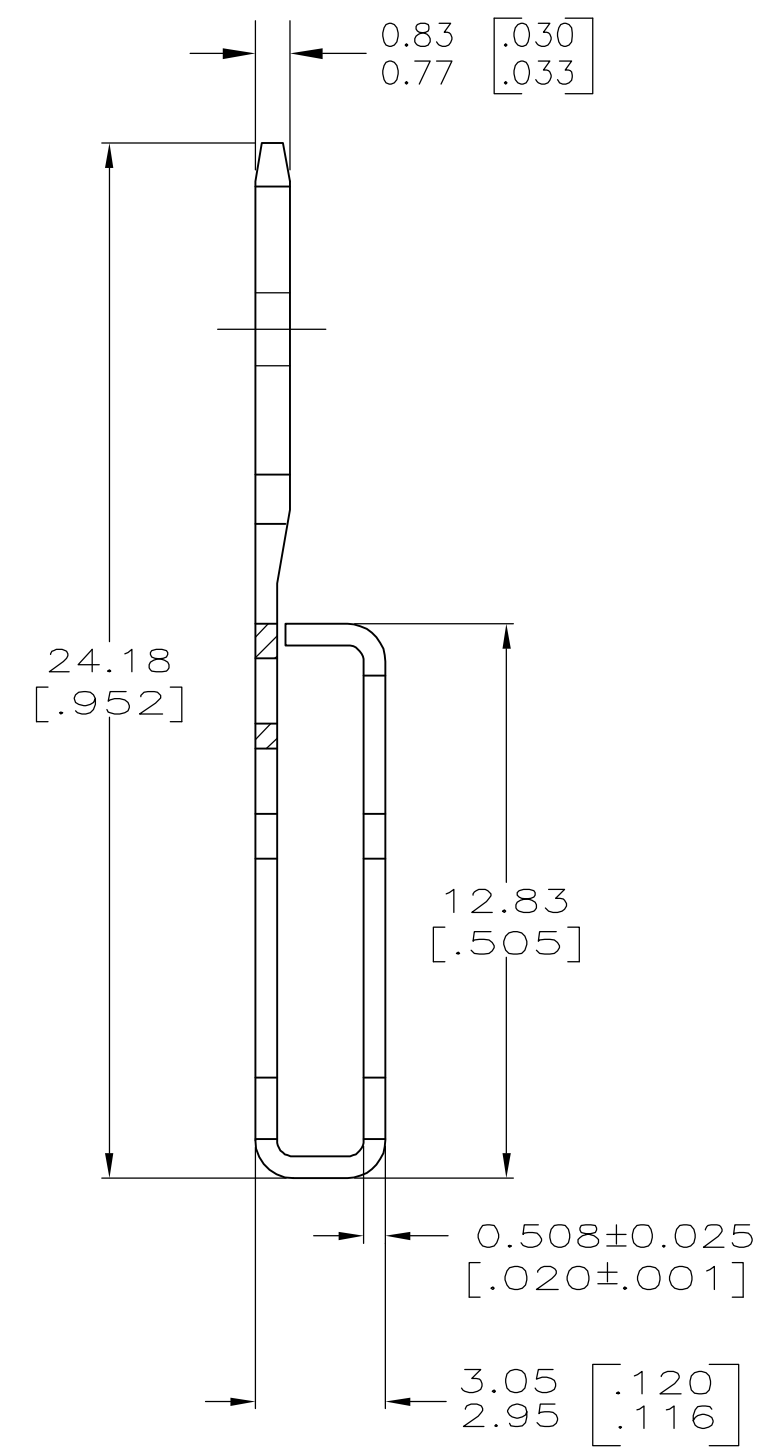
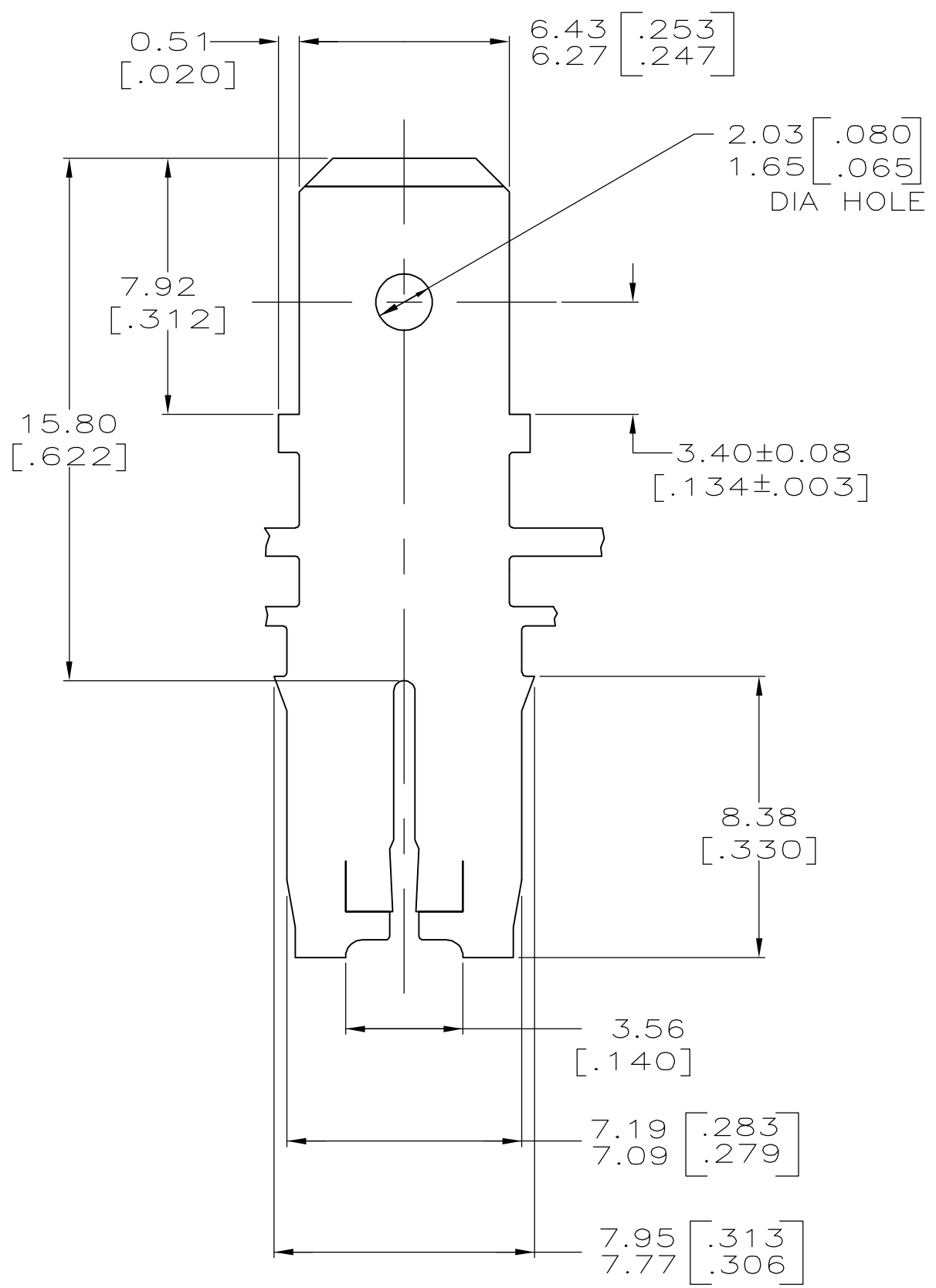

OBSOLETE	SPECIAL	4	63464-4
	STANDARD	4	63464-3
PART NO			

THIS DRAWING IS A CONTROLLED DOCUMENT.		DWN 24/OCT/94 PHILLIP M. FORTNEY		Tyco Electronics Corporation Harrisburg, PA 17105-3608	
DIMENSIONS: mm [INCHES]		CHK 25/OCT/94 MICHAEL S. FEHER		NAME TAB, 6.35 [.250] FASTON, [™] MAG-MATE [™]	
TOLERANCES UNLESS OTHERWISE SPECIFIED:		APVD 25/OCT/94 NELSON E. NEFF	PRODUCT SPEC 108-2053		RESTRICTED TO
0 PLC ± -		APPLICATION SPEC 114-2066		SIZE	DRAWING NO 00779
1 PLC ± -		WEIGHT		CAGE CODE	
2 PLC ± 0.25 [.010]		MATERIAL 4M PRE-MILLED BRASS		DRAWING NO 63464	REV K
3 PLC ± -		FINISH SEE TABLE		SCALE	SHEET 1 of 1
4 PLC ± -		CUSTOMER DRAWING		6:1	
ANGLES ± -					