



Chipsmall Limited consists of a professional team with an average of over 10 year of expertise in the distribution of electronic components. Based in Hongkong, we have already established firm and mutual-benefit business relationships with customers from,Europe,America and south Asia,supplying obsolete and hard-to-find components to meet their specific needs.

With the principle of “Quality Parts,Customers Priority,Honest Operation,and Considerate Service”,our business mainly focus on the distribution of electronic components. Line cards we deal with include Microchip,ALPS,ROHM,Xilinx,Pulse,ON,Everlight and Freescale. Main products comprise IC,Modules,Potentiometer,IC Socket,Relay,Connector.Our parts cover such applications as commercial,industrial, and automotives areas.

We are looking forward to setting up business relationship with you and hope to provide you with the best service and solution. Let us make a better world for our industry!



Contact us

Tel: +86-755-8981 8866 Fax: +86-755-8427 6832

Email & Skype: info@chipsmall.com Web: www.chipsmall.com

Address: A1208, Overseas Decoration Building, #122 Zhenhua RD., Futian, Shenzhen, China



Model 6358 Test Lead, Straight DMM Plug To Retractable Plug

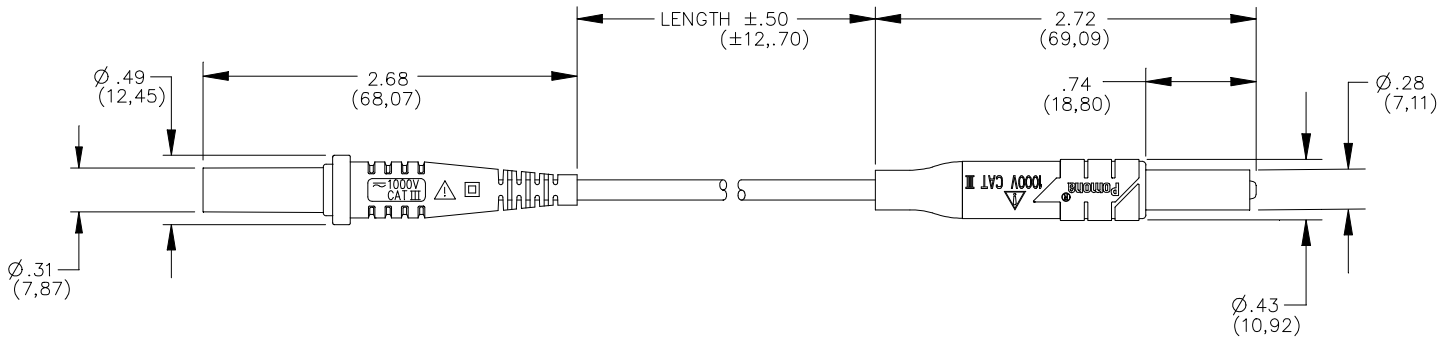

FEATURES:

- Fits Fluke, Amprobe, H-P, Tektronix, Wavetek and Amprobe DMM's with sheathed style safety jacks.
- Flexible test leads feature high strand count silicone wire for extreme flexibility and high temperature resistance. Banana plugs are double crimped to the wire and the plugs are molded directly to the wire for added pull strength.
- The retractable sheath is ideal for connecting to older test equipment without double insulated jacks.

MATERIALS:

Test Leads (Male to Male) – Multi-Stranded Wire: 18 AWG Silicone, Color: One Black, One Red

Banana Plug: Insulation: Polypropylene, Color: One Black, One Red

Retractable Sheath Banana Plug:

Plug Body: Brass, Nickel Plated

Banana Spring: Beryllium Copper, Nickel Plated

Compression Spring: Stainless Steel

Tip: Polypropylene, Color Matches Color of Wire

Insulation: Polypropylene Molded to the Plug and Wire. Color Matches Color of Wire.

Wire: 18 AWG, Stranding 65 x 36 t.c., Silicone Insulated, .144 (3,66mm) O.D.

RATINGS:

Operating Temperature: +55° C (+131° F) Max.

Conforms to IEC 1010, Cat. III, P2

Operating Voltage: 1000V

Current: 10 Amperes

ORDERING INFORMATION: Model 6358

USA: Sales: 800-490-2361

Technical Support: technicalsupport@pomonatest.com

Fax: 425-446-5844

Europe: 31-(0) 40 2675 150 International: 425-446-5500

All dimensions are in inches. Tolerances (except noted): .xx = ±.02" (.51 mm), .xxx = ±.005" (.127 mm). All specifications are to the latest revisions. Specifications are subject to change without notice. Registered trademarks are the property of their respective companies.