



Chipsmall Limited consists of a professional team with an average of over 10 year of expertise in the distribution of electronic components. Based in Hongkong, we have already established firm and mutual-benefit business relationships with customers from,Europe,America and south Asia,supplying obsolete and hard-to-find components to meet their specific needs.

With the principle of “Quality Parts,Customers Priority,Honest Operation,and Considerate Service”,our business mainly focus on the distribution of electronic components. Line cards we deal with include Microchip,ALPS,ROHM,Xilinx,Pulse,ON,Everlight and Freescale. Main products comprise IC,Modules,Potentiometer,IC Socket,Relay,Connector.Our parts cover such applications as commercial,industrial, and automotives areas.

We are looking forward to setting up business relationship with you and hope to provide you with the best service and solution. Let us make a better world for our industry!



Contact us

Tel: +86-755-8981 8866 Fax: +86-755-8427 6832

Email & Skype: info@chipsmall.com Web: www.chipsmall.com

Address: A1208, Overseas Decoration Building, #122 Zhenhua RD., Futian, Shenzhen, China



THIS DRAWING IS UNPUBLISHED. RELEASED FOR PUBLICATION
 © COPYRIGHT BY TYCO ELECTRONICS CORPORATION. ALL RIGHTS RESERVED.

LOC		DIST		REVISIONS			
P	LTR	DESCRIPTION		DATE	DWN	APVD	
AF	50	E	REVISED PER ECR-06-010412	09NOV06	HMR	KR	

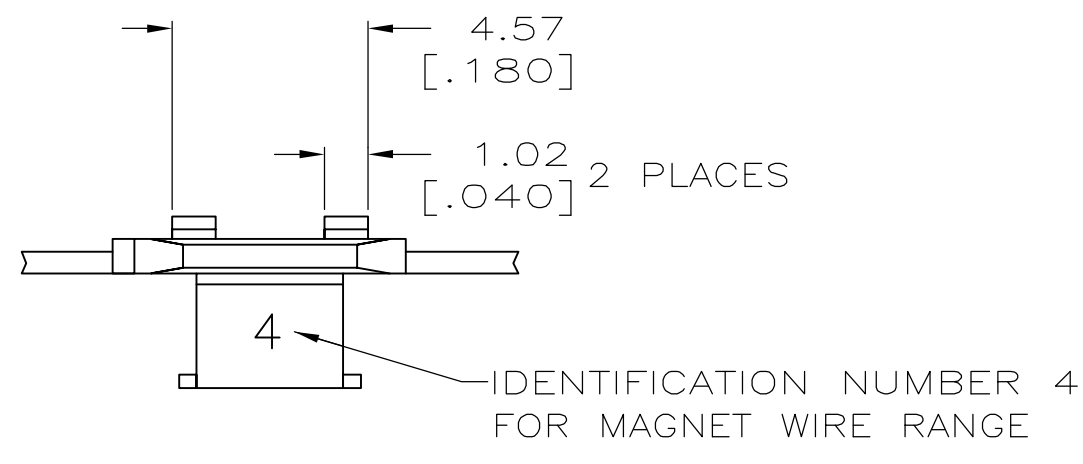

- 1 CONTINUOUS STRIP ON REELS WITH TERMINALS LOCATED ON 8.38±0.08 [.330±.003] CENTERS
- 2 SLOT ACCEPTS 0.18-0.23mm [#33-#31] AWG COPPER MAGNET WIRE. 2 WIRES OF THE SAME SIZE MAX PER SLOT.

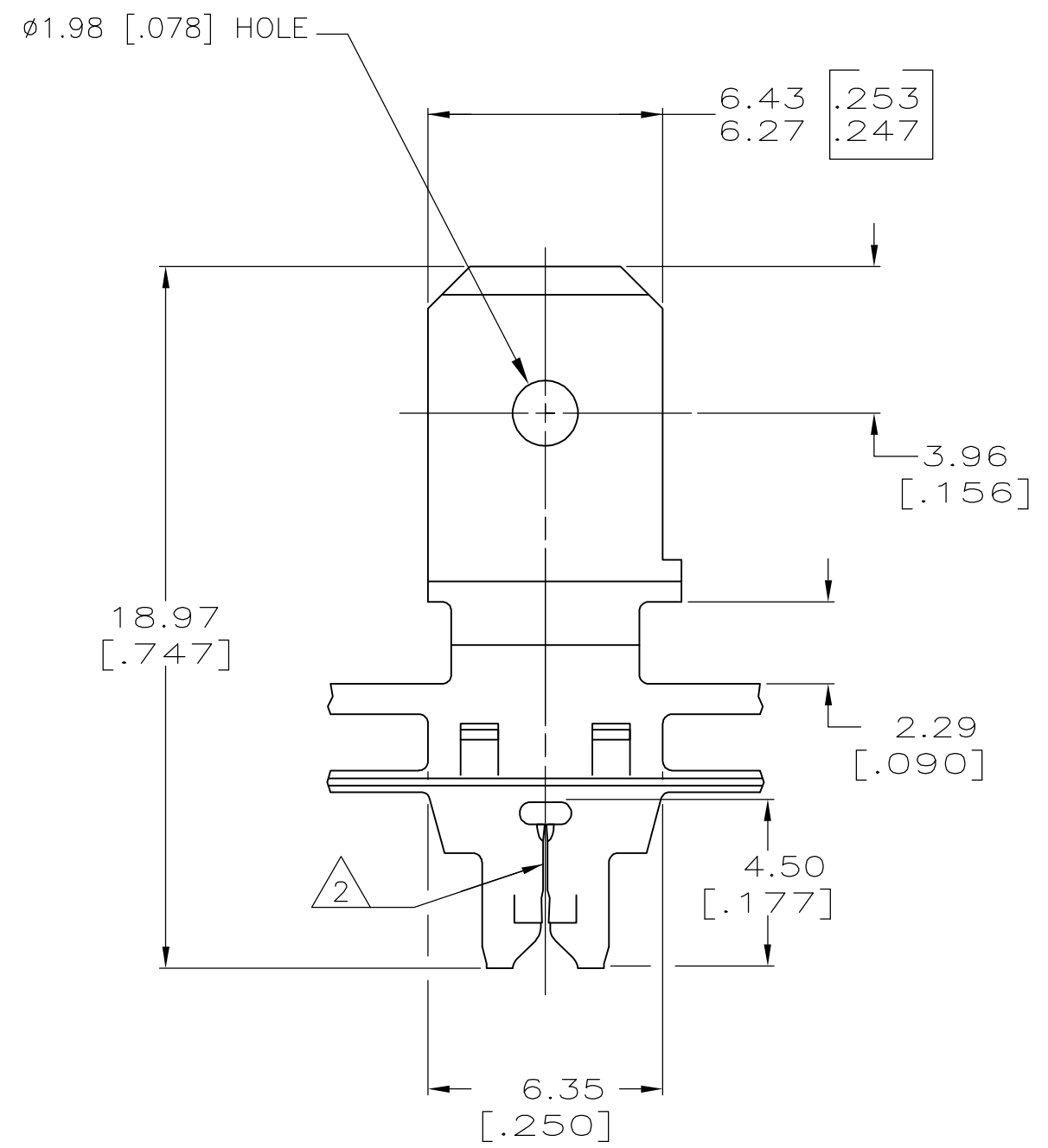
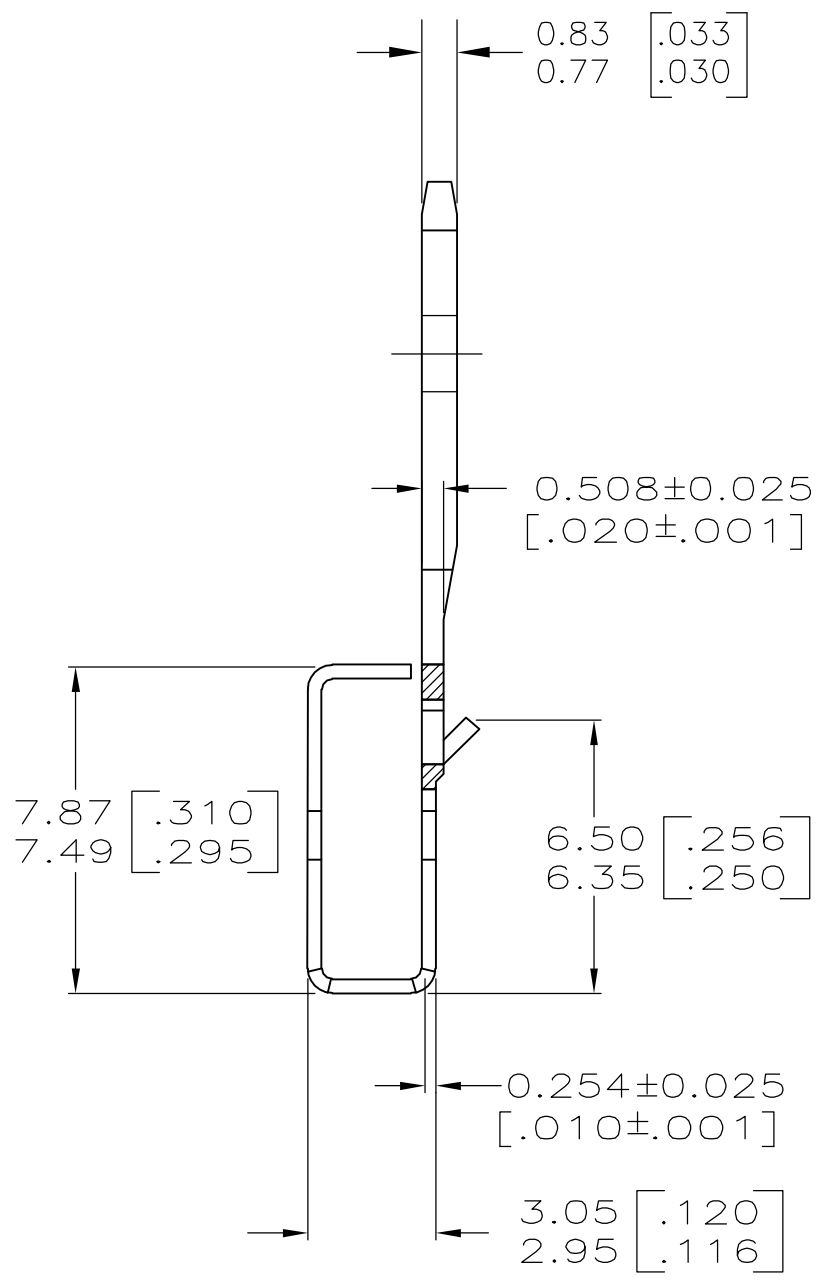
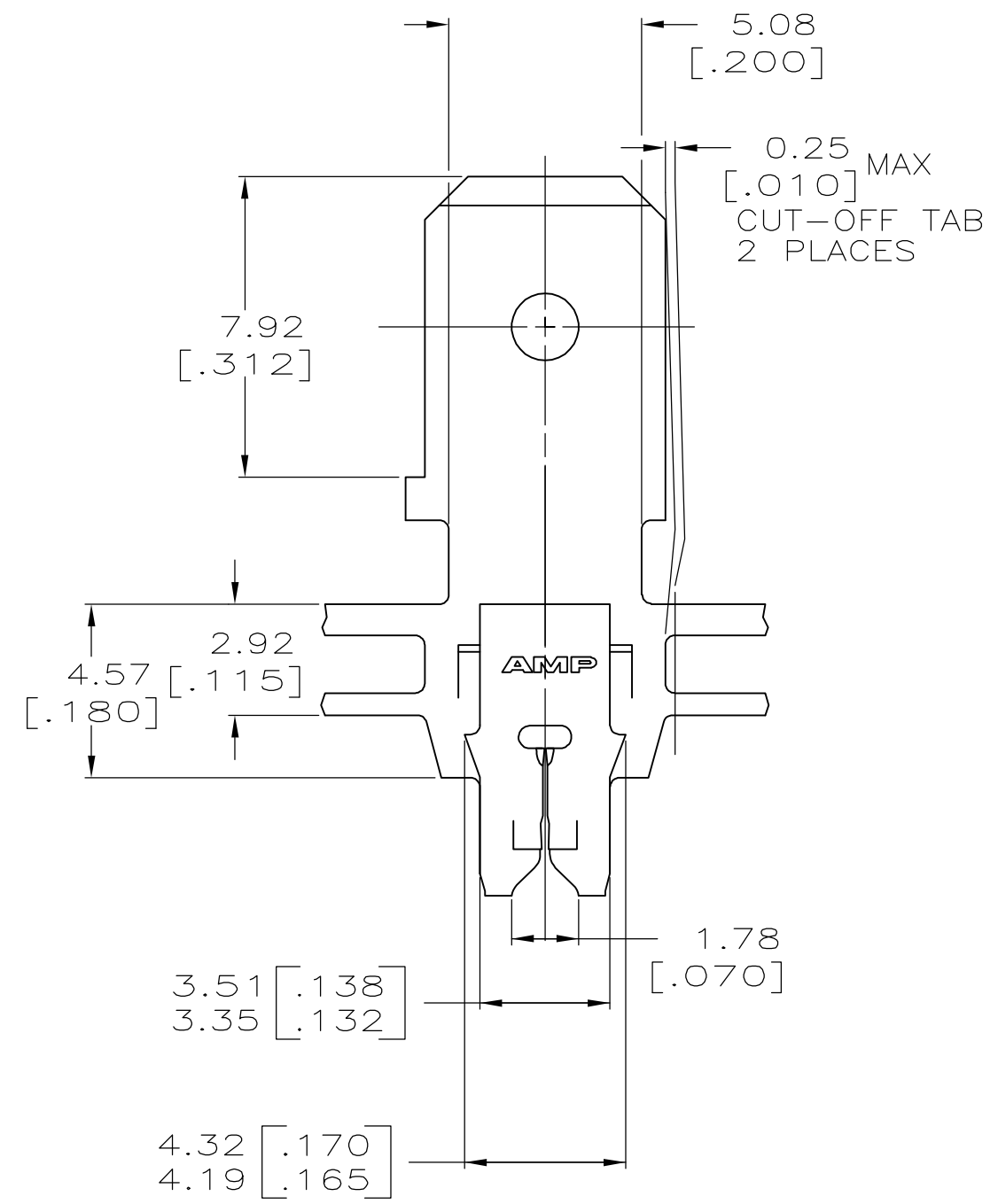

63618
 63618-1
 PART NUMBER

THIS DRAWING IS A CONTROLLED DOCUMENT.		DWN MICHAEL S. FEHER SR. 12/5/91	Tyco Electronics Corporation Harrisburg, PA 17105-3608	
DIMENSIONS: mm [INCHES]		CHK JEFF R. RUTH 12/9/91	APVD -	
TOLERANCES UNLESS OTHERWISE SPECIFIED:		NAME TAB, 6.35 [.250] FASTON, MAG-MATE		
0 PLC ± -		PRODUCT SPEC 108-2012		
1 PLC ± -		APPLICATION SPEC 114-2094		
2 PLC ± 0.25 [.010]		SIZE A2		
3 PLC ± -		CAGE CODE 00779		
4 PLC ± -		DRAWING NO G-63618		
ANGLES ± -		RESTRICTED TO -		
MATERIAL 4M PRE-MILLED BRASS	FINISH 0.002032 [.000080] MIN TIN	WEIGHT -		
CUSTOMER DRAWING		SCALE 6:1 SHEET 1 OF 1 REV E		